

## Introduction

### Purpose of this Manual

This manual provides instructions for installing Speaker Retrofit Kit M01491K001 in Encore™ series units.

### Required Reading

Before installing the equipment, the installer must read, understand, and follow:

- this manual
- NFPA 30A, The Automotive and Marine Service Station Code
- NFPA 70, The National Electric Code
- applicable federal, state and local codes and regulations

Failure to do so may adversely affect the safe use and operation of the equipment.

*Note: This kit must be installed by a Gilbarco ASC (Authorized Service Contractor) to insure warranty.*

### Related Documents

<b>Document Number</b>	<b>Document Title</b>	<b>GOLD<sup>SM</sup> Library</b>
MDE-3804	Encore and Eclipse™ Start-up/Service Manual	Encore and Eclipse
MDE-3893	Encore / Eclipse Series Owner's Manual	Encore and Eclipse
MDE-3985	Encore Installation Manual	Encore and Eclipse
PT-1936	Encore Illustrated Parts Manual	Encore and Eclipse

### Required Tools

**The following equipment is needed to install the speaker kit:**

- ratchet set, standard
- screwdrivers, flat and Phillips head

### Required Parts

**Kit M01491K001 contains the following parts:**

<b>Description</b>	<b>Part Number</b>	<b>Quantity</b>
Speaker Assembly	M01124A001	1
Screw, Self tapping 6-20 X .38	Q11677-24	3

## Important Safety Information

This section introduces the hazards and safety precautions associated with installing, inspecting, maintaining or servicing this product. Before performing any task on this product, read this safety information and the applicable sections in this manual, where additional hazards and safety precautions for your task will be found. Fire, explosion, electrical shock or pressure release could occur and cause death or serious injury if these safe service procedures are not followed.

### Preliminary Precautions

You are working in a potentially dangerous environment of flammable fuels, vapors, and high voltage or pressures. Only trained or authorized individuals knowledgeable in the related procedures should install, inspect, maintain or service this equipment.

The first and most important information you must know is how to stop all fuel flow to the pump and island.

### Emergency Total Electrical Shut-Off

Locate the switch or circuit breakers that shut-off all power to all fueling equipment, dispensing devices, and submerged turbine pumps (STPs). These you must operate in the event of an emergency.

** WARNING**

The EMERGENCY STOP, ALL STOP, and PUMP STOP buttons at the cashier's station WILL NOT shut off electrical power to the pump/dispenser.

 This means that even if you activate these stops, fuel may continue to flow uncontrolled.

You must use the TOTAL ELECTRICAL SHUT-OFF in the case of an emergency and not only these cashier station "stops."



### Total Electrical Shut-Off Before Access

Any procedure requiring access to electrical components or the electronics of the dispenser requires total electrical shut-off of that unit.

NFPA 30A, Section 4-1.2, published by the National Fire Protection Association, requires the installation of an easily accessible switch or circuit breaker to shut-off the power to all fueling equipment, dispensing devices and STPs in the event of an emergency. Know the function and location of this switch or circuit breaker before inspecting, installing, maintaining, or servicing Gilbarco equipment.

## Evacuation, Barricading and Shut-Off

Any procedures requiring accessing the pump/dispenser or STPs requires the following three actions:

-  An evacuation of all unauthorized persons and vehicles
-  Using safety tape or cones as barricades to the effected units
-  A total electrical shut-off of that unit

## Read the Manual

Read, understand and follow this manual and any other labels or related materials supplied with this equipment. If you do not understand a procedure, call a Gilbarco Authorized Service Contractor or call the Gilbarco Call Center at 1-800-800-7498. It is imperative to your safety and the safety of others to understand the procedures before beginning work.

## Follow the Regulations

There is applicable information in: NFPA 30A: *Automotive and Marine Service Code*; NFPA 70: *National Electrical Code (NEC)*; OSHA regulations; and federal, state, and local codes which must be followed. Failure to install, inspect, maintain or service this equipment in accordance with these codes, regulations and standards may lead to legal citations with penalties or affect the safe use and operation of the equipment.

## Safety Symbols and Warning Words

This section provides important information about warning symbols and boxes.

### Alert Symbol



This safety alert symbol is used in this manual and on warning labels to alert you to a precaution which must be followed to prevent potential personal safety hazards. Obey safety directives that follow this symbol to avoid possible injury or death.

### Signal Words

These signal words used in this manual and on warning labels tell you the seriousness of particular safety hazards. The precautions that follow must be followed to prevent death, injury or damage to the equipment.

#### **DANGER**

This signal word is used to alert you to a hazard or unsafe practice which **will** result in **death or serious injury**.

#### **WARNING**

This alerts you to a hazard or unsafe practice that **could** result in **death or serious injury**.

#### **CAUTION**

This signal word designates a hazard or unsafe practice which **may** result in **minor injury**.

#### **CAUTION**

When used by itself, CAUTION designates a hazard or unsafe practice which may result in **property or equipment damage**.

## Prevent Explosions and Fires

Fuels and their vapors will become explosive if ignited. Spilled or leaking fuels cause vapors. Even filling customer tanks will cause explosive vapors in the vicinity of dispenser or island.

### No Open Flames



Open flames from matches, lighters, welding torches or other sources can ignite fuels and their vapors.

### No Sparks - No Smoking





Sparks from starting vehicles, starting or using power tools, burning cigarettes, cigars or pipes can also ignite fuels and their vapors. Static electricity, including an electrostatic charge on your body, can cause a spark sufficient to ignite fuels and their vapors. After getting out of a vehicle, touch the metal of your vehicle to discharge any electrostatic charge before you approach the dispenser island.

## Prevent Electrical Shock and Sparks

Dispensing devices use high voltage. A potential shock hazard exists when working on or around a dispensing device.

Follow OSHA lock-out and tag-out procedures.

Always turn OFF power to the dispensing device and associated submerged turbine pumps (STPs) when servicing or making electrical wiring connections. Multiple disconnects may be required.

 <b>WARNING</b>	
	<p>The EMERGENCY STOP, ALL STOP, and PUMP STOP buttons at the cashier's station WILL NOT shut off electrical power to the pump/dispenser.</p> <p>This means that even if you activate these stops, fuel may continue to flow uncontrolled.</p> <p>You must use the TOTAL ELECTRICAL SHUT-OFF in the case of an emergency and not only these cashier station "stops."</p>

### Close Junction Boxes Tightly

Spilled or leaking fuels in the vicinity of electrical junction boxes can be hazardous if boxes are not properly closed. Replace all bolts and tighten junction box cover before turning on AC power. Do not use gaskets on junction box covers.

### Field Wiring

Poorly wired pumps or dispensers could cause a fire, explosion or electrical shock. Place all power and lighting wires in threaded, rigid metal conduits. Plug all unused junction box holes. Never use knockout boxes or flexible conduit. Tighten all threaded connections and covers. Do not use gaskets with junction box covers. Do not disturb sealing compound around wires at junction box entrances. Use factory method of routing wires. Use tie wraps to keep unruly wires away from pinch point and hinges. Tuck wires into enclosure before closing doors, bezels, junction boxes, covers and breaker panels. Follow wiring recommendations in installation or service manuals.

### Proper Grounding is Required

Proper grounding is required for safe operation. See installation manual and applicable NEC, NFPA and local electrical codes for requirements.

### Avoid Pinched Wires

Pinched or cut wires (cables) may damage components. Exposed wires could create sparks and electrical shorts when applying power.

## Hydraulic Pressure Releases and Fuel Leakage

Working on hydraulic systems can result in leakage of fuel that may also be under pressure.



Turn off all circuit breakers for unit being worked on, all dispensers using the same grades of fuel, and all associated STPs.

Do not allow unauthorized or untrained individuals to service hydraulic equipment.

Shear valves, required by NFPA 30A, are intended to shut-off the flow of fuel at the dispenser base (hydraulics area) during vehicle impact or fires. A single-poppet shear valve prevents fuel from flowing from the underground tank. A double-poppet shear valve prevents fuel from flowing from the underground tank and from the dispenser.

## Protect Your Eyes



Spraying fuel from residual pressure in lines can cause serious eye injuries. Always wear eye protection. Gasoline spilled in eyes may cause burns to eye tissue. Rinse eyes with water for approximately 15 minutes. Seek medical advice immediately. It is not necessary to wear eye protection unless performing hydraulic service.

## React Quickly to Fuel Spills, Fires or Vehicle Impact

Follow these steps in the event of a fuel spill, fire, or vehicle impact.

- 1 Use station EMERGENCY TOTAL ELECTRICAL SHUT-OFF immediately. Turn off all system circuit breakers to the island.

### **WARNING**

The EMERGENCY STOP, ALL STOP, and PUMP STOP buttons at the cashier's station WILL NOT shut off electrical power to the pump/dispenser.



This means that even if you activate these stops, fuel may continue to flow uncontrolled.

You must use the TOTAL ELECTRICAL SHUT-OFF in the case of an emergency and not only these cashier station "stops."

- 2 Call emergency numbers for fires, vehicle impact or any significant spills.



- 3 Use safety tape, cones or barricades to block the work area. Do not go near fuel spill or allow anyone else in the area.

- 4  Take precautions to avoid igniting fuel. Do not allow starting of vehicles in the area and immediately stop use of open flames, smoking or power tools in the area.
- 5 Provide emergency and first aid assistance.

**⚠ WARNING**

If any gasoline has been inhaled, seek emergency help immediately.

Inhaled gasoline may cause unconsciousness and burns to lips, mouth and lungs.

**⚠ WARNING**

Gasoline spilled on skin may cause burns.

Wash area thoroughly with clean water.

Seek medical advice immediately.

- 6 Use approved and safe procedures to clean up all spills with a “fuel or gasoline absorbent” material approved by your local regulatory agencies. (Dispose of fuel and hazardous absorbent material promptly and according to the requirements of the fire department, local EPA, and federal, state or local resources.)

## Emergency and First Aid Information

Refer to phone book for emergency phone numbers. If needed, follow first aid instructions as outlined in American Red Cross Standard First Aid manuals.

**⚠ WARNING**



Gasoline ingested may cause unconsciousness and burns to internal organs.  
Do not induce vomiting.  
Keep airway open.  
Oxygen may be needed at scene.  
Seek medical advice immediately.

Gasoline  
Ingestion

**⚠ WARNING**



Gasoline inhaled may cause unconsciousness and burns to lips, mouth and lungs.  
Keep airway open.  
Seek medical advice immediately.

Gasoline Vapor  
Inhalation

**⚠ WARNING**



Gasoline spilled in eyes may cause burns to eye tissue.  
Irrigate eyes with water for approximately 15 minutes.  
Seek medical advice immediately

Gasoline In  
Eyes

**⚠ WARNING**



Gasoline spilled on skin may cause burns.  
Wash area thoroughly with clear/water.  
Seek medical advice immediately.

Gasoline On  
Skin



## Warning Labels

Several types of warning labels appear on Gilbarco products to inform and remind users of important safety information. Read, understand and follow these warnings.

### Sample Warning Label

The following labels are typical of those you may find on Gilbarco's products:

Warning	Mise en garde	Advertencia																																																
<p><b>Electrical shock hazard</b> Each electrical component within this unit may have its own circuit breaker or disconnect switch. Before servicing, turn off all circuit breakers and switches associated with this unit.</p>	<p><b>Danger de décharge électrique</b> Chaque composant électrique au sein de cet élément a son propre disjoncteur ou interrupteur pour couper l'électricité. Avant tout service d'entretien, couper tous les disjoncteurs et les interrupteurs contrôlant cet élément.</p>	<p><b>Peligro de shock eléctrico</b> Cada componente eléctrico en esta unidad puede tener su propio interruptor de circuito o interruptor para desconectar. Antes de darle mantenimiento, apague todos los interruptores asociados con esta unidad.</p>																																																
<p><b>Load Table</b></p> <table border="1"> <thead> <tr> <th></th> <th>115VAC</th> <th>240VAC</th> </tr> </thead> <tbody> <tr> <td>Includes all options (Less Motor)</td> <td>14.00 AMPS</td> <td>7.00 AMPS</td> </tr> <tr> <td>Upper Lights (for Eclipse models EG, EL, EN only)</td> <td>3.00 AMPS</td> <td>1.50 AMPS</td> </tr> </tbody> </table>		115VAC	240VAC	Includes all options (Less Motor)	14.00 AMPS	7.00 AMPS	Upper Lights (for Eclipse models EG, EL, EN only)	3.00 AMPS	1.50 AMPS	<p><b>La Table Des Charges</b></p> <table border="1"> <thead> <tr> <th></th> <th>115VAC</th> <th>240VAC</th> </tr> </thead> <tbody> <tr> <td>Toutes options incluses (Sans Moteur)</td> <td>14.00 AMPS</td> <td>7.00 AMPS</td> </tr> <tr> <td>Lumières du haut (pour les modèles Eclipse EG, EL, EN seulement)</td> <td>3.00 AMPS</td> <td>1.50 AMPS</td> </tr> </tbody> </table>		115VAC	240VAC	Toutes options incluses (Sans Moteur)	14.00 AMPS	7.00 AMPS	Lumières du haut (pour les modèles Eclipse EG, EL, EN seulement)	3.00 AMPS	1.50 AMPS	<p><b>Table De Consumo</b></p> <table border="1"> <thead> <tr> <th></th> <th>115VAC</th> <th>240VAC</th> </tr> </thead> <tbody> <tr> <td>Incluye todos los opciones (Menos Motor)</td> <td>14.00 AMPS</td> <td>7.00 AMPS</td> </tr> <tr> <td>Luces superiores (solamente para Eclipse models EG, EL, EN)</td> <td>3.00 AMPS</td> <td>1.50 AMPS</td> </tr> </tbody> </table>		115VAC	240VAC	Incluye todos los opciones (Menos Motor)	14.00 AMPS	7.00 AMPS	Luces superiores (solamente para Eclipse models EG, EL, EN)	3.00 AMPS	1.50 AMPS																					
	115VAC	240VAC																																																
Includes all options (Less Motor)	14.00 AMPS	7.00 AMPS																																																
Upper Lights (for Eclipse models EG, EL, EN only)	3.00 AMPS	1.50 AMPS																																																
	115VAC	240VAC																																																
Toutes options incluses (Sans Moteur)	14.00 AMPS	7.00 AMPS																																																
Lumières du haut (pour les modèles Eclipse EG, EL, EN seulement)	3.00 AMPS	1.50 AMPS																																																
	115VAC	240VAC																																																
Incluye todos los opciones (Menos Motor)	14.00 AMPS	7.00 AMPS																																																
Luces superiores (solamente para Eclipse models EG, EL, EN)	3.00 AMPS	1.50 AMPS																																																
<p><b>Motor Load Table</b> (F.L. AMPS)</p> <table border="1"> <thead> <tr> <th></th> <th>115VAC</th> <th>230VAC</th> <th>380VAC</th> </tr> </thead> <tbody> <tr> <td>3/4 HP 60HZ 1 PH</td> <td>12.5 AMPS</td> <td>6.3 AMPS</td> <td></td> </tr> <tr> <td>3/4 HP 50HZ 1 PH</td> <td>13.0 AMPS</td> <td>6.5 AMPS</td> <td></td> </tr> <tr> <td>3/4 HP 50HZ 3 PH</td> <td>3.4 AMPS</td> <td>2.3 AMPS</td> <td></td> </tr> </tbody> </table>		115VAC	230VAC	380VAC	3/4 HP 60HZ 1 PH	12.5 AMPS	6.3 AMPS		3/4 HP 50HZ 1 PH	13.0 AMPS	6.5 AMPS		3/4 HP 50HZ 3 PH	3.4 AMPS	2.3 AMPS		<p><b>La Table Des Charges Du Moteur</b> (F.L. AMPS)</p> <table border="1"> <thead> <tr> <th></th> <th>115VAC</th> <th>230VAC</th> <th>380VAC</th> </tr> </thead> <tbody> <tr> <td>3/4 HP 60HZ 1 PH</td> <td>12.5 AMPS</td> <td>6.3 AMPS</td> <td></td> </tr> <tr> <td>3/4 HP 50HZ 1 PH</td> <td>13.0 AMPS</td> <td>6.5 AMPS</td> <td></td> </tr> <tr> <td>3/4 HP 50HZ 3 PH</td> <td>3.4 AMPS</td> <td>2.3 AMPS</td> <td></td> </tr> </tbody> </table>		115VAC	230VAC	380VAC	3/4 HP 60HZ 1 PH	12.5 AMPS	6.3 AMPS		3/4 HP 50HZ 1 PH	13.0 AMPS	6.5 AMPS		3/4 HP 50HZ 3 PH	3.4 AMPS	2.3 AMPS		<p><b>Table De Consumo De Motores</b> (F.L. AMPS)</p> <table border="1"> <thead> <tr> <th></th> <th>115VAC</th> <th>230VAC</th> <th>380VAC</th> </tr> </thead> <tbody> <tr> <td>3/4 HP 60HZ 1 PH</td> <td>12.5 AMPS</td> <td>6.3 AMPS</td> <td></td> </tr> <tr> <td>3/4 HP 50HZ 1 PH</td> <td>13.0 AMPS</td> <td>6.5 AMPS</td> <td></td> </tr> <tr> <td>3/4 HP 50HZ 3 PH</td> <td>3.4 AMPS</td> <td>2.3 AMPS</td> <td></td> </tr> </tbody> </table>		115VAC	230VAC	380VAC	3/4 HP 60HZ 1 PH	12.5 AMPS	6.3 AMPS		3/4 HP 50HZ 1 PH	13.0 AMPS	6.5 AMPS		3/4 HP 50HZ 3 PH	3.4 AMPS	2.3 AMPS	
	115VAC	230VAC	380VAC																																															
3/4 HP 60HZ 1 PH	12.5 AMPS	6.3 AMPS																																																
3/4 HP 50HZ 1 PH	13.0 AMPS	6.5 AMPS																																																
3/4 HP 50HZ 3 PH	3.4 AMPS	2.3 AMPS																																																
	115VAC	230VAC	380VAC																																															
3/4 HP 60HZ 1 PH	12.5 AMPS	6.3 AMPS																																																
3/4 HP 50HZ 1 PH	13.0 AMPS	6.5 AMPS																																																
3/4 HP 50HZ 3 PH	3.4 AMPS	2.3 AMPS																																																
	115VAC	230VAC	380VAC																																															
3/4 HP 60HZ 1 PH	12.5 AMPS	6.3 AMPS																																																
3/4 HP 50HZ 1 PH	13.0 AMPS	6.5 AMPS																																																
3/4 HP 50HZ 3 PH	3.4 AMPS	2.3 AMPS																																																

## Working Alone

It is highly recommended that someone who is capable of rendering first aid be present during servicing. Be familiar with Cardiopulmonary Resuscitation (CPR) methods if you are working with or around high voltages. This information is available from the American Red Cross. Always advise the station personnel about where you will be working, and caution them not to activate power while you are working on the equipment. Use the OSHA tag out and lock out procedures discussed later in this section.

## Contacting Emergency Personnel

Keep the following emergency phone numbers at hand.

**Ambulance:** \_\_\_\_\_

**Fire:** \_\_\_\_\_

**Police:** \_\_\_\_\_

**Poison Control Center:** \_\_\_\_\_

## Informing Emergency Personnel

Compile the following information for emergency personnel:

- Location of accident (e.g. address, front/back of building, etc.)
- Nature of accident (e.g. possible heart attack, run over by car, burns, etc.)
- Age of victim (e.g. baby, teenager, middle-age, elderly)
- Whether or not victim has received first aid (e.g. stopped bleeding by pressure, etc.)
- Whether or not victim has vomited (e.g. if swallowed or inhaled something, etc.)

**IMPORTANT:** Oxygen may be needed at scene if gasoline has been ingested or inhaled. Seek medical advice immediately.

## Other Useful Safety Information

This subsection provides additional safety information.

### OSHA Lock-Out and Tag-Out Requirements

OSHA Standard 29 CFR 1910-147 Control of Hazardous Energy Sources (Lock-Out/Tag-Out) covers ways to avoid personal injury because power was turned on or fuel pressure was applied **unexpectedly** while servicing equipment. The rule requires:

- (1) Turning off equipment power and fuel under pressure.
- (2) Use of a locking device (breaker, valve, etc.) or label device with a warning tag.

Station employees and service contractors need to understand and comply with this program completely to ensure safety while the equipment is down.

### Breakaways

Required by NFPA 30A, breakaways are emergency devices designed to retain liquid on both sides of the breakaway point installed on each hose. Refer to manufacturer's instructions for proper installation.

### Collection of Fuel in Approved Containers

NFPA 30A, Section 2, requires use of approved containers to collect, transport, and dispose of fuel. Containers must be specifically designed and labeled for handling hazardous fuels.

### Read Material Safety Data Sheets (MSDS)

Before working with any chemicals or fuels in and around a dispensing facility, read the MSDS pertaining to those chemicals as prescribed in the Occupational Safety and Health Administration Standard, 29 CFR 1910.1200. Refer to the supplier's literature.

### Replacement Parts

Use only genuine Gilbarco replacement parts and retrofit kits on your pump/dispenser. Using parts other than genuine Gilbarco replacement parts could create a safety hazard and violate local regulations.

# Speaker Installation

## Preparing for Installation

- 1 Before proceeding, read and follow all safety instructions and procedures.
- 2 Open main access doors. Refer to MDE-3804, Encore and Eclipse Start-up/Service Manual for access instructions.

## Installation Instructions

- 1 Place the speaker assembly over the three speaker mounts in the upper right hand corner of the CIM door panel. Align the holes in speaker assembly with the speaker mounts.
- 2 Secure the speaker assembly to the door panel using the three screws. Each screw should pass through the hole in the speaker assembly into the speaker mount. See Figure 1.

**Figure 1: CIM Door with Speaker Assembly**

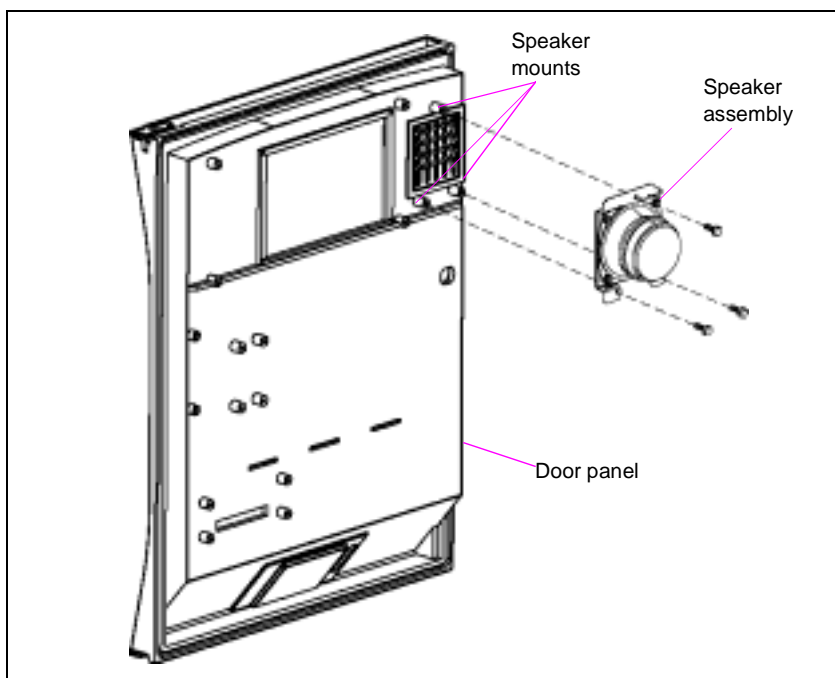

- 3 Tighten the screws.

- 4 Route wiring along the back of the CIM door. The wiring should pass behind the main bezel door to the right side of the electronics cabinet along the center brace of the cabinet.

*Note: For European markets only: If the intercom or speaker electronics do not meet EN 60950, the speaker wiring must be separate from all other wiring.*

### **CAUTION**

Do **NOT** connect the wiring through the main conduit.

- 5 Install a sealing conduit per MDE-3985 Encore Installation manual. Do not connect the wiring through the main conduit.
- 6 Connect the sealing conduit to the station conduit per MDE-3985 Encore Installation manual.

## Completing Installation

- 1 Close and secure main door.
- 2 Restore power to unit. Refer to MDE-3804 Encore and Eclipse Start-up/Service Manual for access instructions.

## Trademark Information

- Eclipse™ is a trademark of Gilbarco Inc.
- Encore™ is a trademark of Gilbarco Inc.
- GOLD<sup>(SM)</sup> is a service mark of Gilbarco Inc.