

Introduction

Purpose

This document provides instructions to install the Gilbarco® Secure Payment Outdoor Terminal (SPOT) Retrofit Kit in Wayne® 3V399 and 3V387 units.

Table of Contents

Topic	Page
Introduction	1
Important Safety Information	3
Installing the Gilbarco SPOT Retrofit Kit	5
Cable Connections	9

Overview

This kit is used for the installation of the Wayne Retrofit kit in Wayne pumps installed at sites. This kit is also used for pedestal installations which are used where the retrofit kit cannot be installed in the pump.

Hardware

The Gilbarco SPOT Retrofit kit for Wayne dispensers consists of a door together with a frame. The components in the Gilbarco SPOT Retrofit kit are shown in [Figure 1](#).

Figure 1: Gilbarco SPOT Retrofit Kit for Wayne Dispensers

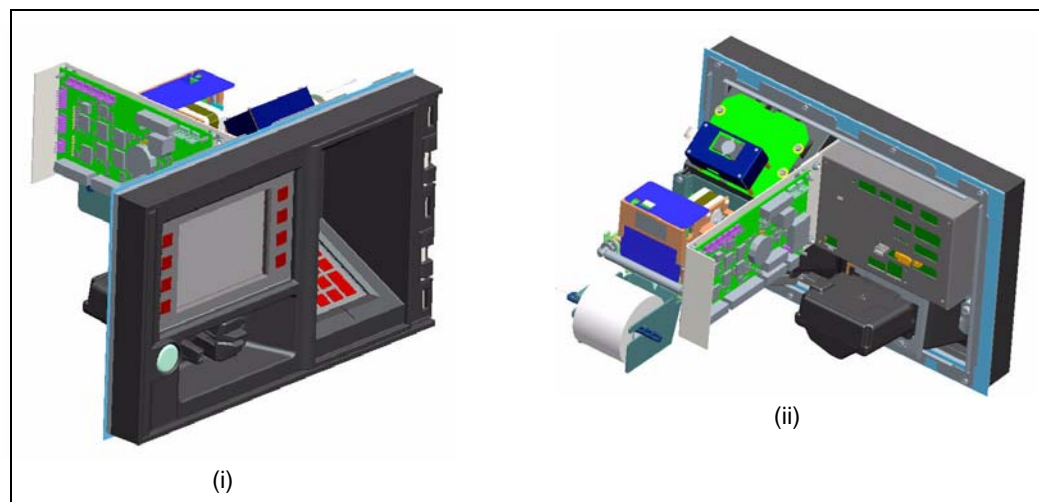

Required Tools

Following tools are required for the installation of the Gilbarco SPOT Retrofit Kit in Wayne dispensers:

- Pneumatic Drill
- 4 mm Drill Bit
- 1/4" Nut Driver (screws supplied in the kit are of imperial sizes)

Parts List

Following table lists the parts included in this kit.

Item	Description	Part Number	Quantity
1	Screw, Hexagonal Washer Head, Thread Forming	Q11677-28	8
2	Assembly, EMV® Bezel, (Wayne)	M12303A001	1
3	PTGP, CRIND® Door Assembly	PKM12303A001	1
4	PTGP, EMV Door Assembly	PKM10278A007	1
5	PTGP, Printer Upgrade	PKM10278A006	1
6	PTGP, Power Supply	PKM10278A008	1
7	PTGP, Preset Keypad	PKM12311A001	1
8	PTGP, Contactless Card*	PKM10353A006	1
9	Wayne R/F EMV Card Reader**	WRF0101G001	1
10	Wayne R/F EMV RCPT Printer**	WRF0102G001	1
11	Wayne R/F EMV Hinge BLNK**	WRF0103G001	1

*Optional

**Graphics

Abbreviations and Acronyms

Term	Description
EMV	Europay MasterCard® Visa®
SPOT	Secure Payment Outdoor Terminal

Important Safety Information

Notes: 1) *Save this Important Safety Information section in a readily accessible location.*

2) *Although DEF is non-flammable, Diesel is flammable. Therefore, for DEF cabinets that are attached to Diesel dispensers, follow all the notes in this section that pertain to flammable fuels.*

This section introduces the hazards and safety precautions associated with installing, inspecting, maintaining, or servicing this product. Before performing any task on this product, read this safety information and the applicable sections in this manual, where additional hazards and safety precautions for your task will be found. Fire, explosion, electrical shock, or pressure release could occur and cause death or serious injury, if these safe service procedures are not followed.

Preliminary Precautions

You are working in a potentially dangerous environment of flammable fuels, vapors, and high voltage or pressures. Only trained or authorized individuals knowledgeable in the related procedures should install, inspect, maintain, or service this equipment.

Emergency Total Electrical Shut-Off

The first and most important information you must know is how to stop all fuel flow to the pump/dispenser and island. Locate the switch or circuit breakers that shut off all power to all fueling equipment, dispensing devices, and Submerged Turbine Pumps (STPs).

⚠ WARNING

 The EMERGENCY STOP, ALL STOP, and PUMP STOP buttons at the cashier's station WILL NOT shut off electrical power to the pump/dispenser. This means that even if you activate these stops, fuel may continue to flow uncontrolled.



You must use the TOTAL ELECTRICAL SHUT-OFF in the case of an emergency and not the console's ALL STOP and PUMP STOP or similar keys.

Total Electrical Shut-Off Before Access

Any procedure that requires access to electrical components or the electronics of the dispenser requires total electrical shut off of that unit. Understand the function and location of this switch or circuit breaker before inspecting, installing, maintaining, or servicing Gilbarco equipment.

Evacuating, Barricading, and Shutting Off

Any procedure that requires access to the pump/dispenser or STPs requires the following actions:



- An evacuation of all unauthorized persons and vehicles from the work area
- Use of safety tape, cones, or barricades at the affected unit(s)
- A total electrical shut-off of the affected unit(s)

Read the Manual

Read, understand, and follow this manual and any other labels or related materials supplied with this equipment. If you do not understand a procedure, call a Gilbarco Authorized Service Contractor or call the Gilbarco Support Center at 1-800-800-7498. It is imperative to your safety and the safety of others to understand the procedures before beginning work.

Follow the Regulations

Applicable information is available in National Fire Protection Association (NFPA) 30A; *Code for Motor Fuel Dispensing Facilities and Repair Garages*, NFPA 70; *National Electrical Code (NEC)*, Occupational Safety and Hazard Association (OSHA) regulations and federal, state, and local codes. All these regulations must be followed. Failure to install, inspect, maintain, or service this equipment in accordance with these codes, regulations, and standards may lead to legal citations with penalties or affect the safe use and operation of the equipment.

Replacement Parts

Use only genuine Gilbarco replacement parts and retrofit kits on your pump/dispenser. Using parts other than genuine Gilbarco replacement parts could create a safety hazard and violate local regulations.

Safety Symbols and Warning Words

This section provides important information about warning symbols and boxes.

Alert Symbol



This safety alert symbol is used in this manual and on warning labels to alert you to a precaution which must be followed to prevent potential personal safety hazards. Obey safety directives that follow this symbol to avoid possible injury or death.

Signal Words

These signal words used in this manual and on warning labels tell you the seriousness of particular safety hazards. The precautions below must be followed to prevent death, injury, or damage to the equipment:



DANGER: Alerts you to a hazard or unsafe practice which will result in death or serious injury.



WARNING: Alerts you to a hazard or unsafe practice that could result in death or serious injury.



CAUTION with Alert symbol: Designates a hazard or unsafe practice which may result in minor injury.

CAUTION without Alert symbol: Designates a hazard or unsafe practice which may result in property or equipment damage.

Working With Fuels and Electrical Energy

Prevent Explosions and Fires

Fuels and their vapors will explode or burn, if ignited. Spilled or leaking fuels cause vapors. Even filling customer tanks will cause potentially dangerous vapors in the vicinity of the dispenser or island.

DEF is non-flammable. Therefore, explosion and fire safety warnings do not apply to DEF lines.

Important Safety Information

No Open Fire



Open flames from matches, lighters, welding torches, or other sources can ignite fuels and their vapors.

No Sparks - No Smoking



Sparks from starting vehicles, starting, or using power tools, burning cigarettes, cigars, or pipes can also ignite fuels and their vapors. Static electricity, including an electrostatic charge on your body, can cause a spark sufficient to ignite fuel vapors. Every time you get out of a vehicle, touch the metal of your vehicle, to discharge any electrostatic charge before you approach the dispenser island.

Working Alone

It is highly recommended that someone who is capable of rendering first aid be present during servicing. Familiarize yourself with Cardiopulmonary Resuscitation (CPR) methods, if you work with or around high voltages. This information is available from the American Red Cross. Always advise the station personnel about where you will be working, and caution them not to activate power while you are working on the equipment. Use the OSHA Lockout/Tagout procedures. If you are not familiar with this requirement, refer to this information in the service manual and OSHA documentation.

Working With Electricity Safely

Ensure that you use safe and established practices in working with electrical devices. Poorly wired devices may cause a fire, explosion, or electrical shock. Ensure that grounding connections are properly made. Take care that sealing devices and compounds are in place. Ensure that you do not pinch wires when replacing covers. Follow OSHA Lockout/Tagout requirements. Station employees and service contractors need to understand and comply with this program completely to ensure safety while the equipment is down.

Hazardous Materials

Some materials present inside electronic enclosures may present a health hazard if not handled correctly. Ensure that you clean hands after handling equipment. Do not place any equipment in the mouth.

WARNING

The pump/dispenser contains a chemical known to the State of California to cause cancer.

WARNING

The pump/dispenser contains a chemical known to the State of California to cause birth defects or other reproductive harm.

In an Emergency

Inform Emergency Personnel

Compile the following information and inform emergency personnel:

- Location of accident (for example, address, front/back of building, and so on)
- Nature of accident (for example, possible heart attack, run over by car, burns, and so on)
- Age of victim (for example, baby, teenager, middle-age, elderly)
- Whether or not victim has received first aid (for example, stopped bleeding by pressure, and so on)
- Whether or not a victim has vomited (for example, if swallowed or inhaled something, and so on)

WARNING



Gasoline/DEF ingested may cause unconsciousness and burns to internal organs. Do not induce vomiting. Keep airway open. Oxygen may be needed at scene. Seek medical advice immediately.

WARNING

DEF generates ammonia gas at higher temperatures. When opening enclosed panels, allow the unit to air out to avoid breathing vapors. If respiratory difficulties develop, move victim away from source of exposure and into fresh air. If symptoms persist, seek medical attention.

WARNING



Gasoline inhaled may cause unconsciousness and burns to lips, mouth, and lungs. Keep airway open. Seek medical advice immediately.

WARNING



Gasoline/DEF spilled in eyes may cause burns to eye tissue. Irrigate eyes with water for approximately 15 minutes. Seek medical advice immediately.

WARNING



Gasoline/DEF spilled on skin may cause burns. Wash area thoroughly with clear water. Seek medical advice immediately.

WARNING

DEF is mildly corrosive. Avoid contact with eyes, skin, and clothing. Ensure that eyewash stations and safety showers are close to the work location. Seek medical advice/recommended treatment if DEF spills into eyes.

IMPORTANT: Oxygen may be needed at scene if gasoline has been ingested or inhaled. Seek medical advice immediately.

Lockout/Tagout

Lockout/Tagout covers servicing and maintenance of machines and equipment in which the unexpected energization or start-up of the machine(s) or equipment or release of stored energy could cause injury to employees or personnel. Lockout/Tagout applies to all mechanical, hydraulic, chemical, or other energy, but does not cover electrical hazards. Subpart S of 29 CFR Part 1910 - Electrical Hazards, 29 CFR Part 1910.333 contains specific Lockout/Tagout provision for electrical hazards.

Installing the Gilbarco SPOT Retrofit Kit

To install the Gilbarco SPOT Retrofit kit in Wayne dispensers, proceed as follows:

- 1 Drill eight mounting holes (4 mm diameter) on the Wayne Bezel using metal support bracket as a template [see [Figure 2 \(i\)](#)].

⚠ WARNING

 Use of electric tools must be avoided on the island. Always use a Pneumatic drill gun.

Figure 2: Drilling the Mounting Holes on the Wayne Bezel



The mounting holes to be drilled on the Wayne bezel are shown in [Figure 3](#).

Figure 3: Mounting Holes Required on the Wayne Bezel

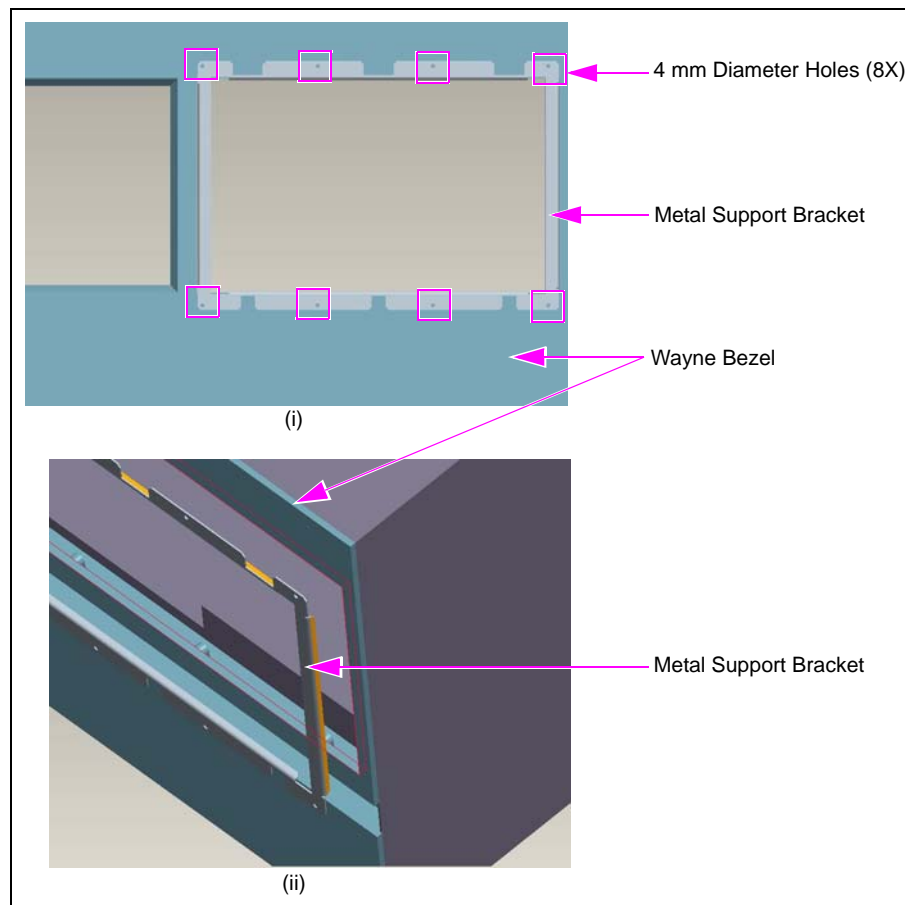
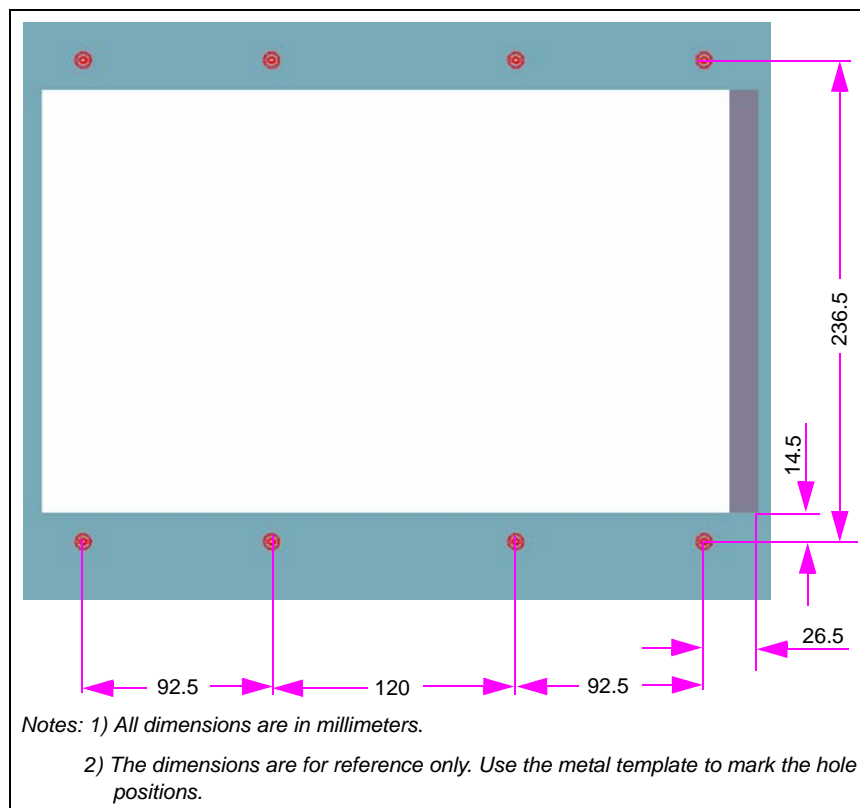

2 Mount the bezel and frame on the front side of the dispenser (see [Figure 4](#)).

After drilling holes, transfer the template to the rear face of the dispenser bezel. Assemble the retrofit kit using eight Q11677-28 screws. If the dispenser bezel is damaged to a point where the kit will not seal, use the flat sealing plate included in the kit. Seal the plate to the bezel with Silicone.

Figure 4: Mounting the Bezel and Frame

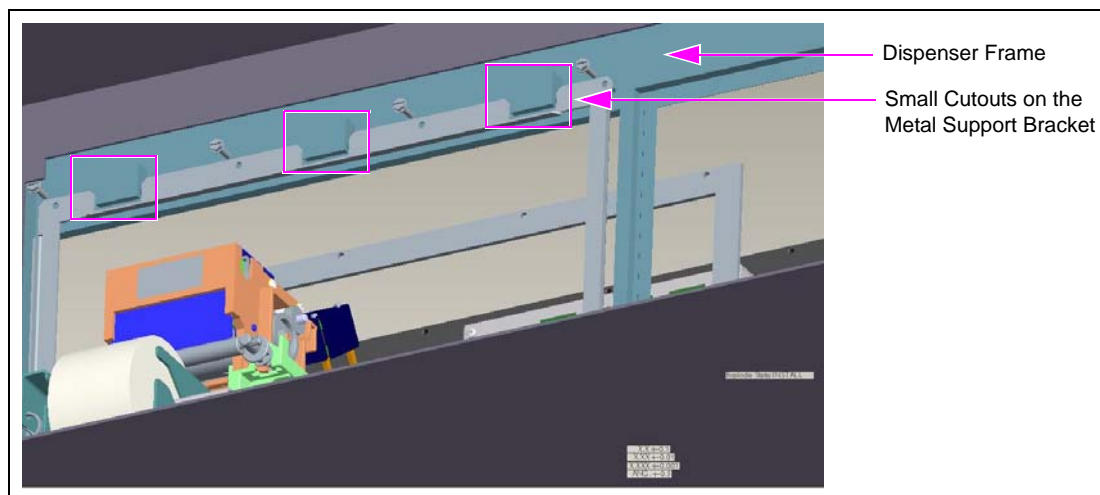

Ensure that the lock is kept in a horizontal position when mounting the bezel as shown in [Figure 5](#).

Figure 5: Position of the Lock when Mounting the Bezel

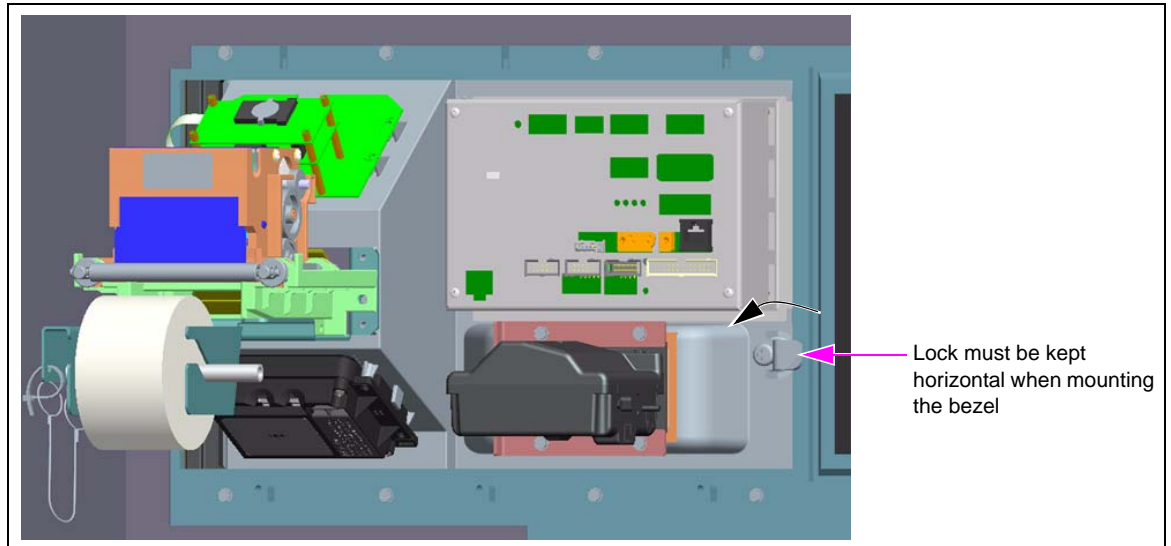

- 3 Insert the Q11677-28 screws through the metal support bracket and dispenser frame, and then tighten the screws (see [Figure 6](#)).

Figure 6: Inserting the Screw through the Supporting Bracket

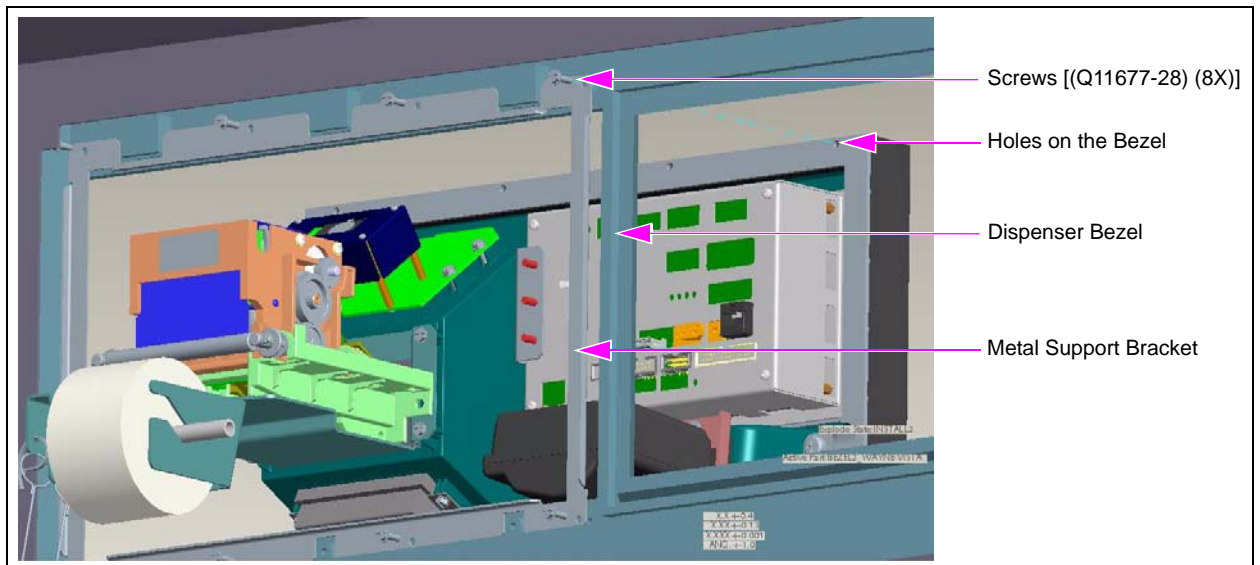

Figure 7: Gilbarco SPOT Retrofit Kit in Wayne Dispenser

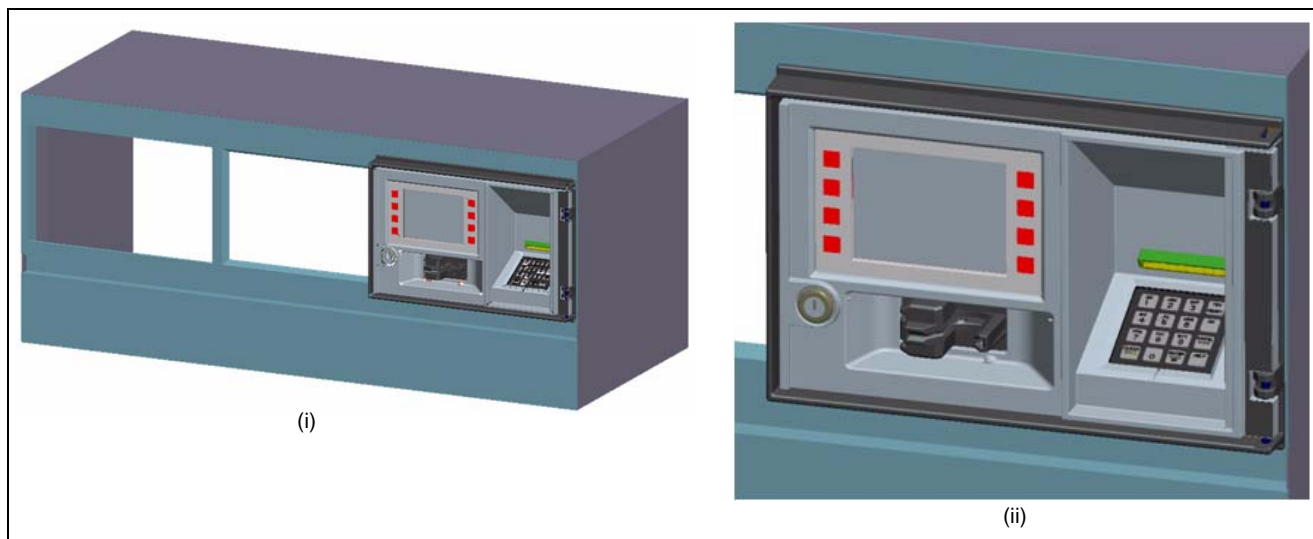
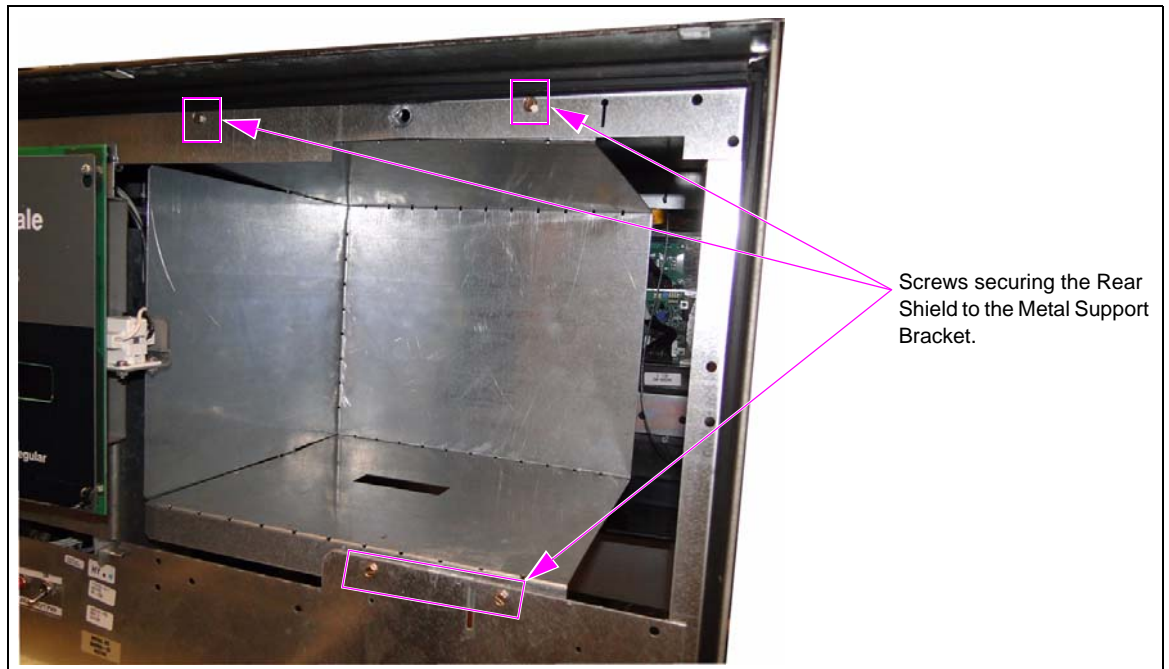

Figure 8: Rear Shield



Install the shield to the dispenser frame using the four screws as shown in [Figure 9](#).

Figure 9: Installed Rear Shield



Cable Connections

Connect the Ethernet Cable from the lightning barrier to the Ethernet Port on the SPOT display.

Note: An Ethernet Splitter Cable may be present from the lightning barrier if there are two SPOT displays to support.

Power Supply Installation

Place the power supply in a suitable location inside Wayne pump and route cables without causing interference to existing wiring.

The installation of the Gilbarco SPOT Retrofit kit in Wayne dispenser is now complete (see [Figure 7](#) on [page 8](#)).

CRIND® and Gilbarco® are registered trademarks of Gilbarco Inc. EMV® is a registered trademark of EMVCo LLC. MasterCard® is a registered trademark of MasterCard International Inc. Visa® is a registered trademark of Visa Inc. Wayne® is a registered trademark of Dresser Equipment Group Inc.



© 2012 Gilbarco Inc.
7300 West Friendly Avenue · Post Office Box 22087
Greensboro, North Carolina 27420
Phone (336) 547-5000 · <http://www.gilbarco.com> · Printed in the U.S.A.
MDE-5002 Gilbarco® SPOT Retrofit Kit for Wayne® Dispensers · February 2012