

Introduction

Purpose

This manual provides instructions to install the Printer Replacement Kit (M10063K002) in The Advantage® Series unit.

Table of Contents

| Topic | Page |
|---|------|
| Introduction | 1 |
| Important Safety Information | 3 |
| Before You Begin | 5 |
| Installing Printer Replacement Kit (M10063K002) | 6 |

Required Tools

Following tools and materials are required for installing the Printer Replacement Kit:

- 8 mm Wrench
- 8 mm and 3/8-inch Socket or Nut Driver

Parts List

Following table lists the parts included in the Printer Replacement Kit:

| Item | Description | Part Number | Quantity |
|------|--|-------------|----------|
| 1 | Assembly, Advantage Hengstler® Printer | M10063A002 | 1 |
| 2 | Printer, Hengstler Components | M13832A002 | 1 |
| 3 | Assembly, Advantage Printer | M13832K002 | 1 |
| 4 | Assembly, Hengstler Printer, Bracket Adapter | M09924A001 | 1 |
| 5 | Bracket, Advantage Hengstler Printer | M09280B001 | 1 |
| 6 | Cable Mount, Adhesive | Q13558-04 | 1 |
| 7 | Cable, Low Paper Hengstler Printer Encore® 300 | M14132A001 | 1 |
| 8 | Gasket, Printer Chute | M06908B002 | 1 |
| 9 | Gasket, Left Option Door Printer | M10351B002 | 1 |
| 10 | Hinge Pin, Printer | M07044B001 | 1 |
| 11 | Hinge Pin, Printer | M07044B002 | 1 |
| 12 | Fastener Super Secure 8311 | M12420B001 | 1 |
| 13 | Paper, Printer Circuit Protection | M09138B001 | 1 |
| 14 | Clip Printer Shaft | M13817B001 | 4 |
| 15 | Spool, Paper Roll 6" Printer | M07884B002 | 1 |
| 16 | Tube Printer Spacer | M07234B001 | 1 |

| Item | Description | Part Number | Quantity |
|------|---|-------------|----------|
| 17 | Cable, Universal Serial Bus (USB)/Ground/+24V Hengstler Printer | M06745A001 | 1 |
| 18 | Cable Assembly, Hengstler Printer Encore 300 | M14133A001 | 1 |
| 19 | Label, Printer Paper Loading/Replacement | M10346B001 | 1 |
| 20 | Nut, Metric Hexagonal Serrated Flange | M00414B001 | 4 |
| 21 | Screw, Metric Serrated Flange Hexagonal-head | M00415B003 | 4 |
| 22 | Printer Paper Thermal | M04809B015 | 1 |
| 23 | Clamp, Releasable Flat Cable Mounting | Q13459-01 | 1 |

Related Documents

| Document Number | Title | GOLD SM Library |
|-----------------|--|---|
| MDE-2531 | Gilbarco® Pump and Dispenser Start-up and Service Manual | <ul style="list-style-type: none">• Pump & Dispenser Start-up & Service Manual• Service Manual |
| MDE-2540 | The Advantage, Legacy®, and MPD® Series Owner's Manual | <ul style="list-style-type: none">• Advantage & Legacy Models• Domestic Warranty and Owners Manuals• Export Warranty and Owners Manuals |
| PT-1728 | The Advantage Series Pumps and Dispensers Illustrated Parts Manual | Parts Manual |

Abbreviations and Acronyms

| Term | Description |
|--------|---|
| BIOS | Basic Input/Output System |
| CRIND® | Card Reader in Dispenser |
| ESD | Electrostatic Discharge |
| GOLD | Gilbarco Online Documentation |
| OSHA | Occupational Safety and Health Administration |
| USB | Universal Serial Bus |

Important Safety Information

Notes: 1) Save this Important Safety Information section in a readily accessible location.

2) Although DEF is non-flammable, Diesel is flammable. Therefore, for DEF cabinets that are attached to Diesel dispensers, follow all the notes in this section that pertain to flammable fuels.

This section introduces the hazards and safety precautions associated with installing, inspecting, maintaining, or servicing this product. Before performing any task on this product, read this safety information and the applicable sections in this manual, where additional hazards and safety precautions for your task will be found. Fire, explosion, electrical shock, or pressure release could occur and cause death or serious injury, if these safe service procedures are not followed.

Preliminary Precautions

You are working in a potentially dangerous environment of flammable fuels, vapors, and high voltage or pressures. Only trained or authorized individuals knowledgeable in the related procedures should install, inspect, maintain, or service this equipment.

Emergency Total Electrical Shut-Off

The first and most important information you must know is how to stop all fuel flow to the pump/dispenser and island. Locate the switch or circuit breakers that shut off all power to all fueling equipment, dispensing devices, and Submerged Turbine Pumps (STPs).

⚠ WARNING

 The EMERGENCY STOP, ALL STOP, and PUMP STOP buttons at the cashier's station WILL NOT shut off electrical power to the pump/dispenser. This means that even if you activate these stops, fuel may continue to flow uncontrolled.

 You must use the TOTAL ELECTRICAL SHUT-OFF in the case of an emergency and not the console's ALL STOP and PUMP STOP or similar keys.

Total Electrical Shut-Off Before Access

Any procedure that requires access to electrical components or the electronics of the dispenser requires total electrical shut off of that unit. Understand the function and location of this switch or circuit breaker before inspecting, installing, maintaining, or servicing Gilbarco equipment.

Evacuating, Barricading, and Shutting Off

Any procedure that requires access to the pump/dispenser or STPs requires the following actions:



- An evacuation of all unauthorized persons and vehicles from the work area
- Use of safety tape, cones, or barricades at the affected unit(s)
- A total electrical shut-off of the affected unit(s)

Read the Manual

Read, understand, and follow this manual and any other labels or related materials supplied with this equipment. If you do not understand a procedure, call a Gilbarco Authorized Service Contractor or call the Gilbarco Support Center at 1-800-800-7498. It is imperative to your safety and the safety of others to understand the procedures before beginning work.

Follow the Regulations

Applicable information is available in National Fire Protection Association (NFPA) 30A; *Code for Motor Fuel Dispensing Facilities and Repair Garages*, NFPA 70; *National Electrical Code (NEC)*, Occupational Safety and Health Administration (OSHA) regulations and federal, state, and local codes. All these regulations must be followed. Failure to install, inspect, maintain, or service this equipment in accordance with these codes, regulations, and standards may lead to legal citations with penalties or affect the safe use and operation of the equipment.

Replacement Parts

Use only genuine Gilbarco replacement parts and retrofit kits on your pump/dispenser. Using parts other than genuine Gilbarco replacement parts could create a safety hazard and violate local regulations.

Safety Symbols and Warning Words

This section provides important information about warning symbols and boxes.

Alert Symbol



This safety alert symbol is used in this manual and on warning labels to alert you to a precaution which must be followed to prevent potential personal safety hazards. Obey safety directives that follow this symbol to avoid possible injury or death.

Signal Words

These signal words used in this manual and on warning labels tell you the seriousness of particular safety hazards. The precautions below must be followed to prevent death, injury, or damage to the equipment:



DANGER: Alerts you to a hazard or unsafe practice which will result in death or serious injury.



WARNING: Alerts you to a hazard or unsafe practice that could result in death or serious injury.



CAUTION with Alert symbol: Designates a hazard or unsafe practice which may result in minor injury.

CAUTION without Alert symbol: Designates a hazard or unsafe practice which may result in property or equipment damage.

Working With Fuels and Electrical Energy

Prevent Explosions and Fires

Fuels and their vapors will explode or burn, if ignited. Spilled or leaking fuels cause vapors. Even filling customer tanks will cause potentially dangerous vapors in the vicinity of the dispenser or island.

DEF is non-flammable. Therefore, explosion and fire safety warnings do not apply to DEF lines.

Important Safety Information

No Open Fire



Open flames from matches, lighters, welding torches, or other sources can ignite fuels and their vapors.

No Sparks - No Smoking



Sparks from starting vehicles, starting, or using power tools, burning cigarettes, cigars, or pipes can also ignite fuels and their vapors. Static electricity, including an electrostatic charge on your body, can cause a spark sufficient to ignite fuel vapors. Every time you get out of a vehicle, touch the metal of your vehicle, to discharge any electrostatic charge before you approach the dispenser island.

Working Alone

It is highly recommended that someone who is capable of rendering first aid be present during servicing. Familiarize yourself with Cardiopulmonary Resuscitation (CPR) methods, if you work with or around high voltages. This information is available from the American Red Cross. Always advise the station personnel about where you will be working, and caution them not to activate power while you are working on the equipment. Use the OSHA Lockout/Tagout procedures. If you are not familiar with this requirement, refer to this information in the service manual and OSHA documentation.

Working With Electricity Safely

Ensure that you use safe and established practices in working with electrical devices. Poorly wired devices may cause a fire, explosion, or electrical shock. Ensure that grounding connections are properly made. Take care that sealing devices and compounds are in place. Ensure that you do not pinch wires when replacing covers. Follow OSHA Lockout/Tagout requirements. Station employees and service contractors need to understand and comply with this program completely to ensure safety while the equipment is down.

Hazardous Materials

Some materials present inside electronic enclosures may present a health hazard if not handled correctly. Ensure that you clean hands after handling equipment. Do not place any equipment in the mouth.

WARNING

The pump/dispenser contains a chemical known to the State of California to cause cancer.

WARNING

The pump/dispenser contains a chemical known to the State of California to cause birth defects or other reproductive harm.

In an Emergency

Inform Emergency Personnel

Compile the following information and inform emergency personnel:

- Location of accident (for example, address, front/back of building, and so on)
- Nature of accident (for example, possible heart attack, run over by car, burns, and so on)
- Age of victim (for example, baby, teenager, middle-age, elderly)
- Whether or not victim has received first aid (for example, stopped bleeding by pressure, and so on)
- Whether or not a victim has vomited (for example, if swallowed or inhaled something, and so on)

WARNING



Gasoline/DEF ingested may cause unconsciousness and burns to internal organs. Do not induce vomiting. Keep airway open. Oxygen may be needed at scene. Seek medical advice immediately.

WARNING

DEF generates ammonia gas at higher temperatures. When opening enclosed panels, allow the unit to air out to avoid breathing vapors. If respiratory difficulties develop, move victim away from source of exposure and into fresh air. If symptoms persist, seek medical attention.

WARNING



Gasoline inhaled may cause unconsciousness and burns to lips, mouth, and lungs. Keep airway open. Seek medical advice immediately.

WARNING



Gasoline/DEF spilled in eyes may cause burns to eye tissue. Irrigate eyes with water for approximately 15 minutes. Seek medical advice immediately.

WARNING



Gasoline/DEF spilled on skin may cause burns. Wash area thoroughly with clear water. Seek medical advice immediately.

WARNING

DEF is mildly corrosive. Avoid contact with eyes, skin, and clothing. Ensure that eyewash stations and safety showers are close to the work location. Seek medical advice/recommended treatment if DEF spills into eyes.

IMPORTANT: Oxygen may be needed at scene if gasoline has been ingested or inhaled. Seek medical advice immediately.

Lockout/Tagout

Lockout/Tagout covers servicing and maintenance of machines and equipment in which the unexpected energization or start-up of the machine(s) or equipment or release of stored energy could cause injury to employees or personnel. Lockout/Tagout applies to all mechanical, hydraulic, chemical, or other energy, but does not cover electrical hazards. Subpart S of 29 CFR Part 1910 - Electrical Hazards, 29 CFR Part 1910.333 contains specific Lockout/Tagout provision for electrical hazards

Before You Begin

Read and understand all safety information found in *MDE-2531 Gilbarco Pump and Dispenser Start-up and Service Manual*.

CAUTION



A properly grounded Electrostatic Discharge (ESD) wrist strap must be worn while servicing any electronic devices or components. Failure to use electrostatic precautions may damage electronic components and void warranty.

To prepare the site and dispenser for the installation, proceed as follows:

- 1 Inform the manager.
- 2 Barricade the unit to be worked on.
- 3 Remove power to the unit at the breaker panel. Follow OSHA lockout/tagout procedures.
- 4 Match the parts received in the kit with [“Parts List”](#) on [page 1](#).



WARNING

Failure to turn off the unit during kit installation may cause injury or bodily harm from electrical shock. Ensure that all power to the unit is switched off before opening the door to the unit and during kit installation.

Installing Printer Replacement Kit (M10063K002)

To install the Printer Replacement Kit, proceed as follows:

Figure 1: Advantage Hengstler Printer Assembly

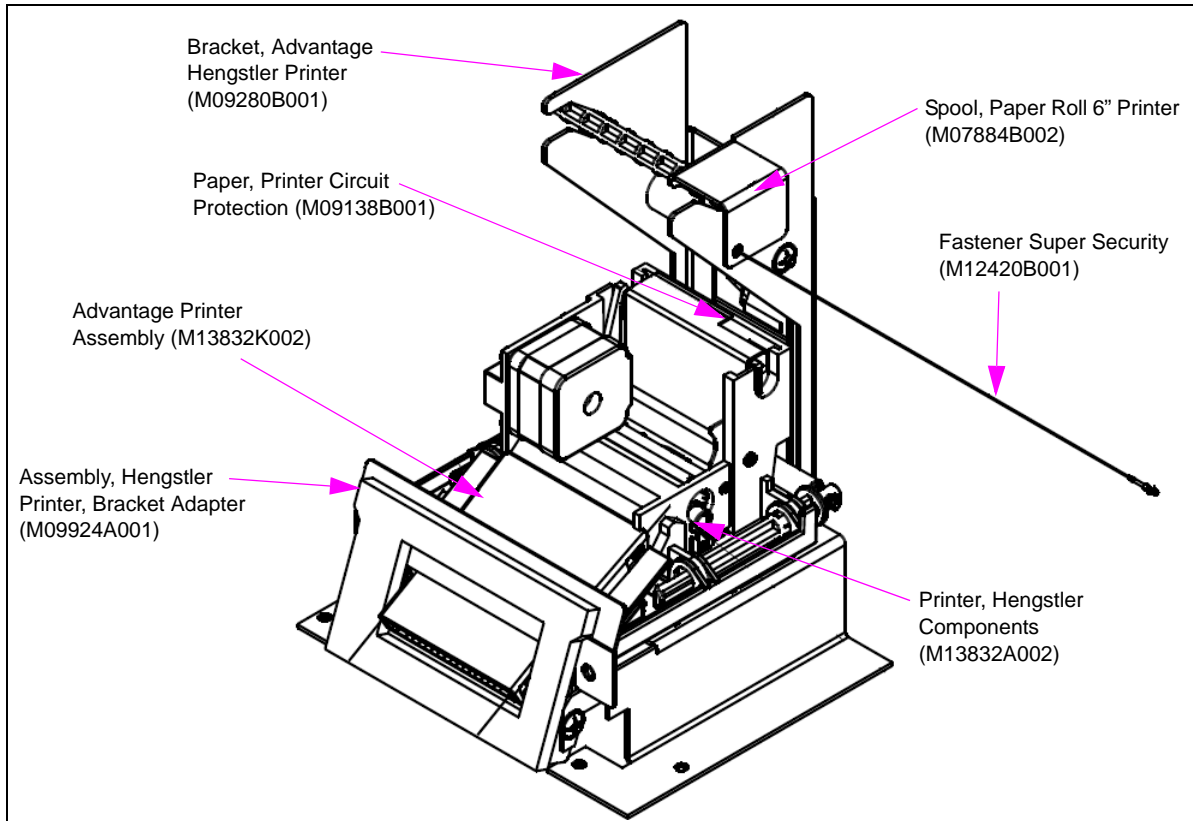

Removing Existing Printer

To remove the existing printer, proceed as follows:

- 1 Disconnect the cables attached to the existing printer (see [Figure 2](#)).

Figure 2: Printer Cabinet

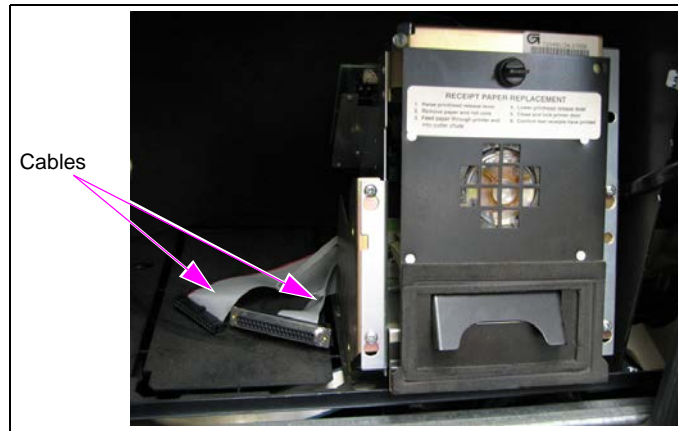

- 2 Remove the retaining hardware and remove the printer from unit. You will also need to loosen/remove the nut holding the CRIND tray.

Installing New Printer

To install the new printer, proceed as follows:

- 1 Insert the new printer module into the printer cabinet. Use the CRIND tray mounting screw to align the printer (see [Figure 3](#)).

Note: Do not install the paper roll onto the spool until printer is in the cabinet.

Figure 3: Printer Cabinet

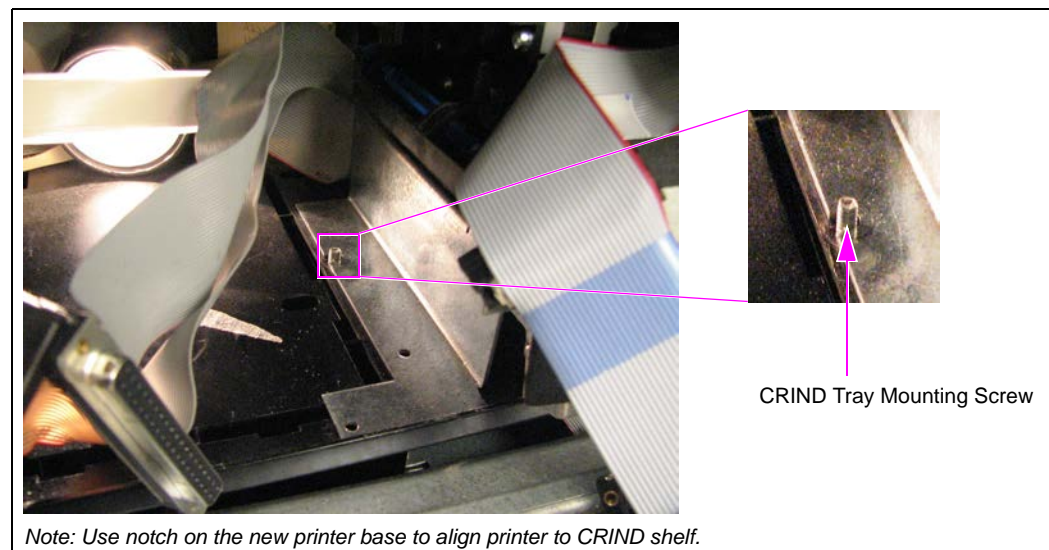

- 2 Tighten the nut on the CRIND tray mounting screw. Using the screw and nuts provided in the kit, secure the printer to the shelf. Ensure that the printer lines up correctly to the slot in the door before tightening hardware.
- 3 Cables are preattached to printer head; verify that the cables are securely latched. Use the small cable clamp on the printer chute to route cables away from printer motor and gears.

Figure 4: Routing Cables Using Cable Clamp

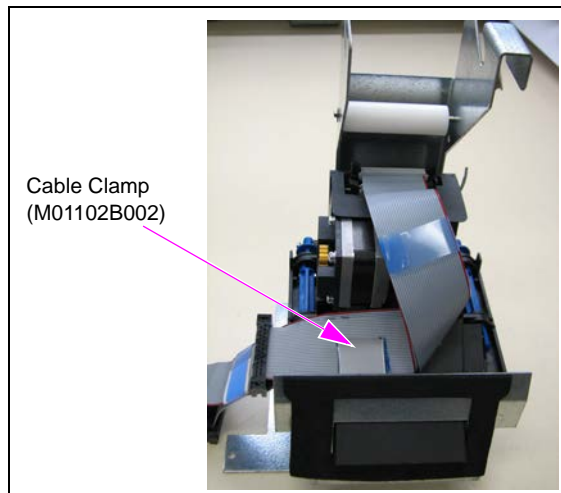

- 4 Plug the two new printer cables to original CRIND cables.
- 5 Use the Flat Cable Mounting Clamp (Q13459-01) to route the cables to the printer. Keep clear of printer motor and gears. Allow sufficient cable length to lift printer module.
- 6 Repower unit once all cables have been plugged.
- 7 Lift the printer head forward to insert paper and perform a printer test for proper operation.

IMPORTANT INFORMATION

The new printer is compatible with printers previously used in The Advantage Series, a CRIND Basic Input/Output System (BIOS) change is not necessary.

Installing the Printer Replacement Kit in The Advantage series unit is now complete.

The Advantage® Series, CRIND®, Encore®, Gilbarco®, Legacy®, and MPD® are registered trademarks of Gilbarco Inc. GOLDSM is a service mark of Gilbarco Inc. Hengstler® is a registered trademark of Danaher Corporation.