

DESCRIPTIVE SYSTEM DOCUMENT FOR CERTIFICATE NUMBER IECEX ULD 08.0002X

REV	DESCRIPTION	BY	DATE	ECO
A	INITIAL RELEASE	TB	2011/07/14	CN-03184
B	TEMPERATURE WAS 40°C	TB	2012/07/14	CN-05085
C	ADDED MAG PLUS1 CERTIFICATION NO.:	TB	2012/07/26	CN-05345

NON-HAZARDOUS AREA

ASSOCIATED APPARATUS

AMBIENT TEMPERATURE RANGE

$$0^{\circ}\text{C} \leq T_a \leq 50^{\circ}\text{C}$$

[Ex ia Ga] IIA

8601 SERIES CONSOLES

HAZARDOUS AREA

INTRINSICALLY SAFE (I.S.) APPARATUS

AMBIENT TEMPERATURE RANGE

(UNLESS NOTED) (C)

$$-40^{\circ}\text{C} \leq T_a \leq 60^{\circ}\text{C}$$

Ex ia IIA T4 Ga

8601 CONSOLE
CERTIFICATE NO.:
IECEX UL 11.0049X

SEE NOTE 7

AC NEUTRAL
(OR +5 VDC)

AC LINE
(OR +24 VDC)

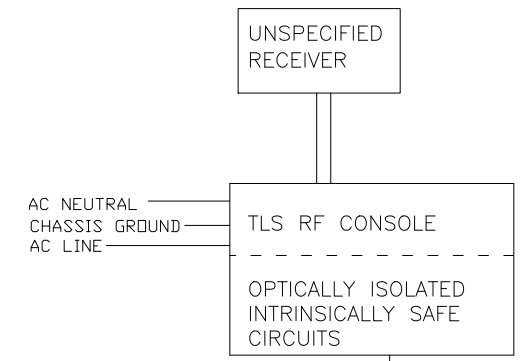
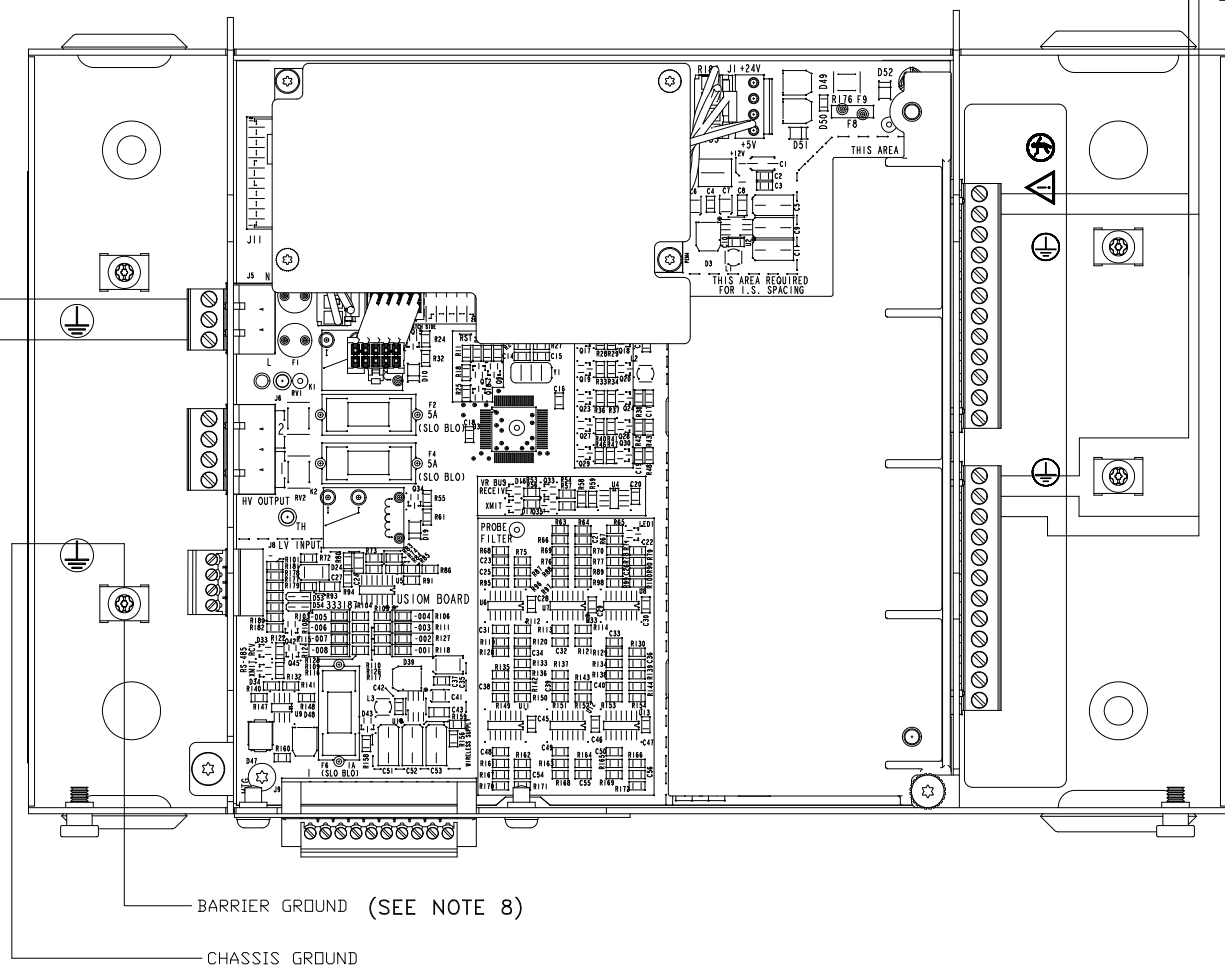

SEE NOTE 5

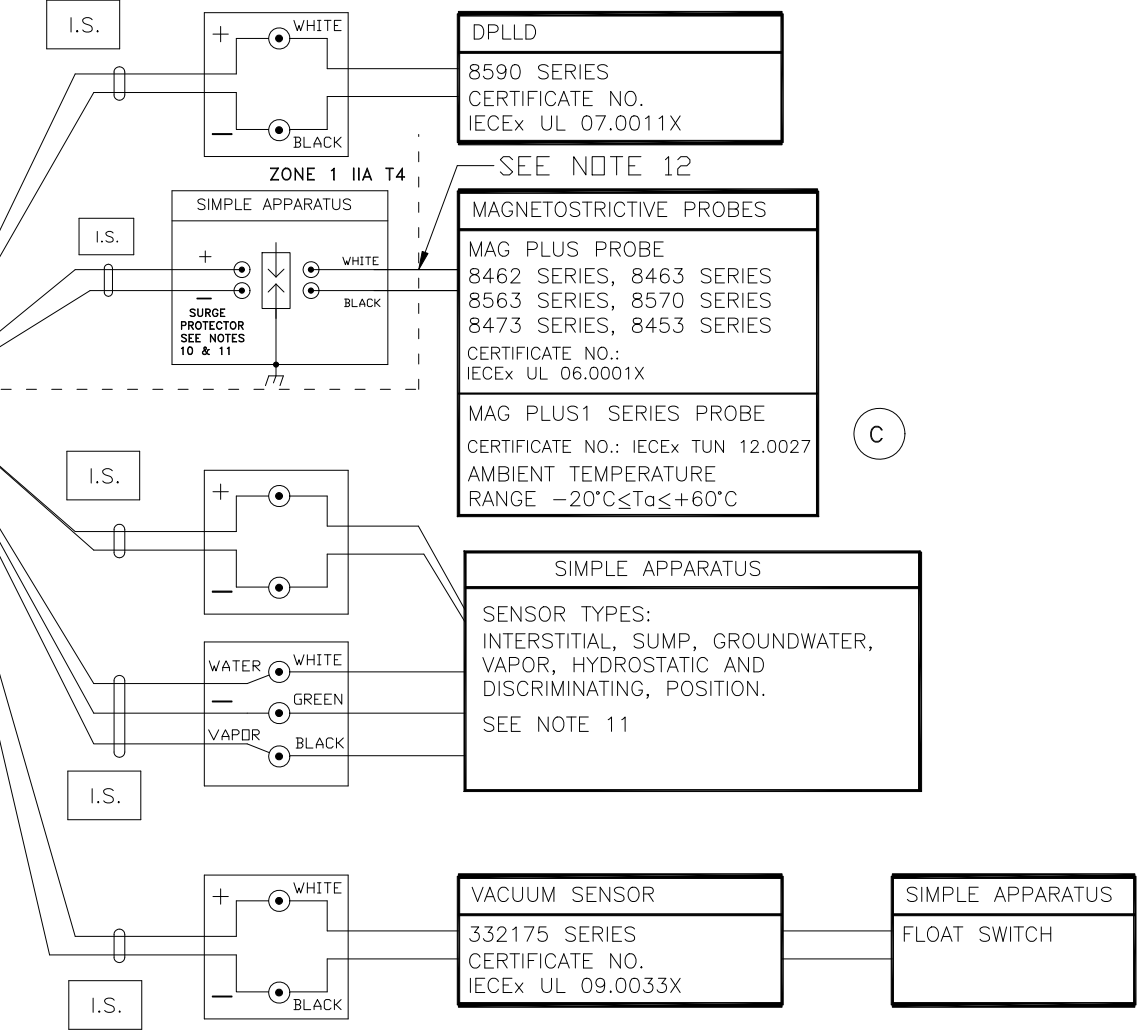
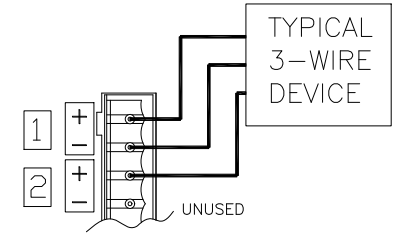
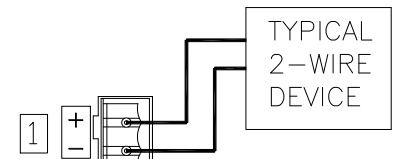

SEE SHEET 2 FOR NOTES

Certified Product
No changes permitted
without reference to the
"Notified Body (NB)"

DO NOT SCALE DRAWING				
DESIGNER	NAME	DATE	NEXT GRP.	
T. BREEN	T. BREEN	2011/07/14	ASSEMBLY	
B. ANDREW	B. ANDREW	2011/07/14	FORM NO	8601
MATERIAL		SIMSBURY, CONNECTICUT 06070 U.S.A.		
NOTICE - THIS DOCUMENT IS THE PROPERTY OF THE VEEDER-ROOT COMPANY AND IS NOT TO BE DISCLOSED, REPRODUCED IN WHOLE OR IN PART, OR USED FOR MANUFACTURE BY ANYONE WITHOUT VEEDER-ROOT'S WRITTEN CONSENT.				
REFERENCE MFG. SPEC. VRS 81005 WHERE IT IS APPLICABLE		DESCRIPTIVE SYS DOCUMENT IECEX TLS4/8601		
UNSPECIFIED TOLERANCES +/- 0.005	SIZE D	DRAWING NUMBER 331940-117	REV. C	STATUS REL
SCALE NONE		SHEET 1 OF 2		

NOTES:

1. THE TOTAL ALLOWABLE CABLE LENGTH USED TO CONNECT ALL OF THE I.S. DEVICES TO THE ASSOCIATED APPARATUS IS 7,315 METERS OR 24,000 FEET.
2. EACH CABLE (OR WIRING) USED TO CONNECT I.S. DEVICES TO THE CONSOLE MUST NOT EXCEED A CAPACITANCE OF 328 pf/METER OR 100 pf/FOOT.
3. THE TOTAL CABLE CAPACITANCE, COMBINING ALL OF THE CABLE USED TO CONNECT THE INTRINSICALLY SAFE DEVICES TO THE ASSOCIATED APPARATUS, MUST NOT EXCEED 5,0 μ F.
4. EACH CABLE MUST NOT EXCEED AN INDUCTANCE OF 0,656 μ H/METER OR 0,2 μ H/FOOT.
5. THE L/R RATIO OF THE CABLE MUST NOT EXCEED 200 μ H/OHM.
6. FOR EACH 8601 CONSOLE INSTALLED THE MAXIMUM NUMBER OF I.S. DEVICES CONNECTED TO THE ASSOCIATED APPARATUS IS 12.
7. NON-HAZARDOUS ASSOCIATED APPARATUS IS AS SHOWN AND MUST NOT BE SUPPLIED FROM OR CONTAIN, UNDER NORMAL OR ABNORMAL CONDITIONS, A SOURCE OF POTENTIAL WITH RESPECT TO EARTH IN EXCESS OF 250V RMS OR 250V dc, $U_m = 250V$.
8. CONNECT THE BARRIER GROUND TO THE EARTH GROUND BUS AT THE POWER DISTRIBUTION PANEL WITH A 4 sq mm (10 AWG) (OR LARGER) CONDUCTOR. GROUNDING MUST COMPLY WITH IEC 60079-0, CLAUSE 15.4.
9. THIS SYMBOL, \odot , DENOTES A FIELD WIRING CONNECTION INSIDE A WEATHERPROOF JUNCTION BOX.
10. A RISK ANALYSIS MUST BE PERFORMED TO DETERMINE IF THE INSTALLATION LOCATION IS SUSCEPTIBLE TO LIGHTNING OR OTHER SURGES. IF NECESSARY, ADD PROTECTION AGAINST LIGHTNING AND OTHER ELECTRICAL SURGES IN ACCORDANCE WITH IEC 60079-25, SECTION 10. IF REQUIRED, INSTALL A SURGE PROTECTOR IN ZONE 1 AS CLOSE AS POSSIBLE TO THE BOUNDARY WITH ZONE 0. THE SITE PREPARATION GUIDE, MANUAL NO. 577013-578, PROVIDES ADDITIONAL DETAILS ABOUT RISK ASSESSMENT.
11. IT IS THE RESPONSIBILITY OF THE INSTALLER TO DETERMINE COMPLIANCE OF SIMPLE APPARATUS. SIMPLE APPARATUS USED WITH THIS SYSTEM MUST CONFORM TO THE FOLLOWING REQUIREMENTS:
 - A) CONSTRUCTED OF PASSIVE COMPONENTS ONLY, FOR EXAMPLE, SWITCHES, JUNCTION BOXES AND RESISTORS.
 - B) CONSTRUCTED WITHOUT ANY SOURCES OF STORED ENERGY SUCH AS BATTERIES, CAPACITORS AND INDUCTORS.
 - C) CONSTRUCTED WITHOUT SOURCES OF GENERATED ENERGY THAT PRODUCE MORE THAN 1.5V, AND 25mW OR SOURCES THAT CONTAIN A MEANS OF INCREASING THE VOLTAGE.
 - D) IF CONSTRUCTED WITH A METALLIC HOUSING THE SIMPLE APPARATUS SHALL BE CAPABLE OF WITHSTANDING THE TEST VOLTAGE TO EARTH IN ACCORDANCE WITH IEC 60079-11, CLAUSE 6.3.12 AND ITS TERMINALS MUST CONFORM TO IEC 60079-11, CLAUSE 6.2.1.
 - E) NONMETALIC ENCLOSURES AND ENCLOSURES OF LIGHT METALS MUST COMPLY WITH IEC 60079-0 SECTIONS 7 & 8 AND IEC 60079-26 CLAUSE 4.3.3.
 - F) BASED ON THE AVAILABLE POWER WITHIN THE SYSTEM, SIMPLE APPARATUS THAT HAVE ELECTRICAL COMPONENTS THAT EXCEED 20mm² IN TOTAL SURFACE AREA, MAY BE ASSESSED AS HAVING A T4 TEMPERATURE CODE, AT THE SPECIFIED AMBIENT TEMPERATURE RANGE OF -40°C \leq Ta \leq +60°C. OTHER TYPES OF SIMPLE APPARATUS MUST BE ASSESSED IN ACCORDANCE WITH IEC 60079-11, SECTION 6.2.
12. CABLE GLAND MUST BE A SUITABLE PROCESS CONNECTION IN ACCORDANCE WITH IEC 60079-26.
13. SPECIAL CONDITIONS FOR SAFE USE, AS DEFINED IN THE CERTIFICATE OF CONFORMITY AND THE SITE PREPARATION GUIDE, MANUAL NO. 577013-578, MUST BE TAKEN INTO ACCOUNT.
14. THIS SYSTEM DESCRIPTIVE DOCUMENT DESCRIBES THE INTRINSICALLY SAFE EQUIPMENT AND ASSOCIATED APPARATUS THAT TOGETHER FORM AN INTRINSICALLY SAFE SYSTEM.
15. A TLS4/8601 CONSOLE CANNOT BE CONNECTED IN PARALLEL WITH ANOTHER TLS4/8601 OR ANY OTHER ASSOCIATED APPARATUS. TLS4/8601 CONSOLES MUST BE INSTALLED IN AN INDOOR, NON-HAZARDOUS AREA.

STANDARDS:

[Ex ia Ga], GROUP IIA T4

IEC 60079-0	ELECTRICAL APPARATUS FOR POTENTIALLY EXPLOSIVE ATMOSPHERES-PART 0: GENERAL REQUIREMENTS
IEC 60079-11	ELECTRICAL APPARATUS FOR POTENTIALLY EXPLOSIVE ATMOSPHERES-PART 11: INTRINSIC SAFETY "I"
IEC 60079-25	ELECTRICAL APPARATUS FOR EXPLOSIVE GAS ATMOSPHERES-PART 25: INTRINSICALLY SAFE SYSTEMS
IEC 60079-26	ELECTRICAL APPARATUS FOR EXPLOSIVE GAS ATMOSPHERES - PART 26: CONSTRUCTION, TEST AND MARKING OF GROUP II ZONE 0 ELECTRICAL APPARATUS

		SIMSBURY, CONNECTICUT 06070 U.S.A.	
NOTICE - THIS DOCUMENT IS THE PROPERTY OF THE VEEDER-ROOT COMPANY AND IS NOT TO BE DISCLOSED, REPRODUCED IN WHOLE OR IN PART, OR USED FOR MANUFACTURE BY ANYONE WITHOUT VEEDER-ROOT'S WRITTEN CONSENT.			
DESCRIPTIVE SYS DOCUMENT IECEX TLS4 / 8601			
SIZE	DRAWING NUMBER	REV.	STATUS
D	331940-117	C	REL
SCALE	NONE	SHEET	2 OF 2