

# Motor/Pump Monitor Module

## Installation Guide

# Notice

---

Veeder-Root makes no warranty of any kind with regard to this publication, including, but not limited to, the implied warranties of merchantability and fitness for a particular purpose.

Veeder-Root shall not be liable for errors contained herein or for incidental or consequential damages in connection with the furnishing, performance, or use of this publication.

Veeder-Root reserves the right to change system options or features, or the information contained in this publication.

This publication contains proprietary information which is protected by copyright. All rights reserved. No part of this publication may be photocopied, reproduced, or translated to another language without the prior written consent of Veeder-Root.

## **DAMAGE CLAIMS / LOST EQUIPMENT**

Thoroughly examine all components and units as soon as they are received. If any cartons are damaged or missing, write a complete and detailed description of the damage or shortage on the face of the freight bill. The carrier's agent must verify the inspection and sign the description. Refuse only the damaged product, not the entire shipment.

## **VEEDER-ROOT'S PREFERRED CARRIER**

1. Contact VR Customer Service at 800-873-3313 with the specific part numbers and quantities that were missing or received damaged.
2. Fax signed Bill of Lading (BOL) to VR Customer Service at 800-234-5350.
3. VR will file the claim with the carrier and replace the damaged/missing product at no charge to the customer. Customer Service will work with production facility to have the replacement product shipped as soon as possible.

## **CUSTOMER'S PREFERRED CARRIER**

1. It is the customer's responsibility to file a claim with their carrier.
2. Customer may submit a replacement purchase order. Customer is responsible for all charges and freight associated with replacement order. Customer Service will work with production facility to have the replacement product shipped as soon as possible.
3. If "lost" equipment is delivered at a later date and is not needed, VR will allow a Return to Stock without a restocking fee.
4. VR will NOT be responsible for any compensation when a customer chooses their own carrier.

## **RETURN SHIPPING**

For the parts return procedure, please follow the appropriate instructions in the "General Returned Goods Policy" and "Parts Return" pages in the "Policies and Literature" section of the Veeder-Root **North American Environmental Products** price list.

## **WARRANTY**

**Please see next page, iii.**

# Warranty

---

## **TLS-350R, TLS-350 PLUS, TLS-350J AND TLS-300I/C, AND TLS-2 MONITORING SYSTEMS.**

We warrant that this product shall be free from defects in material and workmanship for a period of one (1) year from the date of installation or twenty-four (24 months) from the date of invoice, whichever occurs first. During the warranty period, we or our representative will repair or replace the product, if determined by us to be defective, at the location where the product is in use and at no charge to the purchaser. **LAMPS AND FUSES ARE NOT COVERED UNDER WARRANTY.**

We shall not be responsible for any expenses incurred by the user.

This warranty applies only when the product is installed in accordance with Veeder-Root's specifications, and a Warranty Registration and Checkout Form has been filed with Veeder-Root by an authorized Veeder-Root Distributor. This warranty will not apply to any product which has been subjected to misuse, negligence, accidents, systems that are misapplied or are not installed per Veeder-Root specifications, modified or repaired by unauthorized persons, or damage related to acts of God.

If "Warranty" is purchased as part of the Fuel Management Service, Veeder-Root will maintain the equipment for the life of the contract in accordance with the written warranty provided with the equipment. A Veeder-Root Fuel Management Services Contractor shall have free site access during Customer's regular working hours to work on the equipment. Veeder-Root has no obligation to monitor federal, state or local laws, or modify the equipment based on developments or changes in such laws.

## **ILS-350 MONITORING SYSTEMS**

We warrant that this product shall be free from defects in material and workmanship for a period of one (1) year from the date of installation or twenty-four (24) months from the date of invoice, whichever occurs first. During the first ninety (90) days, we or our representative will repair or replace the product, if determined by us to be defective, at the location where the product is in use and at no charge to the purchaser. After the first ninety (90) days of the warranty period, we will repair or replace the product if it is returned to us, transportation prepaid, within the warranty period and is determined by us to be defective. We will not be responsible for any shipping expenses incurred by the user. **LAMPS AND FUSES ARE NOT COVERED UNDER WARRANTY.**

This warranty applies only when the product is installed in accordance with Veeder-Root's specifications, and a Warranty Registration and Checkout Form has been filed with Veeder-Root by an Authorized Veeder-Root Distributor. This warranty will not apply to any product which has been subjected to misuse, negligence, accidents, systems that are misapplied or are not installed per Veeder-Root specifications, modified or repaired by unauthorized persons, or damage related to acts of God.

## **MODULES, KITS, OTHER COMPONENTS (PARTS PURCHASED SEPARATE OF A COMPLETE CONSOLE).**

We warrant that this product shall be free from defects in material and workmanship for a period of fifteen (15) months from date of invoice. We will repair or replace the product if the product is returned to us; transportation prepaid, within the warranty period, and is determined by us to be defective. This warranty will not apply to any product which has been subjected to misuse, negligence, accidents, systems that are misapplied or are not installed per Veeder-Root specifications, modified or repaired by unauthorized persons, or damage related to acts of God.

We shall not be responsible for any expenses incurred by the user.

**Introduction**

General ..... 1  
Related Manuals ..... 1  
Contractor Certification Requirements ..... 1  
Safety Precautions ..... 2  
Warnings and Important Notes ..... 2

**Installation**

Module/Connector Positions ..... 3  
    Module Position ..... 3  
    Connector Position ..... 3  
Module Installation ..... 3  
Module Wiring ..... 4  
Module Setup ..... 4

**Figures**

Figure 1. Power Bay in TLS Console ..... 3  
Figure 2. Motor/Pump Monitor module wiring diagram -  
Red Jacket relay control box ..... 5  
Figure 3. Motor/Pump Monitor module wiring diagram -  
non-Red Jacket relay control box ..... 6  
Figure 4. Motor/Pump Monitor module wiring diagram -  
Vapor Recovery Systems ..... 7

# Introduction

## General

---

This manual contains procedures for the installation or replacement of the following:

- Veeder-Root Motor/Pump Monitor module (P/N 332643-001)

The above module is for TLS 350 Series consoles having version 27 or higher software. This manual assumes all preliminary site preparation is completed, and that field wiring from the pump relay box to the TLS console is in place.

If site preparation is necessary, refer to the TLS-3XX Site Preparation and Installation manual, or contact your Veeder-Root representative for assistance.

## Related Manuals

---

576013-879      TLS-3XX Site Prep and Installation Manual

576013-623      TLS-3XX System Setup Manual

## Contractor Certification Requirements

---

Veeder-Root requires the following minimum training certifications for contractors who will install and setup the equipment discussed in this manual:







**Level 1**      Contractors holding valid Level 1 Certification are approved to perform wiring and conduit routing, equipment mounting, probe and sensor installation, tank and line preparation, and line leak detector installation.

**Level 2/3**      Contractors holding valid Level 2 or 3 Certifications are approved to perform installation checkout, startup, programming and operations training, troubleshooting and servicing for all Veeder-Root Tank Monitoring Systems, including Line Leak Detection and associated accessories.





**Warranty Registrations** may only be submitted by selected distributors.

## Safety Precautions

The following safety symbols are used throughout this manual to alert you to important safety hazards and precautions.

 <p><b>EXPLOSIVE</b> Fuels and their vapors are extremely explosive if ignited.</p>	 <p><b>FLAMMABLE</b> Fuels and their vapors are extremely flammable.</p>
 <p><b>ELECTRICITY</b> High voltage exists in, and is supplied to, the device. A potential shock hazard exists.</p>	 <p><b>TURN POWER OFF</b> Live power to a device creates a potential shock hazard. Turn Off power to the device and associated accessories when servicing the unit.</p>
 <p><b>WARNING</b> Heed the adjacent instructions to avoid equipment damage or personal injury.</p>	 <p><b>READ ALL RELATED MANUALS</b> Knowledge of all related procedures before you begin work is important. Read and understand all manuals thoroughly. If you do not understand a procedure, ask someone who does.</p>

## Warnings and Important Notes

<b>⚠ WARNING</b>	
   	<p><b>You are working with a device in which potentially lethal voltages may be present. This product is to be installed in systems operating near locations where highly combustible fuels or vapors may be present.</b></p> <p><b>Fire or explosion resulting in serious injury or death could result if the equipment is improperly installed or modified. Serious contamination of the environment may also occur.</b></p> <ol style="list-style-type: none"> <li><b>1. Read and follow all instructions in this manual, including all safety warnings.</b></li> <li><b>2. Turn off and lock out power to the pump before installing this module.</b></li> <li><b>3. To be installed in accordance with the National Electrical Code, NFPA 70 and the Automotive And Marine Service Station Code, NFPA.</b></li> <li><b>4. Do not alter or modify any component or substitute components in this kit.</b></li> <li><b>5. Do not use this component for other systems aside from the TLS console. Install only as described in this manual or you will void all warranties connected with this product.</b></li> </ol>

# Installation

## Module/Connector Positions

Figure 1 shows the Power Bay slots of the TLS console in which Motor/Pump Monitor modules can be installed.

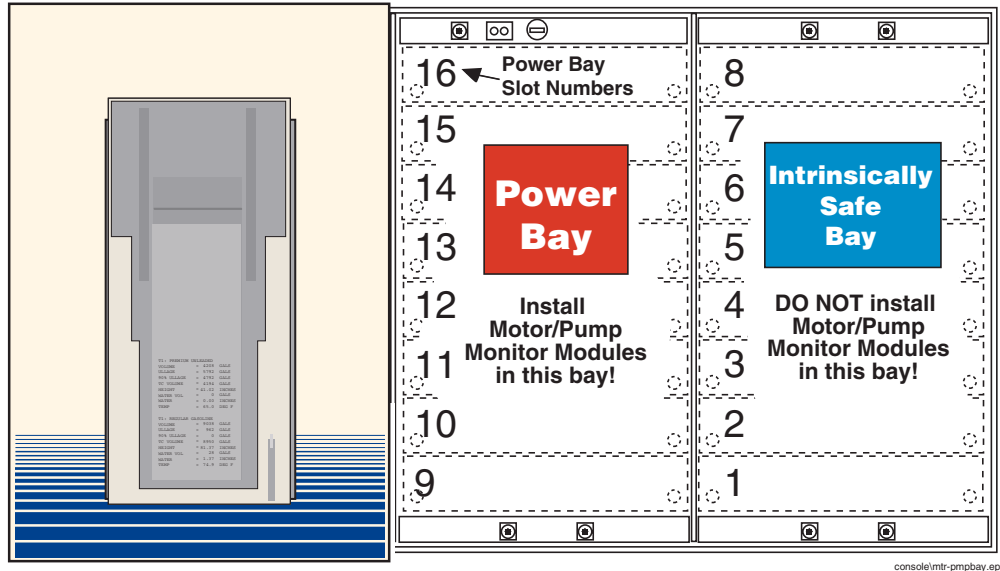

Figure 1. Power Bay in TLS Console

### MODULE POSITION

- Record on the circuit directory (on the inside front panel of the TLS console) the type of module you are installing in this slot.
- Once a particular type of module has been installed in that slot, the system will always look for that type of module in that slot.

### CONNECTOR POSITION

- Identify all connectors according to their slot location using the self-adhesive numbering labels supplied with each module.
- Once a device has been wired to certain terminals on the connector and the system has been programmed, terminal position may not be changed without reprogramming the system.

### Module Installation

For additional information regarding the below steps, refer to the Veeder-Root TLS-3XX Site Preparation and Installation manual. Read and follow all instructions carefully.

1. To retain current programming, open the left-hand door and check that the battery backup switch (SW1) is set to "ON". To avoid electrical shock or damage to components when accessing the switch, avoid touching any circuit components with your hand or any conductive tool or jewelry.
2. Turn TLS console POWER OFF before installing the module.

3. Open the right-hand door of the TLS console. While working in the Power Bay of the TLS console, avoid shorting high voltage across any component or module in the adjacent intrinsically safe bay. This could result in an explosion near the sensor.
4. Remove a blank cover plate from any unused slot in the Power Bay compartment.
5. Slide the new module into the empty slot until its rear board connector engages the connector in the TLS console. Gently push in on the module until the connector is completely seated. Do not apply excessive force when installing the module. Push the two snap fasteners on the front panel of the module until they snap in.
6. Be sure all of remaining unused slots in the Power Bay have blank plates installed.



If you are installing these modules in a system that has already been programmed, you **CANNOT CHANGE** the position of existing modules and/or connectors without reprogramming the entire system. If any connectors are removed during installation, **BE SURE** they are reconnected to their original modules.

<b>WARNING</b>	
	<p><b>You are working with a device in which potentially lethal voltages may be present.</b></p> <p><b>If high voltage is shorted across any barrier terminal, explosion and fire could result.</b></p> <p><b>Be sure AC POWER to the TLS console is OFF before opening the front panel and installing or wiring any module.</b></p>

Be sure to record on the circuit directory the type of module and the name or location of each device wired to the connector.



Once external devices have been connected and the system has been programmed, module, connector and wiring positions cannot be changed without re-programming the system.

Improper system operation will result if any one of these positions are changed without re-programming.

Refer to the appropriate module wiring diagram below and connect the wires from each external device to the appropriate terminals on the module connector.



Module wiring is connected to devices located in the non-hazardous area and it must be in accordance with the National Electrical Code (NFPA 70) and the Automotive and Marine Service Station Code (NFPA 30A).

## Module Wiring

---

Figure 2 shows an example wiring diagram with Red Jacket pumps, Figure 3 contains a wiring diagram for non-Red Jacket relay control boxes, and Figure 4 illustrates an example wiring diagram with vapor recovery systems.

## Module Setup

---

Refer to the TLS-3XX System Setup manual to configure the Motor/Pump Monitor module.



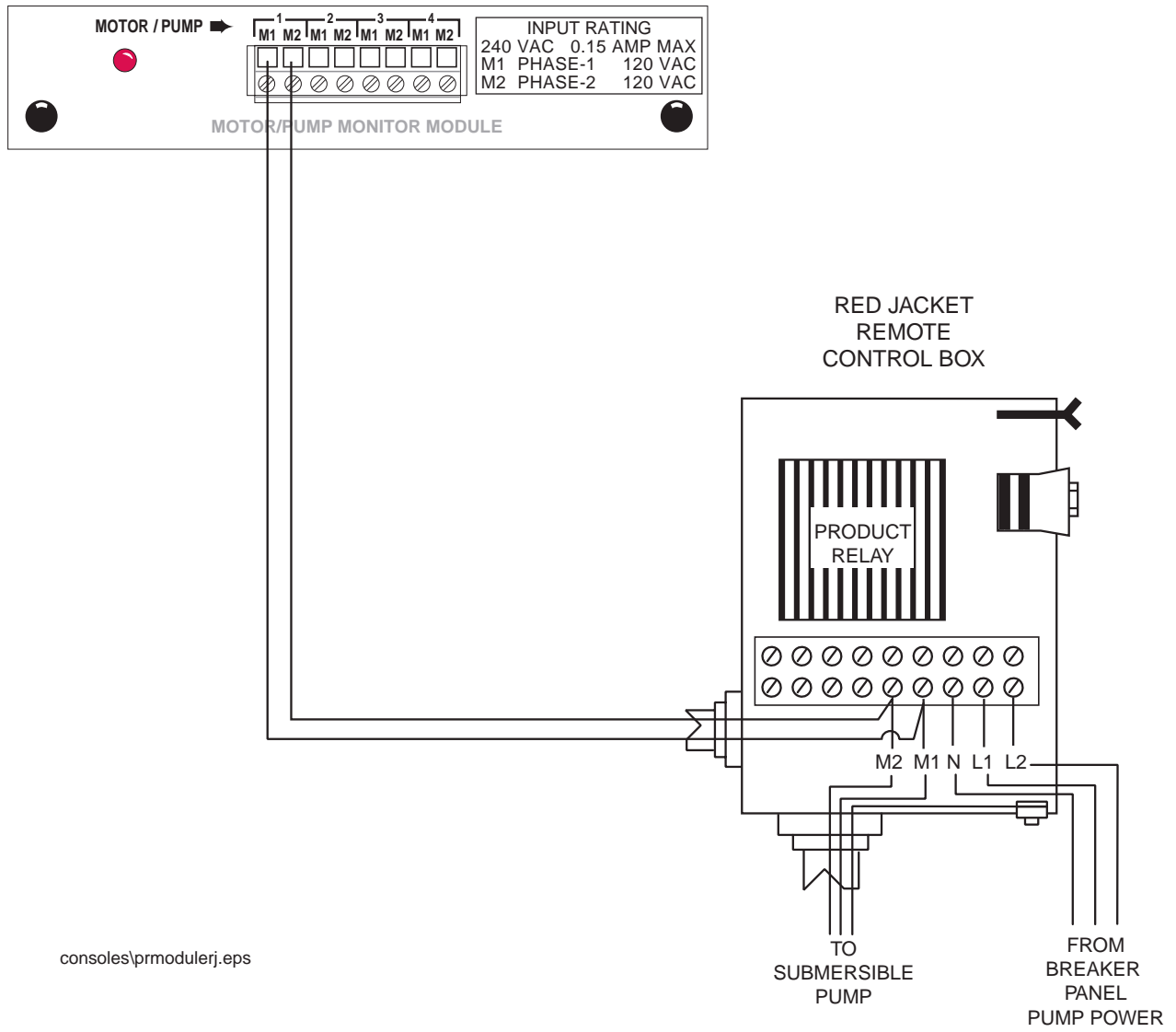

Figure 2. Motor/Pump Monitor module wiring diagram - Red Jacket relay control box

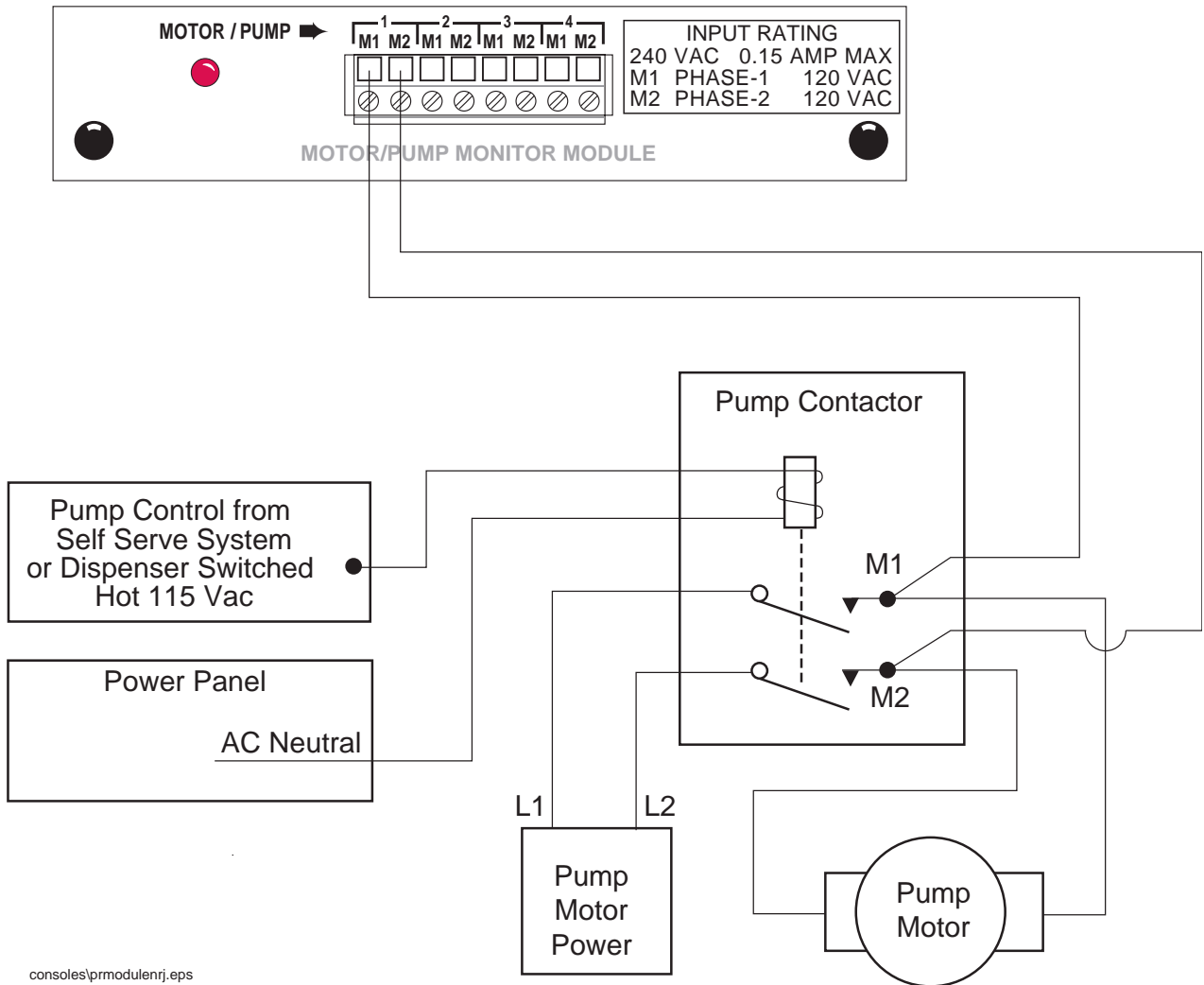

Figure 3. Motor/Pump Monitor module wiring diagram - non-Red Jacket relay control box

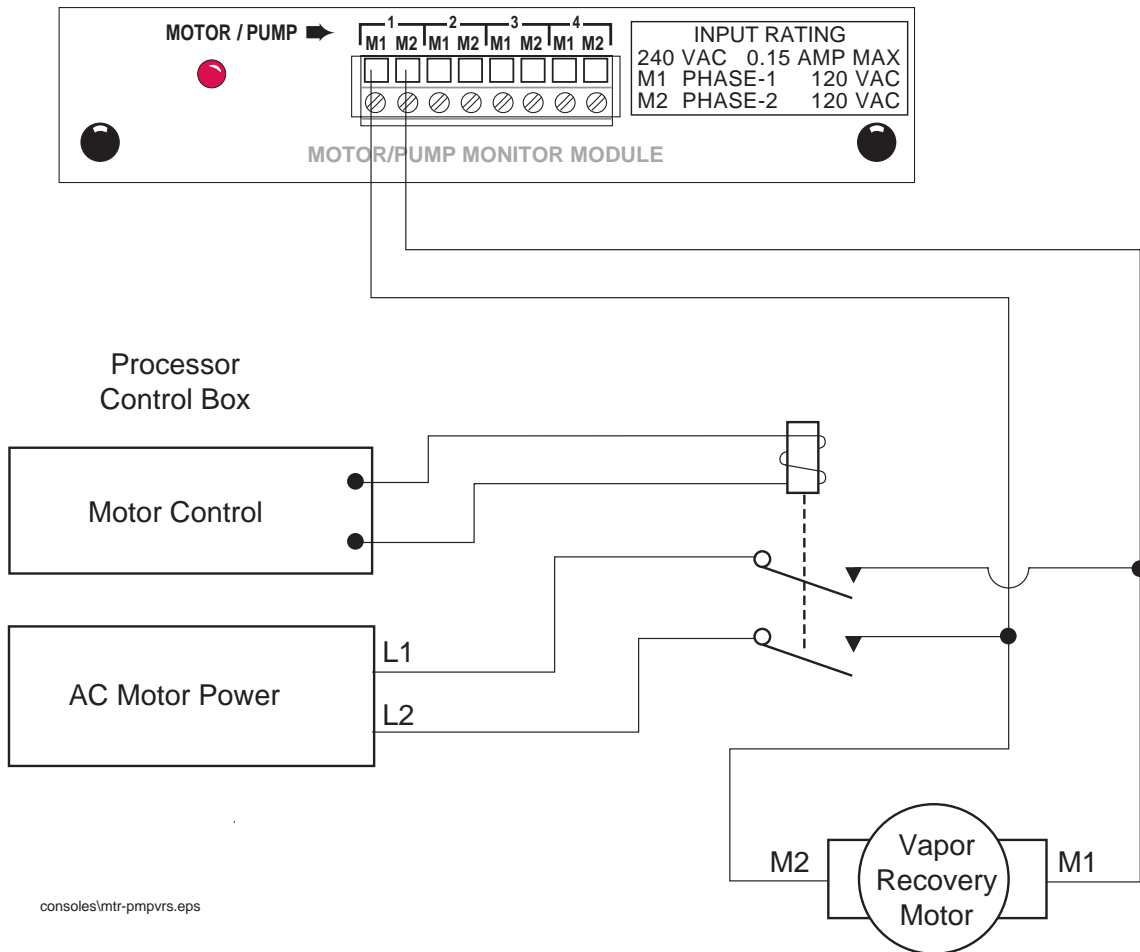

Figure 4. Motor/Pump Monitor module wiring diagram - Vapor Recovery Systems

