



INSTALLATION INSTRUCTIONS

4" Petroleum Pump Wiring Diagram

The following defined terms are used throughout this literature to bring attention to the presence of hazards of various risk levels, or to important information concerning the life of the product.

WARNING	indicates presence of a hazard which <i>can</i> cause <i>severe</i> personal injury, death or substantial property damage if ignored.	CAUTION	indicates presence of a hazard which <i>will</i> or <i>can</i> cause <i>minor</i> personal injury, death or substantial property damage if ignored.
DANGER	indicates presence of a hazard which <i>will</i> cause <i>severe</i> personal injury, death or substantial property damage if ignored.	NOTICE	indicates special instructions on installations, operation, or maintenance which are important but not related to personal injury hazards.

230 VOLT REMOTE CONTROL BOX WITHOUT CAPACITOR

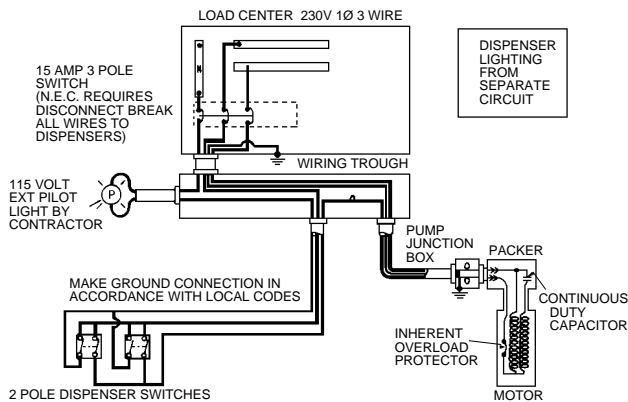

Suggested wiring diagram WITHOUT optional control box. Combination of 1 pole dispenser switches or external pilot light requires special instructions – consult factory.

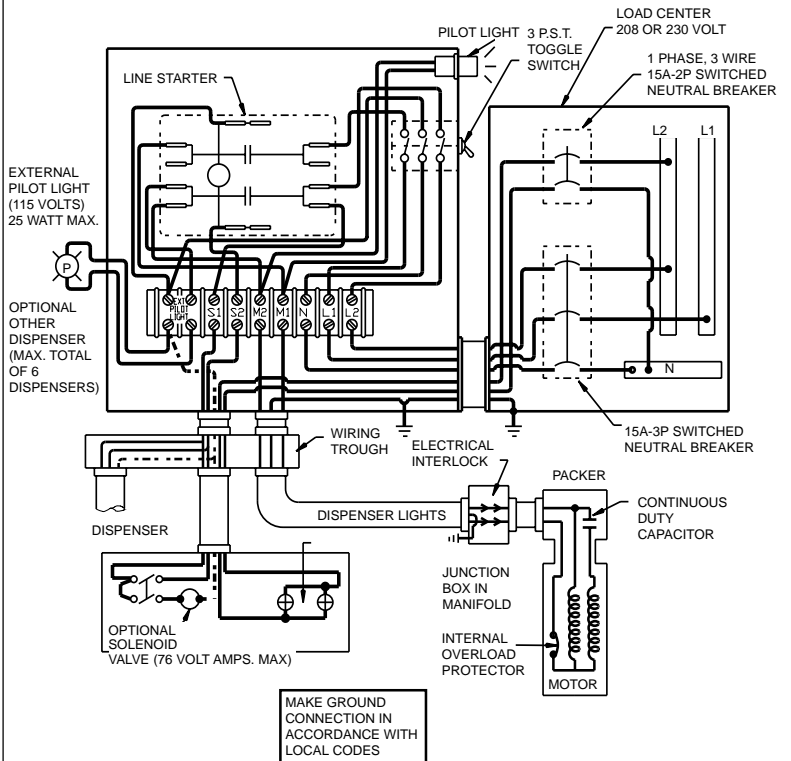

ELECTRICAL CONNECTOR

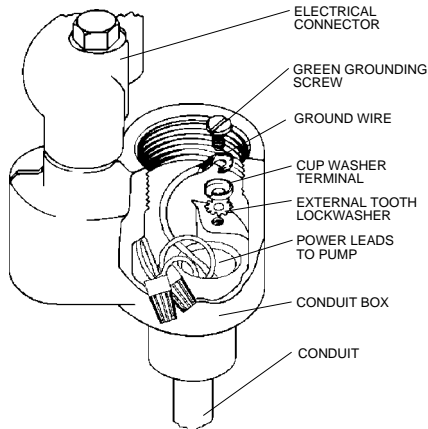

230 VOLT REMOTE CONTROL BOX WITH CAPACITOR

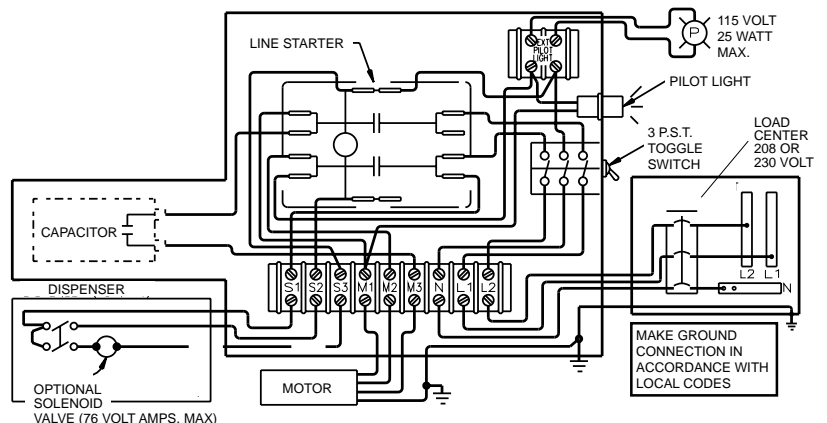

4" PETROLEUM PUMP WIRING INSTRUCTIONS



DANGER ALWAYS DISCONNECT and LOCK or TAG OUT the power before starting to service the pump.

1. Connect electrical conduit through approved fittings to junction box.



2. Remove cover from junction box. Provision has been made for 2 wire, or 3 wire and optional ground. Pull wires from power supply through junction box.



3. Connect wires from power supply to wire in the junction box. Make waterproof splice. Replace cover using waterproof thread sealant. Install optional ground wire as shown if applicable.

REPLACING THE PUMP MOTOR ASSEMBLY



1. Remove the four screws holding motor to the head casting.



2. Rock unit while pulling away from discharge head until free.



3. TO RE-ASSEMBLE: Replace gasket, align dowel pin, draw in place with cap screws.

REPLACING THE CAPACITOR INSTALLED IN PACKER



DANGER

1. ALWAYS DISCONNECT and LOCK or TAG OUT the power before starting to service the pump. Remove capacitor cover.



2. Remove retaining clip. Pull quick-connectors.

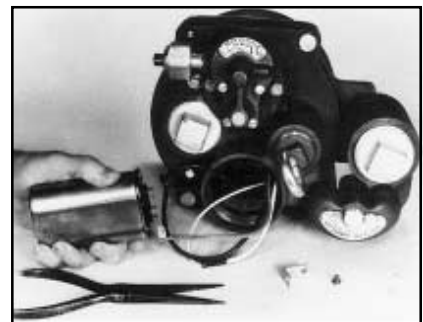

3. Remove capacitor.
TO REPLACE: Reverse these steps.



by  VEEDER-ROOT

125 Powder Forest Drive • Simsbury, CT 06070
Tel: (860) 651-2700 • Fax: (860) 651-2719

017-558-1 Rev. E