



Trapper Intake Screen Field Installation Instructions

PATENT No. 5,383,769

The following defined terms are used throughout this literature to bring attention to the presence of hazards of various risk levels, or to important information concerning the life of the product.

DANGER indicates presence of a hazard which *will* cause *severe* personal injury, death or substantial property damage if ignored.

CAUTION indicates presence of a hazard which *will* or *can* cause *minor* personal injury, death or substantial property damage if ignored.

WARNING indicates presence of a hazard which *can* cause *severe* personal injury, death or substantial property damage if ignored.

NOTICE indicates special instructions on installations, operation, or maintenance which are important but not related to personal injury hazards.

WARNING

The addition of the Trapper intake screen kit increases the overall length of the pump by 3.28 inches. Be certain that the clearance is sufficient (recommended 4" minimum) to avoid tank and/or pump damage.

NOTICE

If the pump is currently installed, see the instructions for the removal of the pump on page two.

STEP 1: Remove inlet cap from the center of the pump intake at the end of the UMP Unit. (See Figure 1)

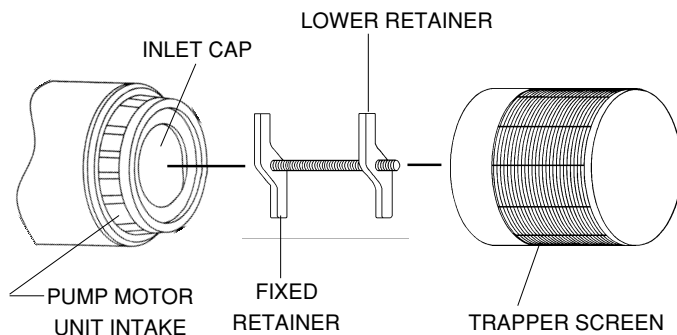

Figure 1

STEP 2: Position fixed retainer into inlet opening by angling retainer so both ends of it are inside the inlet. (See Figure 2)

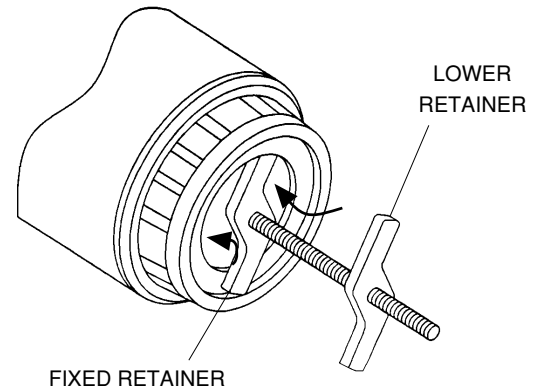

Figure 2

STEP 3: Thread lower retainer up against bottom of inlet and hand tighten.

NOTICE

Rod should be centered on inlet. (See Figure 3)

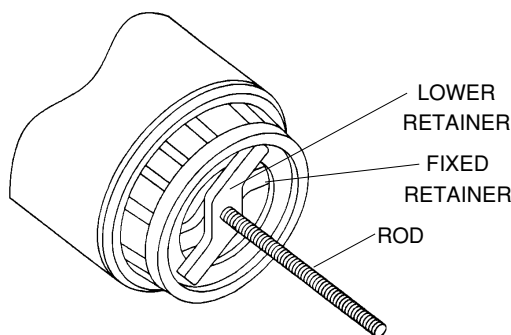

Figure 3

STEP 4: Install the Trapper screen onto the threaded rod and turn until flush against the inlet. (See Figure 4)

CAUTION

Hand tighten only.

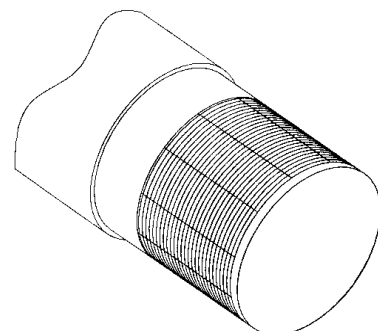

Figure 4

Instructions For Removing The Pumping Unit



DANGER

1. ALWAYS DISCONNECT and LOCK or TAG OUT the power before starting to service the pump.

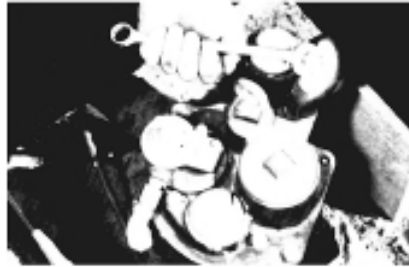

2. Backout bayonet electrical disconnect bolt.

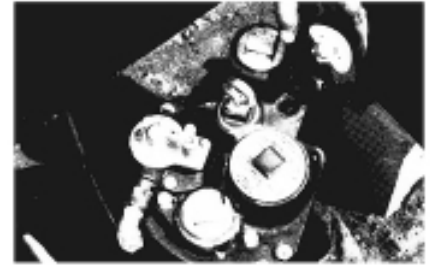

3. Swing electrical connector aside.

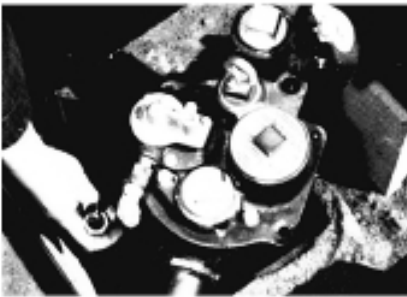

4. IF SYPHON SYSTEM: Disconnect syphon tubing.



5. Remove the two lockdown bolts.



6. Lift unit. Replace unit by reversing these steps.

CAUTION

DO NOT damage the surface above the discharge port. The o-ring, below the leak detector port, seals on this surface.

CAUTION

The Trapper optional intake screen increases the length of the pump/motor unit. This increased length must be considered in field-installed situations to insure proper clearance from the bottom of the tank.

Model Number	Standard and AG				w/ Trapper factory installed		w/ Trapper field installed
	HP	Stages	Length (inches)	Shipping Weight (lbs.)	Length (inches)	Shipping Weight (lbs.)	Length (inches)
UMP33R1 or AGUMP33R1	1/3	2	15 -1/2	30	17-21/32	31	18-5/8
UMP75S1 or AGUMP75S1	3/4	2	17-1/2	32	19-21/32	33	20-5/8
UMP150S1 or AGUMP150S1	1-1/2	2	20-11/16	38	22-27/32	39	23-13/16
X3UMP150S1 or X3AGUMP150S1	1-1/2	3	21-39/64	32	23-49/64	36.5	24-43/64
X5UMP150S1 or X5AGUMP150S1	1-1/2	5	32-1/32	39-1/2	NA	N/A	N/A

For the lengths when the Trapper is installed in the field, add 3-1/8" to the Standard/AG lengths.