

SERIES 7671 PULSE TRANSMITTER

Manual No. 230194, Rev C, April 2025

DESCRIPTION

These instructions are for installation of the Series 7671 Solid State Pulse Transmitter (see Figure 1) designed and manufactured by Veeder-root Company, 2709 Route 764, Duncansville, PA 16635, (814) 695-4476.

When a vertical bar appears adjacent to text or illustrations, information has been added or changed at the last issue date.

These solid state pulse transmitters provide fast and accurate signaling for remote indication totalizing and data monitoring systems. They are cULus listed for gasoline pump computers and applications that require monitoring of output shaft rotation in hazardous locations.

The output can be either dual channel with 50 pulses per revolution per channel or single channel with 100 pulses per revolution. The dual channel pulse trains can be staggered or overlapping. A staggered output allows errors to be detected on either channel or on both concurrently (power loss to pulser). An overlapping (quadrature) output permits the detection of direction of rotation and errors on either channel but not on both concurrently. The single channel devices are used when greater pulse density is desired and error detection is not required.

SPECIFICATIONS

Specifications listed are standard unless otherwise noted. Optional features are available at additional cost.

Recommended Operating Conditions (each channel):

- Power Requirement: 10 to 15 VDC, 50 mA (max.) at 15 VDC
- Output Voltage: Dependent on load. (see Figure 2).
- Switching Times: Rise Time - 2 microseconds maximum with 10 mA resistive load to ground; Fall Time - 4 microseconds maximum.

Rotation: Standard is bidirectional. Optional models available with no-back feature.

Input Shaft Speed: 600 rpm maximum

Torque: 2 Oz-in. maximum (144 g-cm)

Output Pulse: Dual channel at 50 ppr, staggered or overlapping (quadrature). Single channel at 100 ppr (See Figure 3).

Duty Cycle:

- Overlapping/Quadrature: 50% ±10% high/low ratio. Second channel phase displaced by 90° ±18°.
- Staggered: 75% ±5% high/low ratio. Second channel displaced by 180° ±18°.
- Single Channel: 50% ±10% high/low ratio.

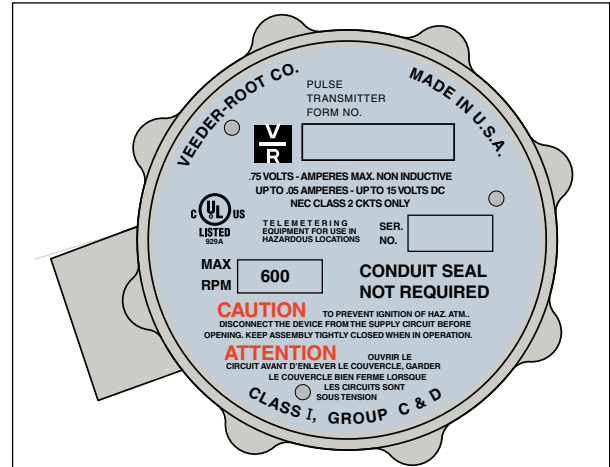

Figure 1. Series 7671 Pulse Transmitter

Circuit Class: For National Electric Code Class 2 Circuits only

Operating Environment: -40° to +82°C (-40° to +180°F)

Storage Environment: -55° to +125°C (-67° to +257 °F)

Shaft: Specify length of either 24.28 or 41.80 mm (0.956 or 1.672 inch). Other lengths available.

Shock: Normal shipping.

Housing: Explosion-proof. For use in hazardous location, Class 1, Group D.

Mounting: Three .250-20 UNC-2B blind tapped holes, spaced 120° apart on a 63.5 mm (2.5 in.) diameter bolt circle.

Leads: 48 in. (120 cm) of 3 or 4 conductors and ground, gas and oil resistant, #18 AWG wire.

NOTICE Consult Veeder-Root on any unusual application, installation, or possible modification of this basic design.

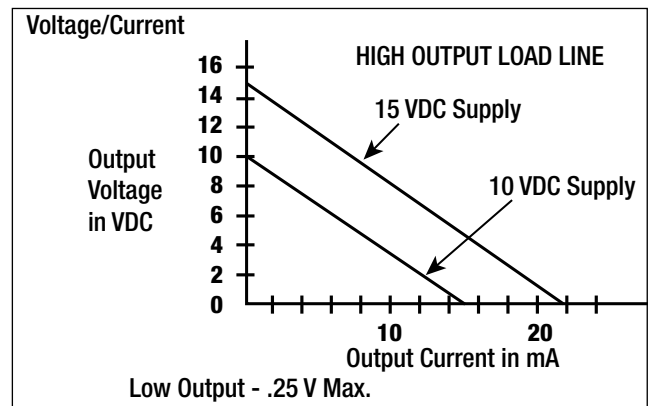

Figure 2. Output Current

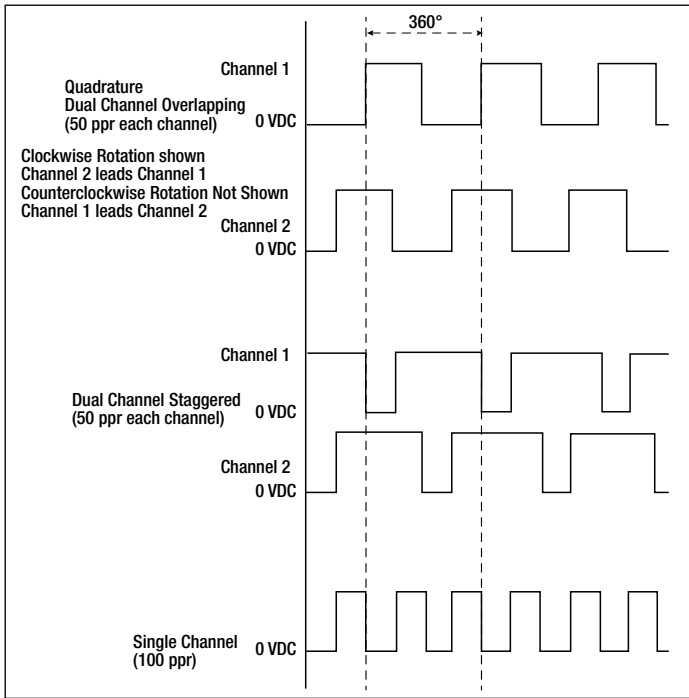

Figure 3. Logic Output Signals

INSTALLATION



WARNING

In installation and use of this product, comply with the National Electrical Code and/or any other applicable safety codes. In addition, disconnect power and take other necessary precautions to prevent personal injury and equipment damage during installation and service.

General

Proper installation is necessary if this pulse transmitter is to provide satisfactory operation. Improper installation will result in damage from any of the following conditions:

1. Connecting reverse supply voltage.
2. Connecting pulser signal output to power supply positive.
3. Exceeding temperature range: -40° to $+82^{\circ}\text{C}$ (-40° to $+180^{\circ}\text{F}$).
4. Operating in excess of 600 rpm.

Conditions 1 and 2 above cause irreversible damage almost instantaneously. Excessive heat causes permanent damage whether or not the unit is in use. Excessive cold prevents the unit from functioning, but it will recover when normal temperature is restored.

Mounting

1. Installation may be made in almost any environment free from severe vibration and extreme temperature.

WARNING

Although this pulse transmitter is UL listed for Class I, Group D location, contact Veeder-Root when considering installation in a questionable location or environment.

2. Three equally spaced holes, 0.250-20 UNC-2B, on the back of the case are provided for mounting (see Figure 4). Brackets and mounting arrangements must be sufficient to maintain alignment and minimize side load on shaft bearings.

NOTICE Do not use conduit for support.

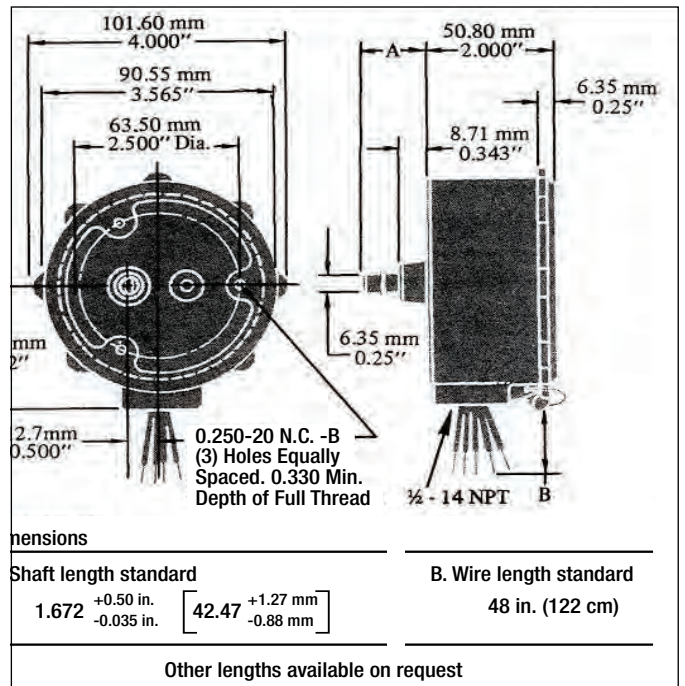

Figure 4. Mounting Dimensions

3. Shaft coupling method shall be determined by the user. Drive shaft diameter is 0.25 inch (6.35 mm).

Wiring

See Figure 5 for output and operating voltage connections for Dual Output Models. See Figure 6 for output and operating voltage connections for Single Output Models.

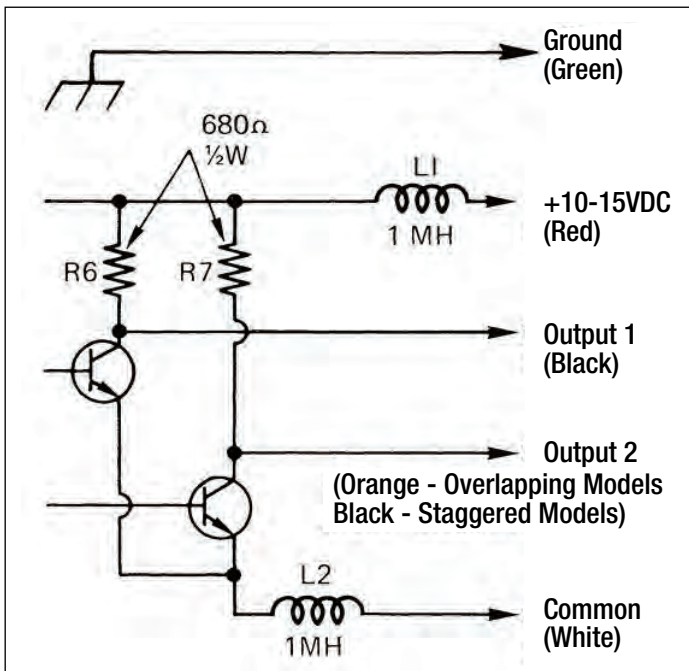

Figure 5. Wiring Connections for Dual Output Models

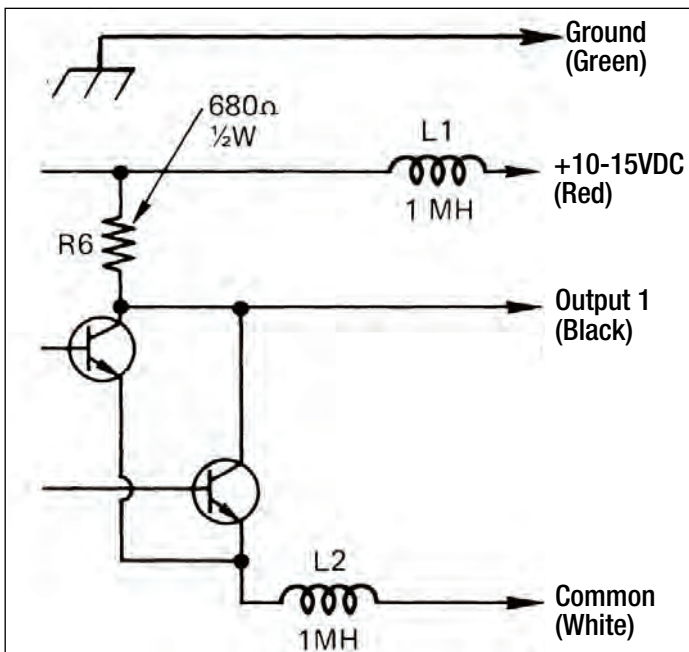

Figure 6. Wiring Connections for Single Output Models

NOTICE Green wire should be connected to ground where non-metallic conduit is used.

Operation Check

After installation and before normal use, check pulse transmitter and related circuitry for proper installation and operation.

NOTICE Be sure all wires are installed correctly before turning On the power since faulty installation can damage this unit.

1. Inspect all leads, connections, and ground. Be sure all external circuits are wired correctly.
2. Check for correct pulse transmission:
 - a. Turn on power.
 - b. Rotate shaft a specific number of turns.
 - c. Related equipment must confirm the number of pulses transmitted.
 - d. Turn off power.
3. Reexamine the installation to be certain all safety measures have been met and adequate protection is provided against possible damage. The system may be operated normally only after all the preceding checks have been performed and all corrections made.

SERVICE

Periodic Inspection

Establish regular intervals for inspection. Periods should be based on operating time and environmental conditions.

1. Inspect all leads and connections.
2. Check security of mounting and coupling condition.
3. Check condition of case and cover. Replace complete unit if either is cracked or severely damaged.
4. Be sure cover is tight.

NOTICE Transmitter is factory sealed. Do not remove cover.

5. Conduit must not be cracked or damaged. Replace as required.
6. Conduit seals must be in good condition. Replace as required to prevent seepage of fumes through cable.
7. Perform all post-installation steps as described in **Operation Check** section above.

Repair

It is NOT recommended that attempts to repair the pulse transmitter be made by users or their agents. The compact design of the pulse transmitter, made possible by the use of solid state devices, makes special knowledge and unique test equipment essential if serious damage to the electronic circuits is to be avoided. We therefore recommend that the pulse transmitter be returned to Veeder-Root for repair or adjustment.

Shipment

If the pulse transmitter must be returned to Veeder-Root for repair, perform the following steps:

1. Explain, in writing, the nature of the malfunction as accurately as possible. List the persons to be contacted in the event communication is required.
2. Place the letter along with the pulse transmitter and its packing material in its box.

3. Place in an overwrap box. Address to:
Veeder-Root Co.
2709 Route 764
Duncansville, PA 16635
4. All shipments must be prepaid.

CLAIMS AND WARRANTY

Damage Claims

1. Thoroughly examine all components and units as soon as received. If damaged, write on the face of the freight bill a complete and detailed description of the damage. Have the carrier's agent sign the description.

NOTICE **Insist that the carrier's agent verify the inspection and sign the description.**

2. Immediately notify the delivering carrier of damage or loss. This notification may be given in person or by telephone. Written confirmation must be mailed within 48 hours. Railroads and motor carriers are understandably reluctant to make adjustments for damaged merchandise unless inspected and reported promptly.
3. Risk of loss of, or damage to merchandise remains with the Buyer. It is the Buyer's responsibility to file a claim with the carrier involved.
4. Immediately advise your Veeder-Root representative, distributor, or the factory so that we may assist you.

Warranty And Conditions

1. **WARRANTY.** We warrant that our products shall be free from defects in material and workmanship for a period of one year from the date of shipment thereof or the product's total rated life, whichever first occurs. Within the warranty period we shall repair or replace such products which are returned to us with shipping charges prepaid and which are determined by us to be defective. This warranty will not apply to any product which has been subjected to misuse, negligence, or accident; or misapplied; or used in violation of product manuals, instructions, or warnings; or modified or repaired by unauthorized persons; or improperly installed.
2. **INSPECTION.** You shall inspect the product promptly after receipt and shall notify us at our Altoona office, in writing, of any claims, including claims of breach of warranty, within thirty days after you discover or should have discovered the facts upon which the claim is based. Your failure to give written notice of a claim within the time period shall be deemed to be a waiver of such claim.
3. **LIMITATION OF REMEDY AND WARRANTY.** The provisions of paragraph 1 are our sole obligation and exclude all other remedies or warranties, express or implied, including warranties of MERCHANTABILITY and FITNESS FOR A PARTICULAR PURPOSE, whether or not purposes or specifications are described herein. We further disclaim any responsibility whatsoever to you or to any other person for injury to person or damage to or loss of property or value caused by any product which has been subjected to misuse, negligence, or by accident; or misapplied; or used in violation of product

manuals, instructions, or warnings; or modified or repaired by unauthorized persons; or improperly installed.

4. **LIMITATIONS OF DAMAGES.** Under no circumstances shall we be liable for any incidental, consequential or special damages, losses or expenses arising from this contract or its performance or in connection with the use of, or inability to use, our product for any purpose whatsoever.
5. **LIMITATIONS OF ACTIONS.** No action regardless of form arising out of this contract may be commenced more than one year after the cause of action has accrued, except an action for nonpayment.
6. **COLLATERAL PROMISES.** There are no representations, warranties, or conditions express or implied, statutory or otherwise except those herein contained, and no agreements or waivers collateral hereto shall be binding on either party unless in writing and signed by you and accepted by us at our Altoona office.
7. **INTERPRETATION.** Rights and liabilities arising out of any contract with us shall be determined under the Uniform Commercial Code as enacted in Connecticut.