

IQ2 Control Box

Installation and Operation Manual

Notice

Veeder-Root makes no warranty of any kind with regard to this publication, including, but not limited to, the implied warranties of merchantability and fitness for a particular purpose.

Veeder-Root shall not be liable for errors contained herein or for incidental or consequential damages in connection with the furnishing, performance, or use of this publication.

Veeder-Root reserves the right to change system options or features, or the information contained in this publication.

This publication contains proprietary information which is protected by copyright. All rights reserved. No part of this publication may be photocopied, reproduced, or translated to another language without the prior written consent of Veeder-Root.

Contact Red Jacket Technical Support for additional troubleshooting information at 800-323-1799.

DAMAGE GOODS/LOST EQUIPMENT

Thoroughly examine all components and units as soon as they are received. If any cartons are damaged or missing, write a complete and detailed description of the damage or shortage on the face of the freight bill. The carrier's agent must verify the inspection and sign the description. Refuse only the damaged product, not the entire shipment.

VR must be notified of any damages and/or shortages within 30 days of receipt of the shipment, as stated in our Terms and Conditions.

VEEDER-ROOT'S PREFERRED CARRIER

1. Email V/R Customer Service at customerservice@veeder.com (or call 800-873-3313) listing the specific part numbers and quantities that were received damaged or lost.
2. VR will file the claim with the carrier and replace the damaged/missing product at no charge to the customer. Customer Service will work with production facility to have the replacement product shipped as soon as possible.

CUSTOMER'S PREFERRED CARRIER

1. Customer files claim with carrier.
2. Customer may submit a replacement purchase order. Customer Service will work with production facility to have the replacement product shipped as soon as possible.
3. If "lost" equipment is delivered at a later date and is not needed, VR will allow a Return to Stock without a restocking fee.
4. VR will NOT be responsible for any compensation when a customer chooses their own carrier.

RETURN SHIPPING

For the parts return procedure, please follow the instructions in the "General Returned Goods Policy" pages of the "Policies and Literature" section of the Veeder-Root North American Red Jacket Mechanical Products Price Book. Veeder-Root will not accept any return product without a Return Goods Authorization (RGA) number clearly printed on the outside of the package.

RESPONSIBILITIES OF THE INSTALLER AND STATION OWNER

This installation, operation and service instruction manual shall be left with the owner of the service station at which this equipment is installed. Retain these instructions for future use and provide them to persons servicing or removing this equipment.

FCC INFORMATION

Please see next page, iii.

Veeder-Root Company • 2709 Route 764 • Duncansville, PA 16635

©Veeder-Root 2026. All rights reserved.

FCC Information

This equipment complies with part 15 of the FCC Rules. Operation is subject to the following two conditions: (1) this device may not cause harmful interference, and (2) this device must accept any interference received, including interference that may cause undesired operation.

Note: This equipment has been tested and found to comply with the limits for a Class A digital device, pursuant to part 15 of the FCC Rules. These limits are designed to provide reasonable protection against harmful interference when the equipment is operated in a commercial environment. This equipment generates, uses, and can radiate radio frequency energy and, if not installed and used in accordance with the instruction manual, may cause harmful interference to radio communications. Operation of this equipment in a residential area is likely to cause harmful interference in which case the user will be required to correct the interference at his own expense.

Any changes or modifications to this equipment not expressly approved by Veeder-Root could void your authority to operate the equipment.

Responsible party (contact for FCC matters only):

Veeder-Root Company
2709 Route 764
Duncansville, PA 16635

Introduction

Notes To Contractor/Installer	1
IQ2 Network System Parts	1
Safety Precautions	2
Theory of Operation	2
IQ2 Front Panel Controls	3
LCD Display.....	3
LED Lights.....	3
Menu Navigation Buttons	4
General Specifications	4
Output Load Ratings.....	4
Hook Signal (Dispenser Interface) Ratings	4
Environmental Ratings	4
Approvals.....	4
IQ2 Compatible Pumps	4
TLS-450PLUS/TLS4 Console Compatibility	4

Installation

Mounting the IQ2 Enclosure	5
Applicable Electrical Codes	6
Wiring Connections	6
Incoming Power Connections.....	6
Dispenser Interface Connection	7
Outgoing Power Connections.....	8
System Wiring Connections	9
TLS-450PLUS/IQ2 Controller Communication	10
Requirements for TLS-450PLUS/IQ2 Controller Communication	10
Installing the RS-485 Comm Module.....	13
TLS-450PLUS/IQ2 Controller Comm Connections	14
IQ2 Controller-Only Comm Connections	14

IQ2 Configurations

Operating Mode	16
Standalone Operating Mode.....	16
Direct Operating Mode	16
Sequential Operating Mode.....	17
ATG Operating Mode	17
Pump Model	17
Address	17

IPC Setup

Intelligent Pump Control (IPC) Feature Installation Procedure	18
Serial Port Setup	20
Tanks And Pumps	21
Pump Controller Setup	24
Pump Setup.....	25
Configure a Line	26
IPC Diagnostics	30
Pump Controller Communications.....	30
Reset	31
Pump Overview	32
Statistical Reports.....	33

IQ2 Menu Descriptions

Home and Clear Alarms Screen	36
Parameters Menus	37
Voltage Screen	38
Current Screen	38
Active Power Screen	38
Reactive Power Screen (VAR)	39
Apparent Power Screen (VA)	39
Power Factor Screen	39
Diagnostics Menu	40
Alarms	41
Warnings	41
Thermal Capacity	41
Help Value	42
Enclosure Temperature	42
Hook Switch	42
Contactor	43
Firmware Version	43
Hardware Version	43
Settings Menu	44
Bypass Mode	46
Operating Mode	46
Address	47
Phases	47
Pump Model	47
Help Threshold	47
Extended Run Warning	48
Reboot	48
Download Firmware	48
Other Screens	49
Power Lost	49
Error	49

Alarms and Warnings

Alarms	50
High Current Alarm	50
Locked Rotor Alarm	51
High Voltage Alarm	51
Phase Loss Alarm	51
Self-Test Alarm	51
Network Alarm	51
Dry Run Alarm	51
Warnings	52
Bypass Mode Warning	52
Low Voltage Warning	52
Open Circuit Warning	52
Over Temperature Warning	52
Setup Data Warning	52
Extended Run Warning	52

Troubleshooting

Alarms and Warnings	53
---------------------------	----

Firmware Update	
Firmware Version	57
Firmware Update	58
Firmware Update Driver	60
Parts List	62
Appendix A: IQ2 Supported Pump Models	

Figures

Figure 1.	Time Overcurrent Relay	3
Figure 2.	IQ2 Control Panel	3
Figure 3.	IQ2 Dimensions	5
Figure 4.	Single-Phase Power Connections	6
Figure 5.	Three-Phase Power Connections	7
Figure 6.	Dispenser Hook switch Connections	7
Figure 7.	Single-Phase Load Connections	8
Figure 8.	Three-Phase Load Connections	8
Figure 9.	Single-Phase System Connections	9
Figure 10.	Three-Phase System Connections	9
Figure 11.	0330020-618 Communications Card Jumper Settings	10
Figure 12.	0330020-639 Communications Card Jumper Settings	11
Figure 13.	0330020-640 Communications Card Jumper Settings	12
Figure 14.	Approved TLS-450PLUS RS-485 Ports for IQ2 Communication	13
Figure 15.	ATG Network Example	14
Figure 16.	IQ2 Controller-Only Single and Network Examples	15
Figure 17.	Home Screen for Unconfigured IQ2	16
Figure 18.	Home Screen	18
Figure 19.	Inserting the USB Adapter Thumb Drive	18
Figure 20.	Upgrade Features Screen	19
Figure 21.	Confirm Feature Installation Pop Up Message	19
Figure 22.	Verify IPC Feature Installed in Overview/About Screen	20
Figure 23.	Serial Port Assignment	20
Figure 24.	Two Tanks Each With Two Pumps	21
Figure 25.	Selecting Pump Controller Screen	24
Figure 26.	Pumps Setup Screen	25
Figure 27.	Line Setup Screen - Page 1	26
Figure 28.	Line Setup Screen - Page 2	27
Figure 29.	Line Setup Screen - Page 3	29
Figure 30.	Example Pump Controller Communications Screen	30
Figure 31.	Displaying All Controller Addresses (Active and Configured)	30
Figure 32.	Resetting Controllers	31
Figure 33.	Example Pumps Overview Screen	32
Figure 34.	Example Pumps Overview Screen (Scrolled Down)	32
Figure 35.	Example Diagnostics Pump Controller Statistics Screen	33
Figure 36.	Example Diagnostics Pump Controller Statistics Screen (Scrolled to Right)	33
Figure 37.	Example Reports Pump Controller Statistics Screen	34
Figure 38.	Example Reports Pump Controller Statistics Screen (Scrolled to Right)	34
Figure 39.	IQ2 Root Menu Overview	35
Figure 40.	Alarms Menu	36
Figure 41.	Clear Alarms Screen with Fault	36
Figure 42.	Clear Alarms Screen without Fault	36

Figure 43.	Parameters Menu Entry and Exit	37
Figure 44.	Parameters Menu Screen Navigation	37
Figure 45.	Voltage Screen Single-Phase	38
Figure 46.	Voltage Screen Three-Phase	38
Figure 47.	Current Screen Single-Phase	38
Figure 48.	Current Screen Three-Phase	38
Figure 49.	Active Power Screen	38
Figure 50.	Reactive Power Screen	39
Figure 51.	Apparent Power Screen	39
Figure 52.	Power Factor Screen	39
Figure 53.	Diagnostics Menu Entry and Exit	40
Figure 54.	Diagnostics Menu Screen Navigation	40
Figure 55.	Alarms Screen without Alarms	41
Figure 56.	Warnings Screen without Alarms	41
Figure 57.	Thermal Capacity Screen	41
Figure 58.	Help Value Screen	42
Figure 59.	Enclosure Temperature Screen	42
Figure 60.	Hook Switch Screen Off-Hook or Energized	42
Figure 61.	Hook Switch Screen On-Hook or De-Energized	42
Figure 62.	Contactor Screen Open (Pump De-Energized)	43
Figure 63.	Contactor Screen Closed (Pump Energized)	43
Figure 64.	Firmware Version Screen	43
Figure 65.	Hardware Version Screen	43
Figure 66.	Settings Menu Entry and Exit	44
Figure 67.	Settings Menu Screen Navigation	44
Figure 68.	Operating Mode Screen Display State	45
Figure 69.	Operating Mode Screen Editing State	45
Figure 70.	Operating Mode Screen Altered State	45
Figure 71.	Extended Run Warning Screen Examples	48
Figure 72.	Reboot Screen	48
Figure 73.	Download Firmware Screen	48
Figure 74.	Power Lost Screen	49
Figure 75.	Error Screen	49
Figure 76.	IQ2 Class 10 Inverse Trip Curve	50
Figure 77.	Home Screen	57
Figure 78.	Diagnostics Menu Screen	57
Figure 79.	Alarms Screen	57
Figure 80.	Firmware Version Screen	57
Figure 81.	Connecting Laptop to IQ2 Comm Panel	58
Figure 82.	Windows Defender SmartScreen	58
Figure 83.	IQ2 Firmware Downloading Sequence Example	59
Figure 84.	IQ2 Firmware Download Error Example	59
Figure 85.	Accessing Device Manager	60
Figure 86.	USB Controller Window Example	60
Figure 87.	Confrim Device Uninstall Window	61
Figure 88.	IQ2 Driver Software Folder Example	61
Figure 89.	USB Controller Window Current Device Driver Example	61

Tables

Table 1.	IQ2 Network System Parts List	1
Table-2.	Operating Mode Address Ranges	17
Table 3.	Tank Staging Examples - Two Tanks W/Two Pumps Each	21
Table 4.	ATG System Alarm	53
Table 5.	ATG Line Setup Data Warnings	53
Table 6.	ATG Line Alarms	54
Table 7.	ATG Pump Alarm	54
Table 8.	ATG Pump Controller Setup Data Warning	54
Table 9.	ATG Pump Controller Alarms	54
Table 10.	IQ2 Pump Controller Alarms	55
Table 11.	IQ2 Pump Controller Warnings	56
Table-12.	Kit Parts	62
Table A-1.	IQ2 Supported Pump Models	A-1

Introduction

The IQ2 is a fixed speed motor controller for use with a Submersible Turbine Pump (STP) for fuel and associated transportation liquid delivery. The switching device is a three-phase contactor that is rated for up to 5 HP and up to 415 VAC operation in single or three-phase applications. The overload relay is designed for use with Red Jacket STPs and cannot be used with other motors without additional qualification by Veeder-Root.

The enclosure for the IQ2 is a powder-coated sheet metal box with a hinged door. Mounted on the door is an illuminated LCD display with two 16-character lines, 6 pushbuttons and 3 indicating lights.

There is a single digital input, rated for 110 – 250 VAC, to interface with dispenser hook-switch signals.

There are also two RJ-45 ports for supporting an incoming and outgoing connection to an RS-485 network that connects multiple IQ2's together with either an automated tank gauge (ATG) or a diagnostic interface.

There is one USB-C port for IQ2 software maintenance. This port does not support any other functionality nor does it provide power to charge or power external devices.



The USB-C port is for service personnel use only!

Internal to the IQ2 is a series of terminal blocks with screw terminals. One terminal block has 5 positions for incoming 3-phase power and the hook signal. A separate 3-position terminal block is for outgoing power to the STP. An external capacitor may be required for STPs that do not integrate a capacitor into the pump housing.



The IQ2 has not been evaluated to meet the UL/CSA/IEC 60947-4-1 standard.

Notes To Contractor/Installer

A Veeder-Root certified installer is required to install/work on the equipment discussed herein. Should the equipment be used in a manner not specified, the protection provided by the equipment may be compromised.





IQ2 Network System Parts



Table 1. IQ2 Network System Parts List

Part Number	Description	Qty. Req'd.
041 1066-001	This is a complete kit for creating a network containing a TLS-450 Plus and up to 31 IQ2's. The adapter is a short 24 cm (9.45") cable with an RJ-45 connector on one end for connecting to a TLS-450 Plus and an RJ-45 receptacle on the other end for using standard Ethernet cabling to connect to one or more IQ2's. The terminator is a small RJ-45 plug that is connected to the open RJ-45 receptacle on the IQ2 that is at the end of the network (see Figure 15).	1 per ATG serial port supporting an IQ2 network
041 1067-001	This kit contains two terminators, which are small RJ-45 plugs, for connection to the open RJ-45 receptacle on the IQ2 that is at the end of the network (see Figure 16). Only one terminator is required per network.	1 per IQ2 manifold network

Safety Precautions

The following safety symbols are used throughout this manual to alert you to important safety hazards and precautions.

 <p>ELECTRICITY High voltage exists in, and is supplied to, the device. A potential shock hazard exists. Turn Off power to the device and associated accessories when servicing the unit</p>	 <p>WARNING Pay close attention to the stated procedures and precautions to avoid the noted hazards.</p>
 <p>NOTICE Is used to address practices not related to physical injury.</p>	 <p>GROUND TERMINAL Protective Conductor Terminal IEC 60417-5019 (2006-08)</p>
 <p>READ ALL RELATED MANUALS Knowledge of all related procedures before you begin work is important. Read and understand all manuals thoroughly. If you do not understand a procedure, ask someone who does.</p>	

 WARNING	
 	<p>FAILURE TO COMPLY WITH THE FOLLOWING WARNINGS AND SAFETY PRECAUTIONS COULD CAUSE DAMAGE TO PROPERTY, ENVIRONMENT, RESULTING IN SERIOUS INJURY OR DEATH.</p> <ol style="list-style-type: none"> All installation work must comply with the latest issue of the National Electrical Code (NFPA 70), the Code for Motor Fuel Dispensing Facilities and Repair Garages (NFPA 30A), and any European, national, state, and local code requirements that apply. To protect yourself and others from serious injury, death, or substantial property damage, carefully read and follow all warnings and instructions in this manual. Only one level of protection is provided between the USB port and incoming power. Proper precautions, such as the use of a USB isolator, should be used by service personnel.

Theory of Operation

The IQ2 measures single and three phase voltage(s) and current(s) at up to 120 times a second to ensure that the attached pump motor is operating safely and effectively. These measurements are evaluated in real-time to produce the following information:

- Line-to-Line Voltage (Single or Three-Phase)
- Average Voltage
- Current (Single or Three-Phase)
- Average Current
- Active Power
- Reactive Power
- Apparent Power
- Power Factor
- Line Frequency

For every set of measurements, combined with a series of parameters specific to the installed pump, a series of electronic relays are updated. The electronic relays model physical time-delay relays, except these relays pickup or dropout based on the various conditions asserting or de-asserting. An example relay is shown in Figure 1

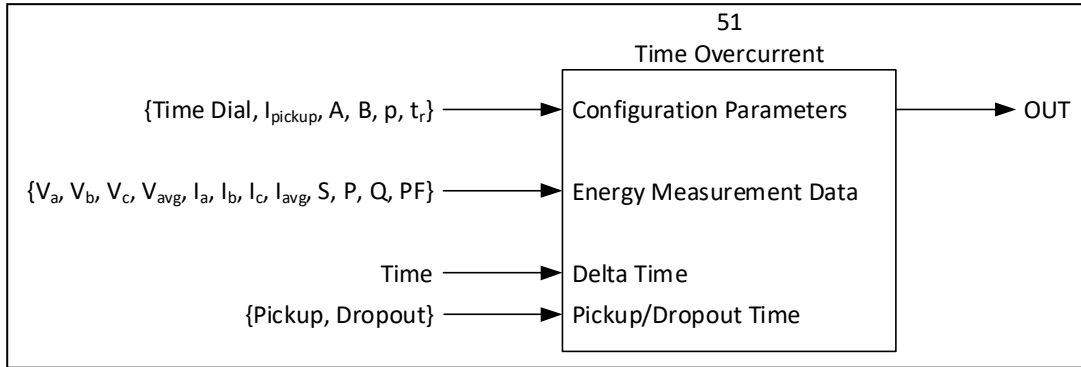

Figure 1. Time Overcurrent Relay

The time-overcurrent relay functions similar to a programmable circuit breaker and is a more consistent and controllable version of the bi-metallic strip found in a basic motor starter employing a thermal overload.

IQ2 Front Panel Controls

LCD Display

The 2-line, 16 character per line LCD display shows the current status of the IQ2 and is also used to set up and monitor the IQ2 (see Figure 2). The LCD has a white backlight that is always enabled.

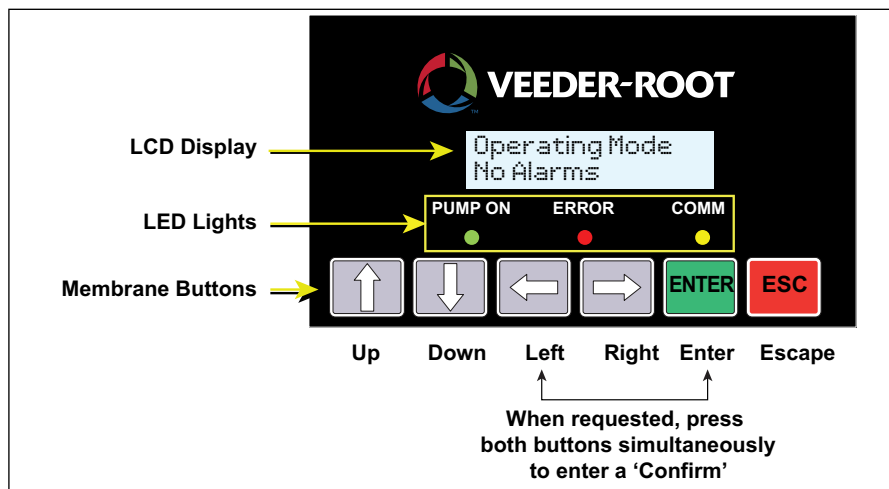

Figure 2. IQ2 Control Panel

LED Lights

PUMP ON - Illuminates green when the pump contactor should be closed. This status is derived from the intended state of the contactor and may not represent that actual contactor state if the contactor is malfunctioning.

ERROR - Illuminates when there is either an active warning or alarm. If this light is continuously lit, a warning is present without any alarms. If this light is blinking at a rate of 2 blinks/second, an alarm is present.



When the ERROR light is blinking, a warning may or may not also be present.

COMM - Illuminates when the IQ2 is actively transmitting on the RS-485 network connected to the IQ2.

Menu Navigation Buttons

There are six membrane switches (buttons) on the IQ2 front control panel. The four arrow buttons are used for menu navigation and configuration editing. The **ENTER** and **ESC** (Escape) buttons are used to alter and accept configuration menu entries. Menu entries that contain the **Confirm?** message will require you to press both the **Left Arrow** and **ENTER** buttons simultaneously to continue.

General Specifications

Output Load Ratings

- 200 - 250 VAC 1P, 2 HP / 1.5 kW AC-3, 50/60 Hz MAX
- 200 - 415 VAC 3P, 5 HP / 3.75 kW AC-3, 50/60 Hz MAX
- 20 A/phase MAX

Hook Signal (Dispenser Interface) Ratings

- 110 – 250 VAC, 1.25 W MAX
- 5 mA MAX

Environmental Ratings

- Indoor Use Only in Non-Hazardous Location
- Altitude: 3000m (9,842 ft)
- Ambient Temperature: -5 to 55°C (23 to 131°F)
- Relative Humidity: 0 – 95% (non-condensing)
- Mains Supply Voltage Fluctuations: $\pm 10\%$
- Over Voltage Category: 600V CATIII
- Pollution Degree 3

Approvals

- UL 1238
- IEC 61010-1

IQ2 Compatible Pumps

See Appendix A for a complete list of approved pumps by IQ2 firmware version.

TLS-450PLUS/TLS4 Console Compatibility

IQ2 firmware version 4.03 or greater requires TLS-4XX console software 11A 233.62 or greater.

Installation

Mounting the IQ2 Enclosure

Carefully unpack the IQ2 from its shipping packaging. Attach the IQ2 to 3/4" (19mm) plywood (or acceptable equivalent) mounted on an interior wall using the four mounting flange hole pattern 6.37" x 9.50" (162 x 241mm) as shown in Figure 3. The use of #10 x 5/8" plywood or Oriented Strand Board (OSB) screws is recommended. Up to 1/4" (6mm) diameter screws can be used and all 4 screws must be installed. Install metal conduit or equivalent per local electrical codes between the IQ2 and the power panel using any of the designated knockouts. The IQ2 must be installed in an upright orientation within $\pm 30^\circ$ of vertical.

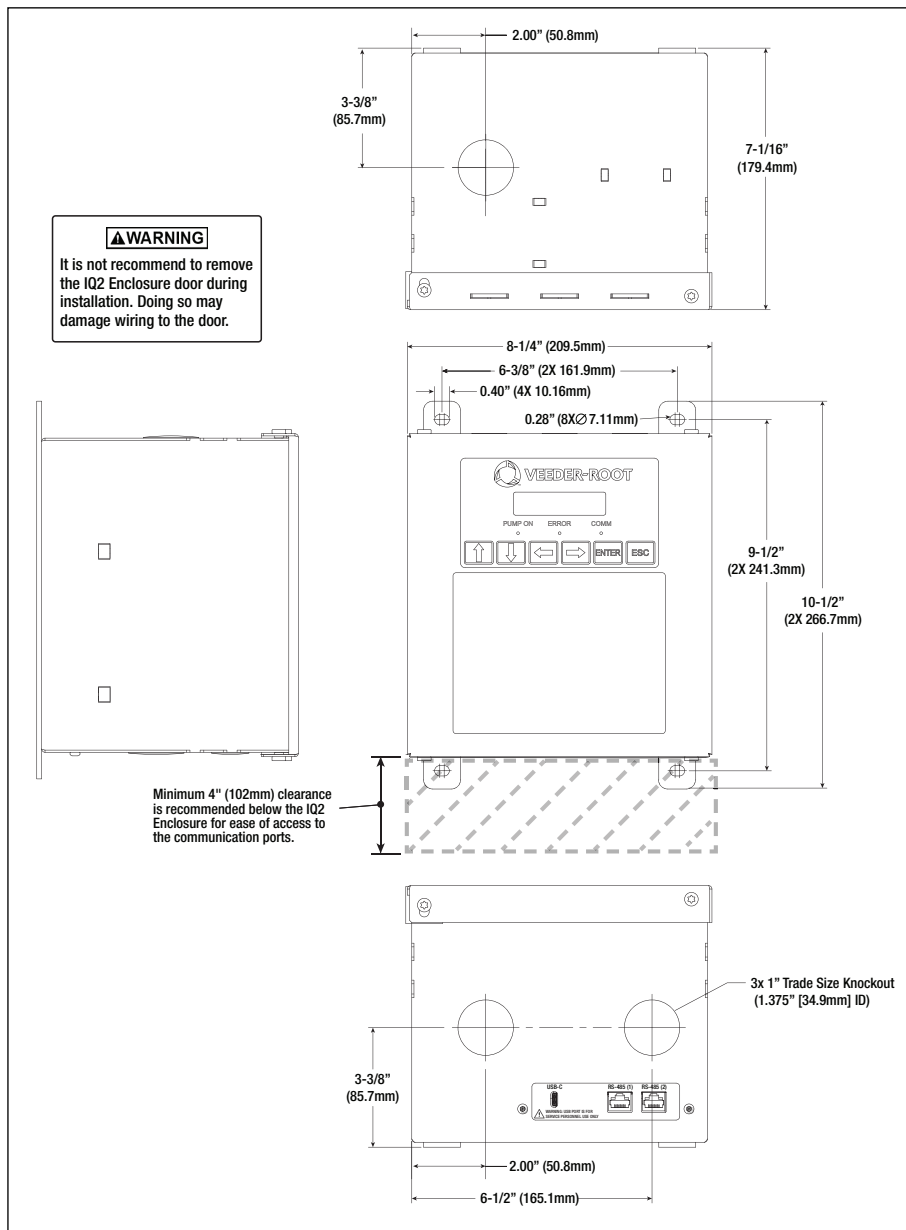

Figure 3. IQ2 Dimensions

Applicable Electrical Codes

The IQ2 must be installed in accordance with the following standards and requirements:

- National Electrical Code (NFPA 70)
- Flammable and Combustible Liquids Code (NFPA 30)
- Code for Motor Fuel Dispensing Facilities and Repair Garages (NFPA 30A)

Wiring Connections



WARNING: EQUIPMENT HAS MULTIPLE POWER SOURCES.

Locate and remove the enclosure knockouts where needed to terminate field wiring. The TB1 and TB2 terminal blocks are labeled for the following installation locations for field wiring.

- L1 – L3: Incoming power (phases A, B, C respectively) - TB1
- D1 – D2: Hook switch (ordering of wires is not important) - TB1
- T1 – T3: Outgoing power to the pump - TB2
- GND: Grounding wire terminations point on both incoming and outgoing power

Terminate all field wiring with #10 (4.8mm) lugs using the appropriate crimp tool appropriately sized for the conductor. The terminals can accommodate wiring between diameter #8 - #14 AWG (10-2.5mm²) and should be torqued to 20 lbf-in (2.3Nm) for connections to terminal blocks TB1 and TB2 and 27 lbf-in. (3Nm) for the ground connection. A #2 Phillips head and a slotted or 5/16" (8mm) socket are required for installing the terminated field wiring.

Incoming Power Connections

The IQ2 can be connected to single or three-phase incoming power (see Figure 4 and Figure 5). All incoming power connections must be made with at least 90°C (194°F) rated wiring and in accordance with all applicable electrical codes. The size of the incoming power conductors will vary with the load size and distance from the power panel. The conductor size should be rated for at least 125% FLA of an attached motor. The branch circuit breaker must be sized appropriately for the load.

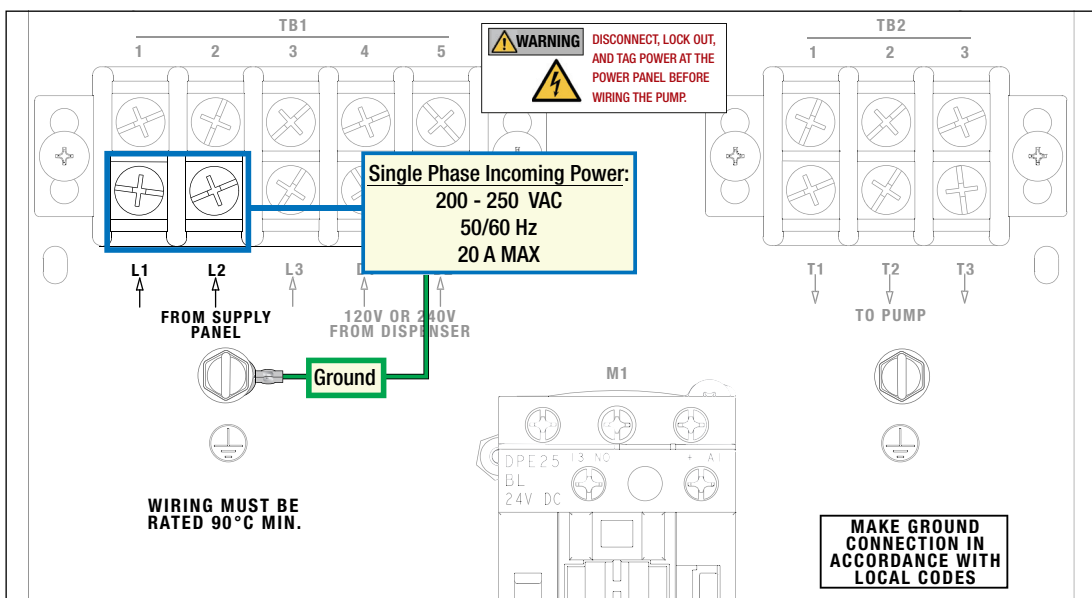

Figure 4. Single-Phase Power Connections

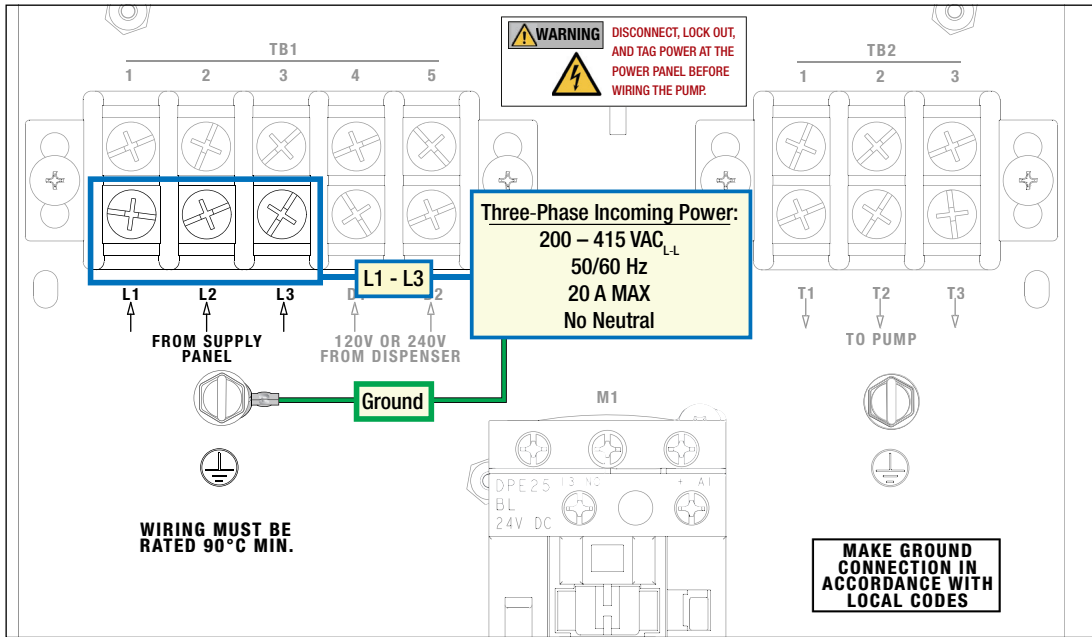

Figure 5. Three-Phase Power Connections

Dispenser Interface Connection

The dispenser interface or hook switch signal is used for all Operating Modes except for the ATG Operating Mode (see Figure 6). This interface may be directly connected to a single dispenser interface. If there are multiple dispensers, a dispenser isolation device, such as a Veeder-Root Isotrol, must be used. This connection may be made with #18 (1mm²) diameter or larger wiring rated at least 90°C (194°F) and in accordance with all applicable electrical codes.

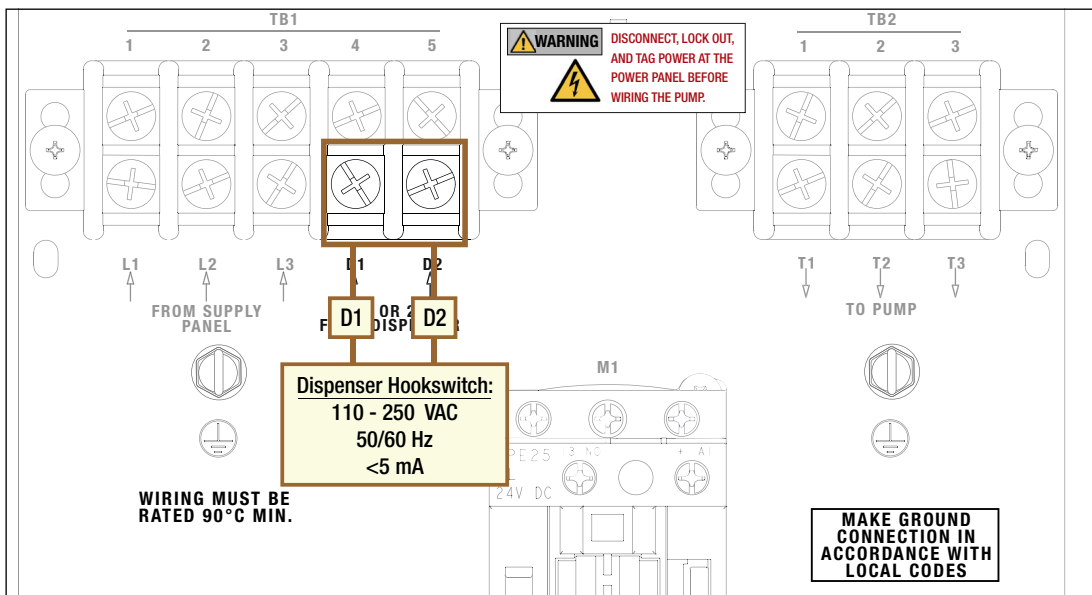

Figure 6. Dispenser Hook switch Connections

Outgoing Power Connections

The IQ2 can be connected to single or three-phase load (see Figure 7 and Figure 8). All outgoing power connections must be made with at least 90°C (194°F) rated wiring and in accordance with all applicable electrical codes. The size of the outgoing power conductors will vary with the load size and distance to the attached load. The conductor size should be rated for at least 125% FLA of an attached motor.

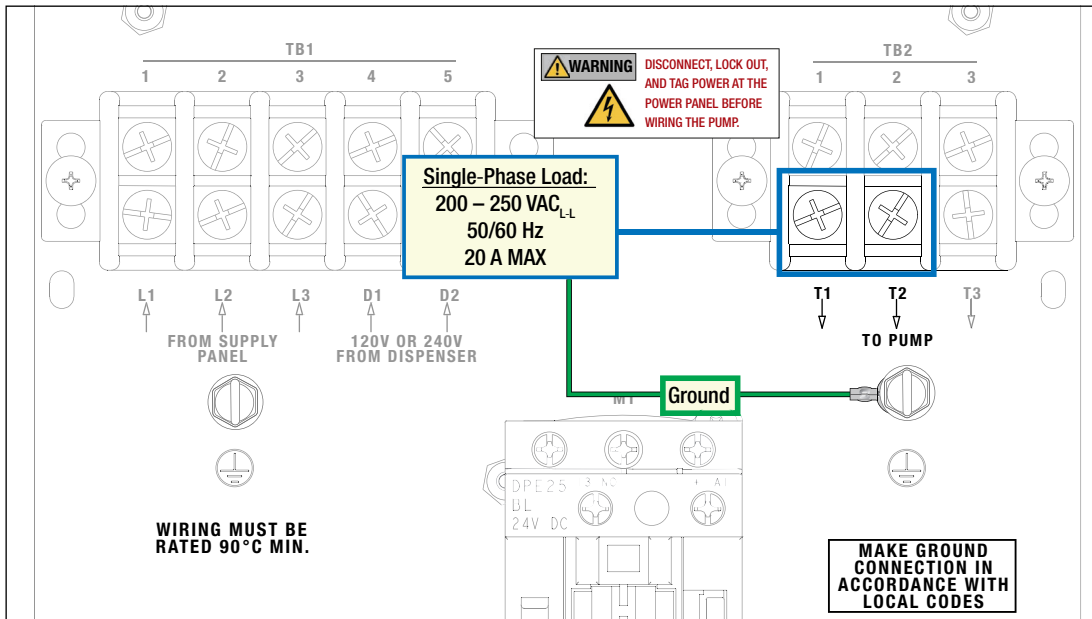

Figure 7. Single-Phase Load Connections

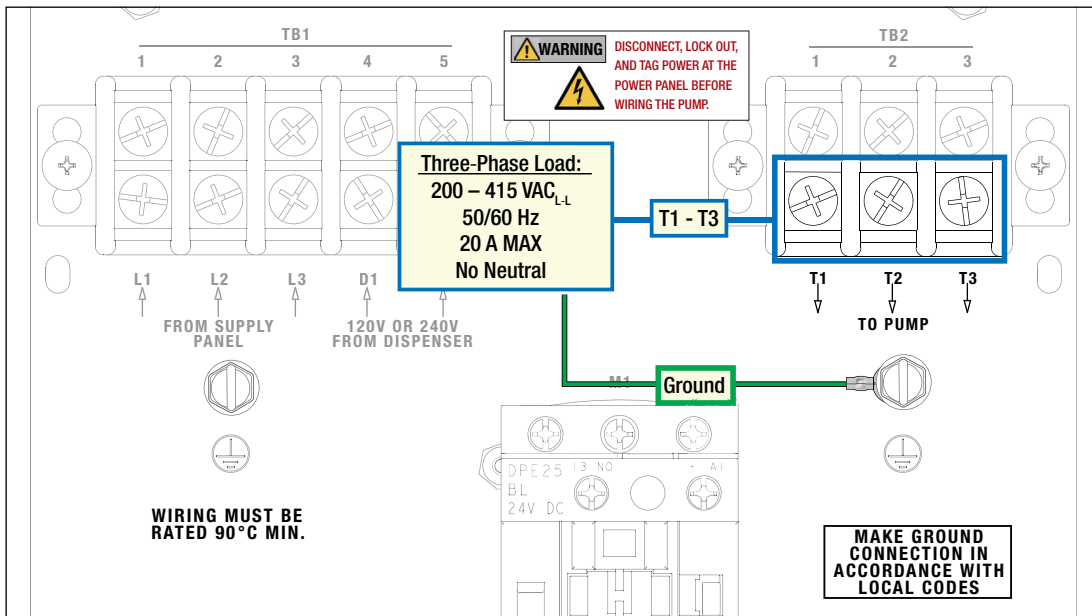

Figure 8. Three-Phase Load Connections

System Wiring Connections

The following figures show complete system level connections for both single and three-phase systems (see Figure 9 and Figure 10). The dispenser hook switch may or may not be connected, depending on the operating mode. If there are multiple dispensers, a dispenser isolation device, such as a Veeder-Root Isotrol, must be used.

For non-ATG operating modes, use the following single-phase and three-phase system connections.

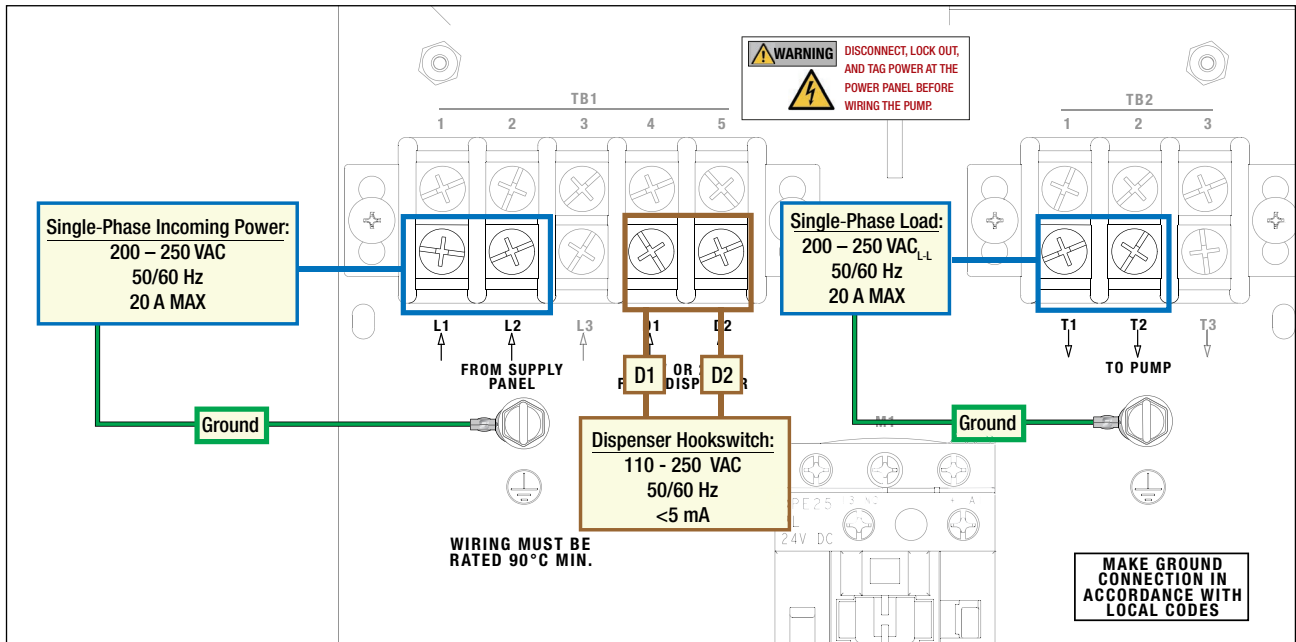

Figure 9. Single-Phase System Connections

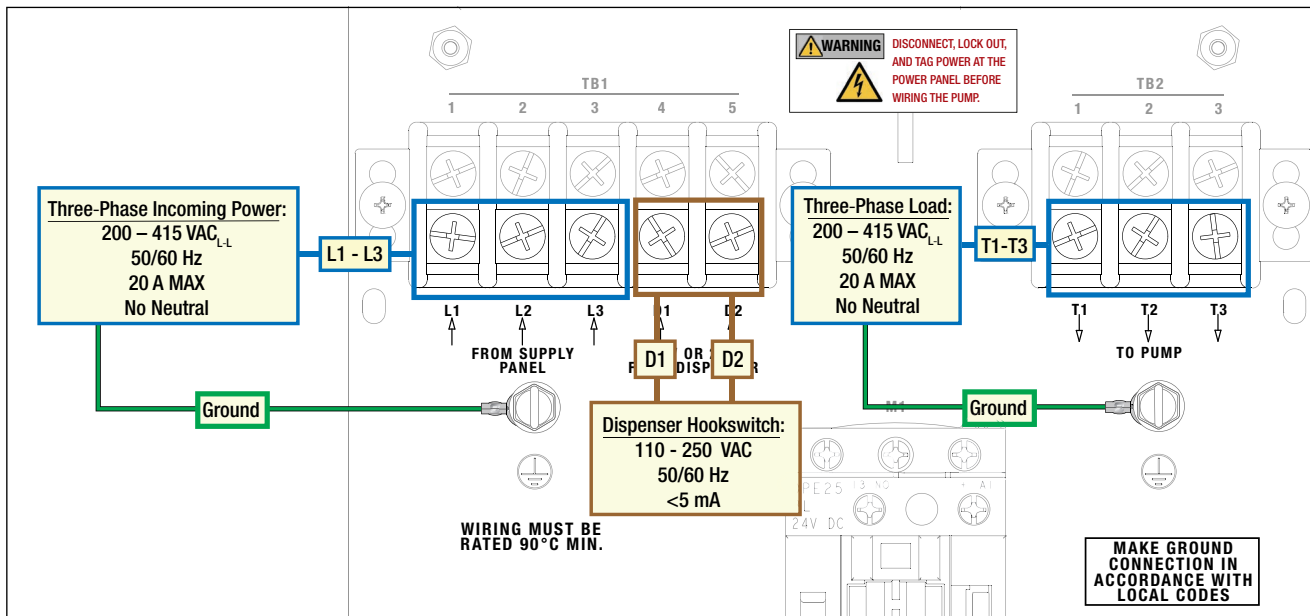

Figure 10. Three-Phase System Connections

For the ATG operating mode, follow the single-phase (see Figure 9) and three-phase system connections (see Figure 10) but omit the dispenser hook switch connection. The dispenser hook switch will instead be connected to the TLS-450Plus ATG.

TLS-450PLUS/IQ2 Controller Communication

Requirements for TLS-450PLUS/IQ2 Controller Communication

- An available RS-485 port in the TLS-450PLUS (Comm cards with part numbers 0330020-618, 0330020-639 and 0330020-640 are compatible). Depending which Comm card you use, you must configure Jumpers J7, 8 and 11 on that card for proper operation (see Figure 11- Figure 13 as required).

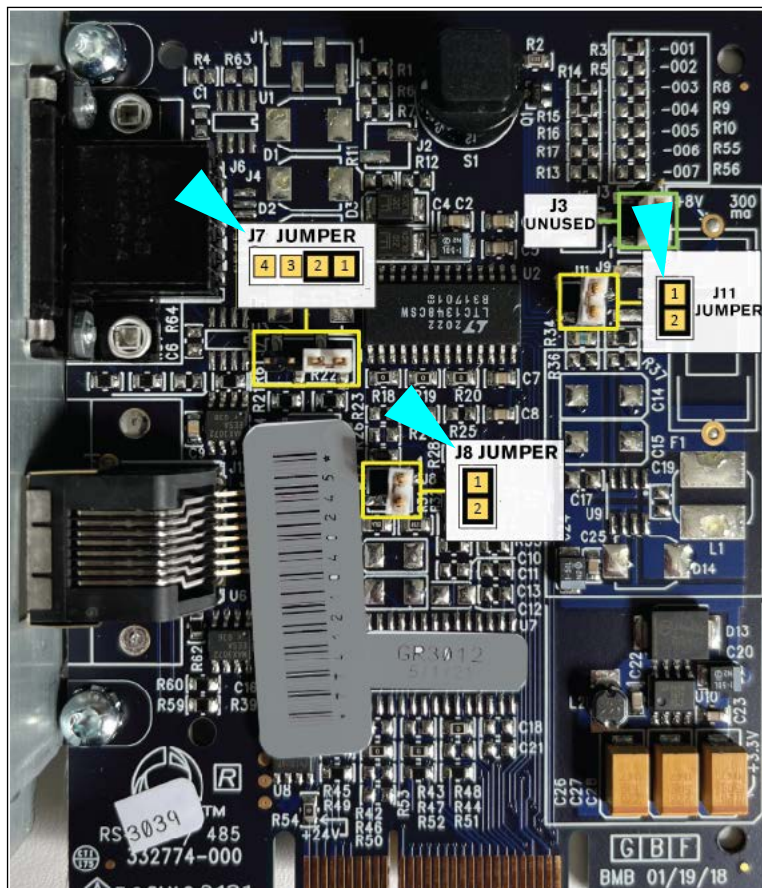

Figure 11. 0330020-618 Communications Card Jumper Settings

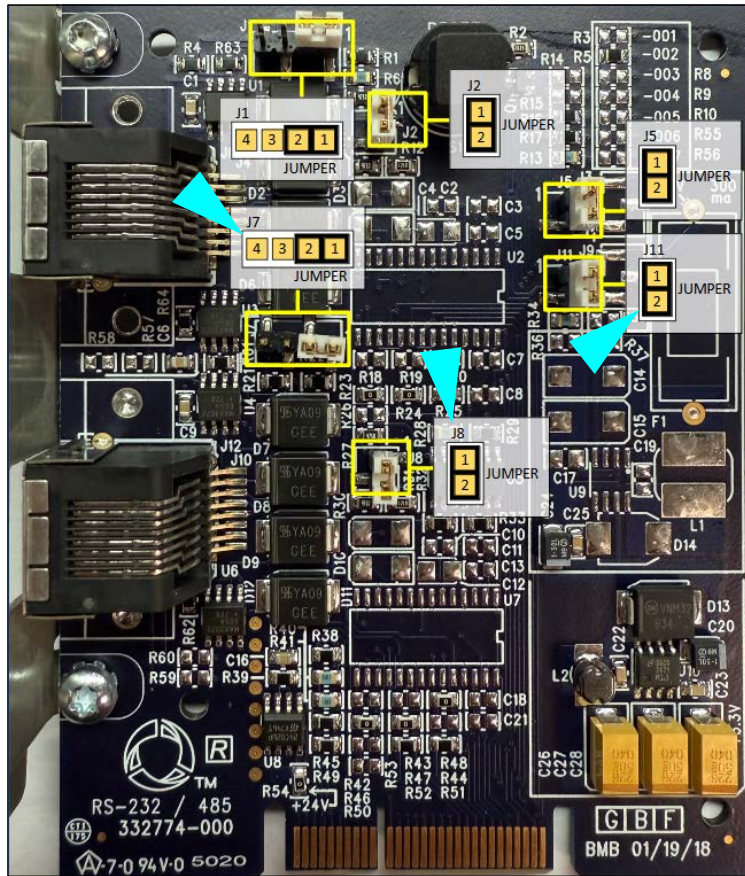

Figure 12. 0330020-639 Communications Card Jumper Settings

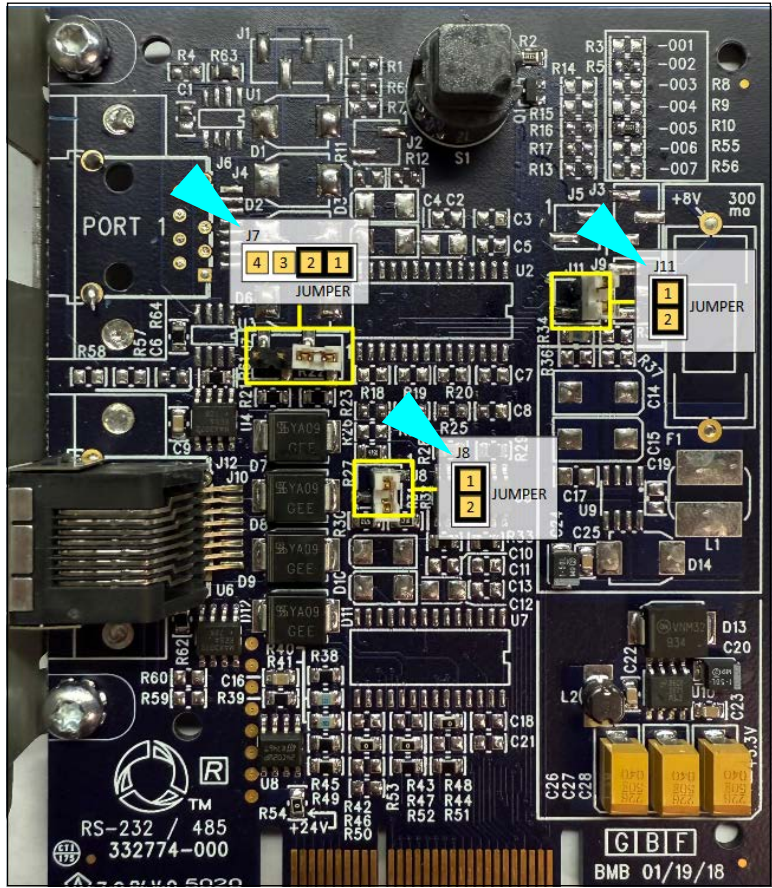

Figure 13. 0330020-640 Communications Card Jumper Settings

- An IQ2 Adapter Cable and IQ2 Network Terminator from kit No. 0411066-001
- Standard Ethernet cables for connecting IQ2 Controllers in the network and rated CAT 3 or better, including CAT 5, CAT 5e, CAT 6, or CAT 7.

Installing the RS-485 Comm Module

Figure 14 shows all possible RS-485 ports for IQ2 communication with the TLS-450PLUS.

! Use of RS-485 Ports 3 and 6 (Figure 14) must be approved by Veeder-Root Tech Support.

1. Install a properly configured RS-485 card into comm slot 1 or 2 (see installation example in Figure 14).

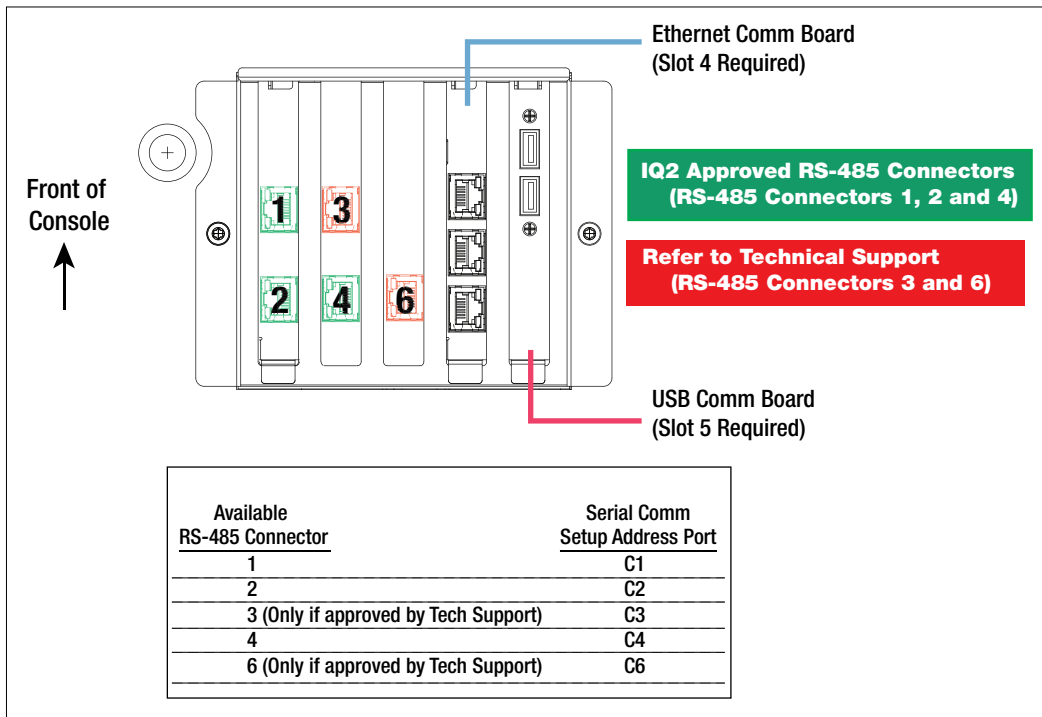

Figure 14. Approved TLS-450PLUS RS-485 Ports for IQ2 Communication

TLS-450PLUS/IQ2 Controller Comm Connections

1. Connect the IQ2 Adapter Cable to an approved RS-485 connector of the TLS-450PLUS.
2. Connect an Ethernet cable between the IQ2 Adapter Cable and a RS-485 comm port on the first IQ2 (see Figure 15).
3. If only one IQ2 is used, attach the IQ2 Network Terminator to the other IQ2 Controller RS-485 comm port.
4. If additional IQ2s are in the network, follow the connection example shown in Figure 15, making sure to insert the IQ2 Network Terminator in the unused RS-485 comm port of the last IQ2 Controller (Refer to Table 12 on page 62 for IQ2 Network kits).

A properly connected IQ2 network will always have every RS-485 comm port populated in every IQ2 that is part of the network.

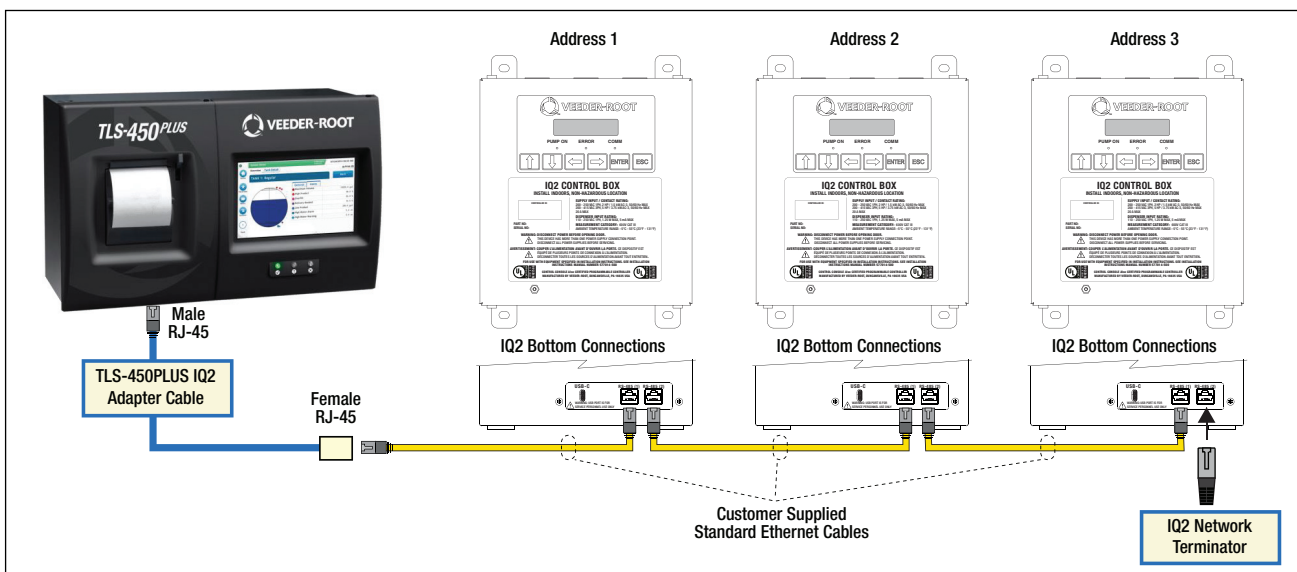

Figure 15. ATG Network Example

IQ2 Controller-Only Comm Connections

- ! **A unique IQ2 Controller network is required per line manifold. A line manifold supports a single product.**
- ! **The same hookswitch connection must be made between each IQ2 on the same network and the dispenser hookswitch provided by a dispenser isolation device. The connection may be daisy-chained between the IQ2's without any concerns about polarity.**

Follow the connection examples shown in Figure 16 for both single IQ2 Controller-Only and multiple IQ2 Controller-Only installations (refer to Table 12 on page 62 for IQ2 Network kits). Unique to installations that do not include a TLS-450Plus is the requirement that a common hookswitch for the manifold be connected to each IQ2 in the same network.

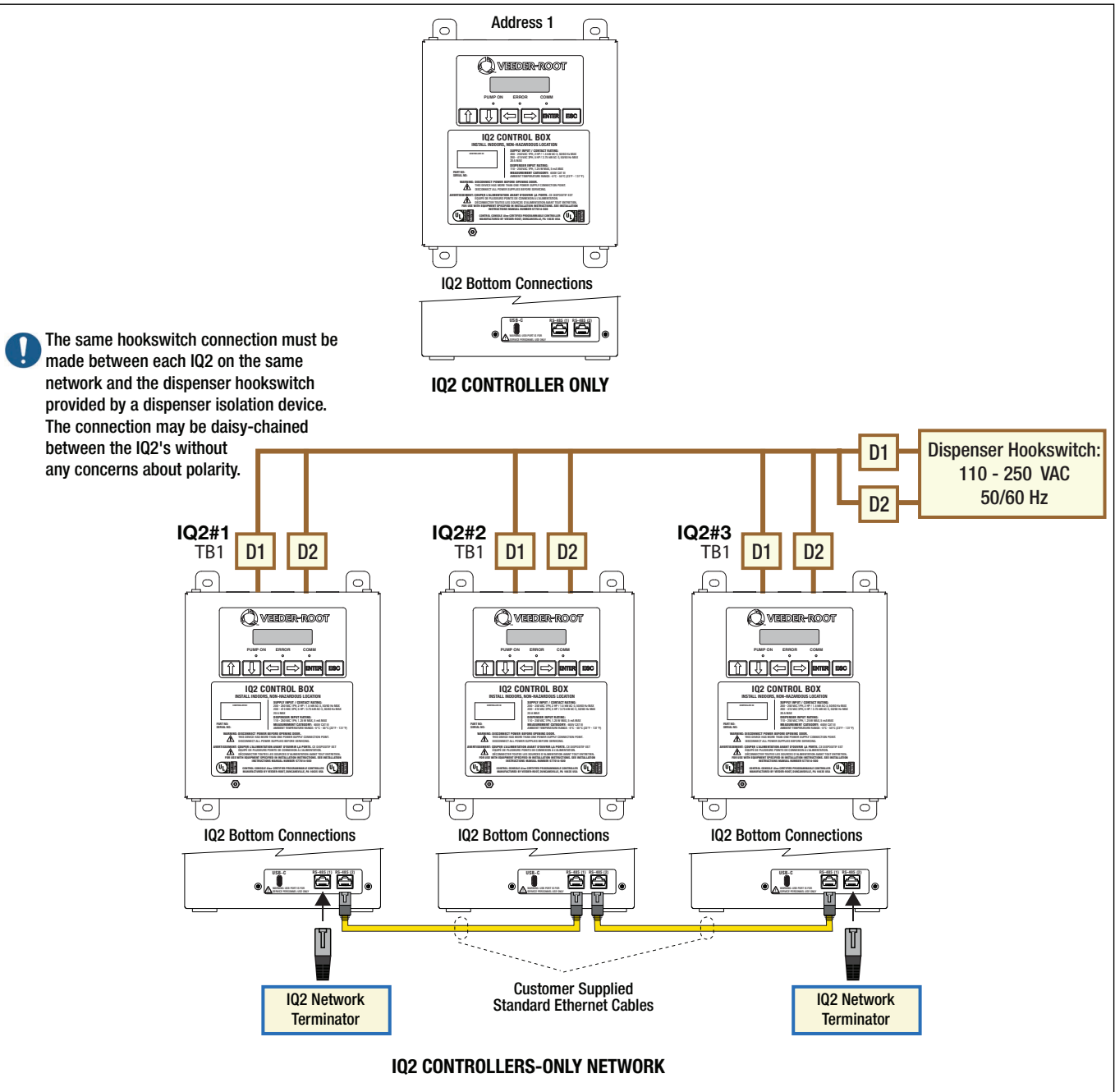

Figure 16. IQ2 Controller-Only Single and Network Examples

IQ2 Configurations

When an IQ2 is initially powered-on, it displays the Home screen. If the IQ2 is being powered on for the very first time, it is unconfigured. This is to prevent accidental energization of the attached pump until the IQ2 has been properly configured for the application. An unconfigured IQ2 Home screen will resemble Figure 17, with the red ERROR LED solid on.

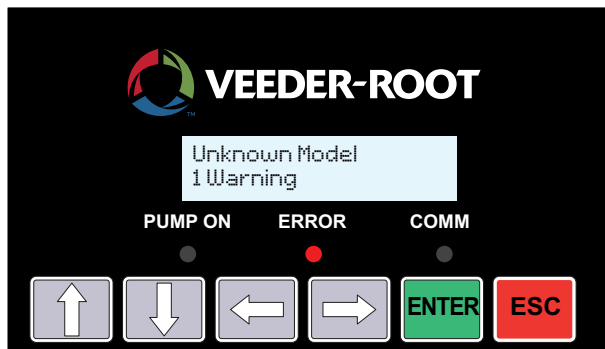

Figure 17. Home Screen for Unconfigured IQ2

The warning is displayed in Figure 17 is a Setup Error warning indicating that there is an issue with the IQ2 configuration. In this instance, there is no configuration.



When installing an IQ2, ensure that the latest firmware has been installed before configuring the IQ2.

There are several configuration items that must be edited to create a valid configuration. These include:

- Operating Mode
- Pump Model
- Address

Operating Mode

The Operating Mode must always be configured. The IQ2 supports 4 separate operating modes:

- Standalone
- Direct
- Sequential
- Automated Tank Gauge (ATG)

Standalone Operating Mode

The Standalone Operating Mode is intended for installations that use a single IQ2 that is operated by a hook-switch provided from a dispenser or multiple hook-switches provided from multiple dispensers using a dispenser isolation device, such as a Veeder-Root Isotrol. There is only a single pump and there are no additional pumps feeding a manifold. In Standalone Operating Mode, the RS-485 network supports MODBUS monitoring.

Direct Operating Mode

The Direct Operating Mode is intended for installations where up to 8 IQ2's are connected to pumps that feed a single manifold. Each IQ2 shares a hook-switch provided from multiple dispensers using an isolator. The RS-485 network supports P2P networking between each IQ2 on the same manifold. The RS-485 network shall not be

connected to an IQ2 on a separate manifold. Direct Operating Mode always starts the lowest addressed IQ2 first and starts additional IQ2's in ascending address order to maintain a high flow-rate in the manifold.

Sequential Operating Mode

The Sequential Operating Mode is intended for installations where up to 8 IQ2's are connected to pumps that feed a single manifold. Each IQ2 shares a hook-switch provided from multiple dispensers using an isolator. The RS-485 network supports P2P networking between each IQ2 on the same manifold. The RS-485 network shall not be connected to an IQ2 on a separate manifold. Sequential Operating Mode alternates/rotates through all of the IQ2s in an ascending address order to maintain a high flow-rate in the manifold. Sequential Operating Mode attempts to level the wear on all the pumps in the manifold.

ATG Operating Mode

The ATG Operating Mode is intended for installations that use a TLS-450Plus ATG to support up to 31 IQ2s on up to 31 manifolds using a single RS-485 network. The ATG is operated by a hook-switch provided from a dispenser or multiple hook-switches provided from multiple dispensers using an isolator. In ATG mode, the RS-485 network supports MODBUS control of the IQ2s from the ATG with no hook-switch connections to the IQ2s.

Pump Model

The Pump Model must always be configured. The IQ2 supports multiple Pump Models. Pump Models are filtered into two separate lists by the number of electrical supply phases of the pump, i.e., one-phase and three-phase pumps.

Address

The IQ2 address must always be configured. The default address of an IQ2 when first powered-on is zero (0). Every device on the same RS-485 network must have a unique address.

The address has different meanings, depending on the Operating Mode and the implied RS-485 network type with which it is associated. Table 2 lists the available Address Ranges by Operating Mode.

Table-2. Operating Mode Address Ranges

Operating Mode	Address Range	Network Type
Standalone	1-31	MODBUS Monitoring
Direct	1-8	P2P
Sequential	1-8	P2P
ATG	1-31	MODBUS Control

IPC Setup

After the controllers are connected to the TLS-450PLUS RS-485 serial port, apply power to the console and let it boot up and display the Home Screen (see Figure 18).

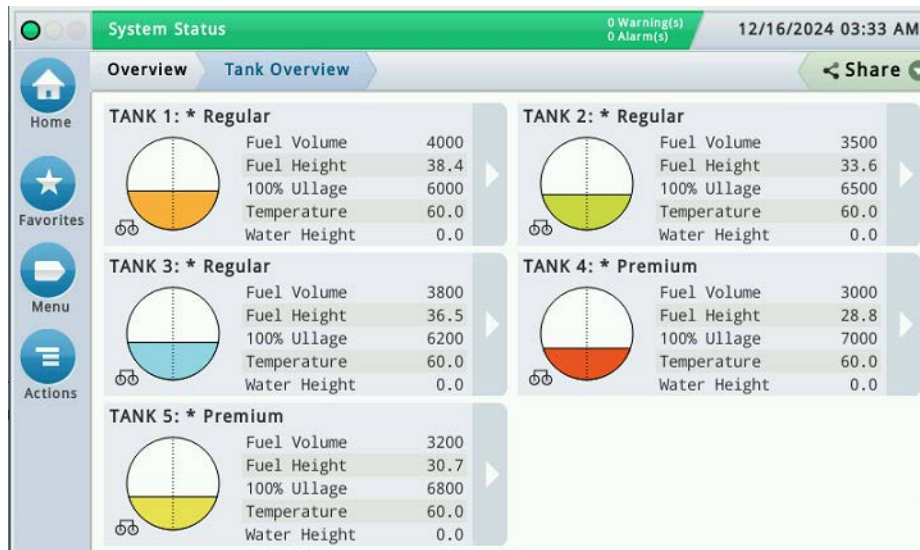

Figure 18. Home Screen

Intelligent Pump Control (IPC) Feature Installation Procedure

1. Get the USB adapter with the installed IPC feature upgrade iButton from the upgrade kit.
2. Insert the USB Adapter into one of the two USB ports in the bottom of the console as shown in Figure 19 below.

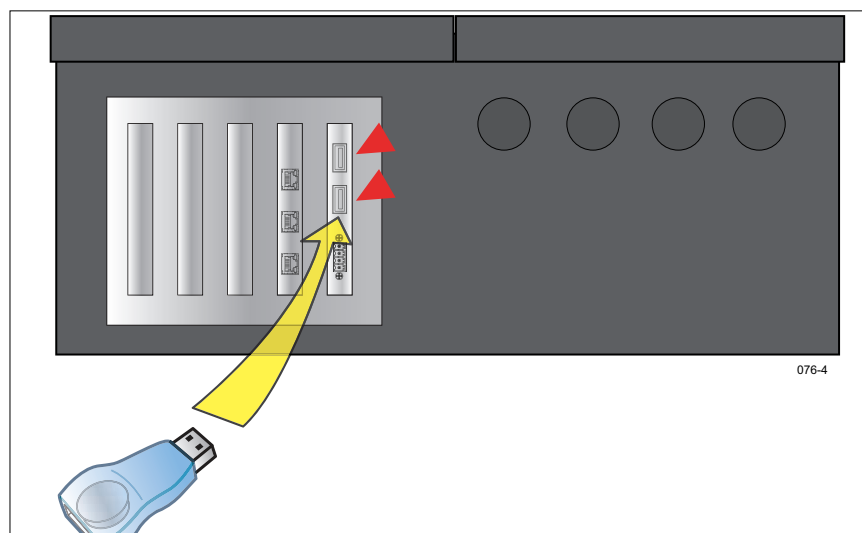

Figure 19. Inserting the USB Adapter Thumb Drive

3. From the Home Screen, navigate to **Menu>Software Maintenance>Upgrade Features** (see Figure 20.

! You will have to scroll to see the Upgrade Features option in Software Maintenance.

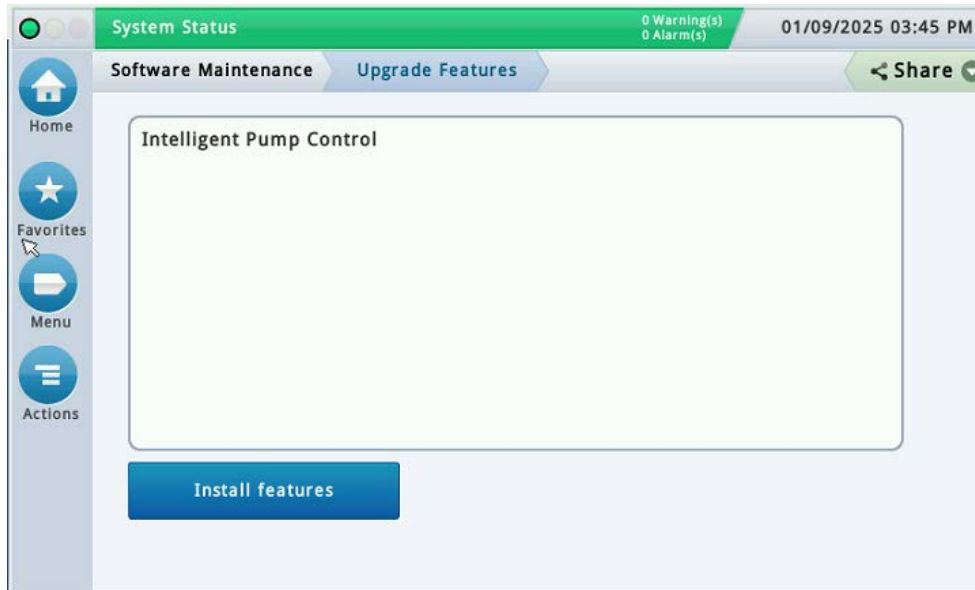

Figure 20. Upgrade Features Screen

4. Touch the **Install Features** button to start the installation process. A install confirmation pop up appears in the screen, touch the check (OK) button (see Figure 21). An installation complete message will appear at the bottom of the Install features screen when the software install has completed.

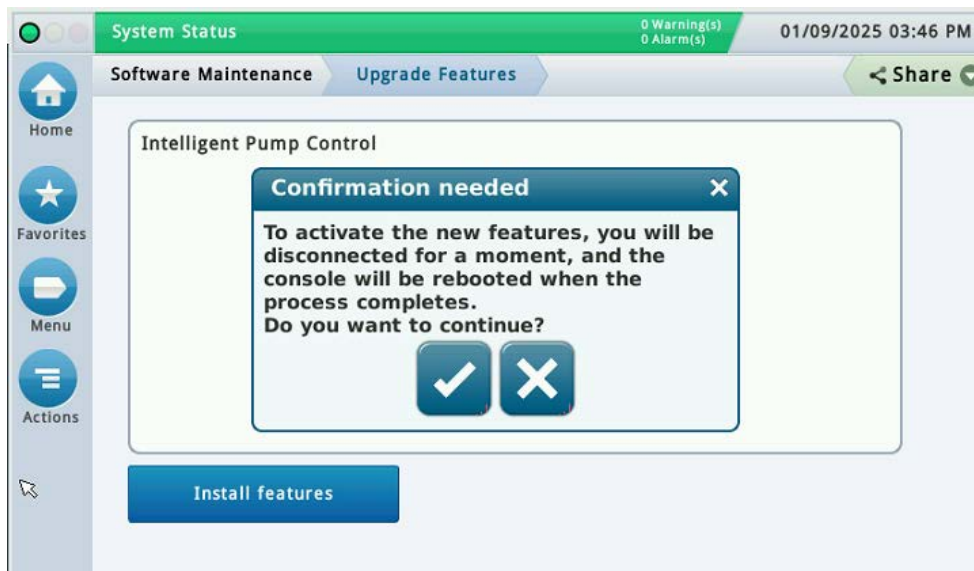

Figure 21. Confirm Feature Installation Pop Up Message

- When you have completed the Upgrade Features procedure, remove the upgrade thumb drive.
- From the Home Screen, navigate to **Menu > Overview > About** screen and verify the Intelligent Pump Control (IPC) feature was installed (see Figure 22).



Figure 22. Verify IPC Feature Installed in Overview/About Screen

SERIAL PORT SETUP

- From the Home screen, navigate to the **Setup > Communication > Serial Port** screen (see) Figure 23). In the **Usage** field, choose 'RJ IQ2 COMMS'

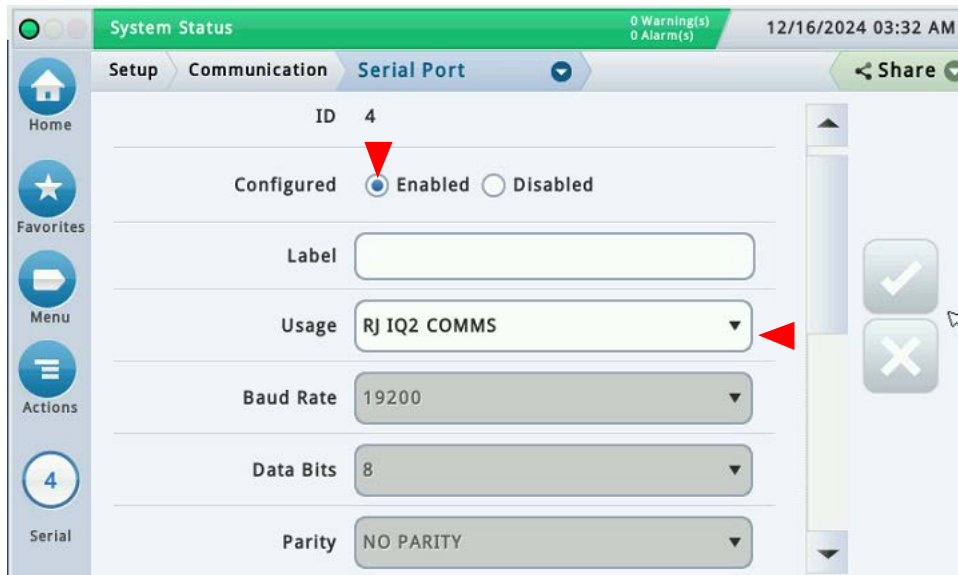



Figure 23. Serial Port Assignment

2. Select remaining serial port settings as per your site’s requirements. To view allowable selections for the remaining fields, for this and the following IPC setup screens, touch the Actions icon  then touch the Help icon .

Upon entering Help, the field information and allowable selections associated with the currently displayed screen will be visible. For multiple screen pages, touch the side scroll bar up/down arrows to scroll through all of the fields. Touch the ‘X’ in the right corner of the Help screen title bar to return to the TLS-450PLUS screen you were viewing.

3. Enable the Serial Port before saving.

Tanks And Pumps

Table 3 shows examples of which pump runs on a hook signal based on two tanks with two pumps in each tank (see Figure 24).

Two settings in **Setup > Pumps and Lines > Line** determine which pumps run on a hook signal with Intelligent Pump Control: The Dispense Mode and the pump controller mode (Stand-alone, Primary/Secondary, or Alternate). The Dispense Mode determines which tank is selected. (Siphon-manifolded tanks are considered one tank for this purpose.) The pump controller mode determines which of the pumps contained in the tank (also known as a pump set) pumps next.

When staging is included in the configuration, In Tank Staging enables help within a pump set. Across Tank Staging enables help across line-manifolded tanks.

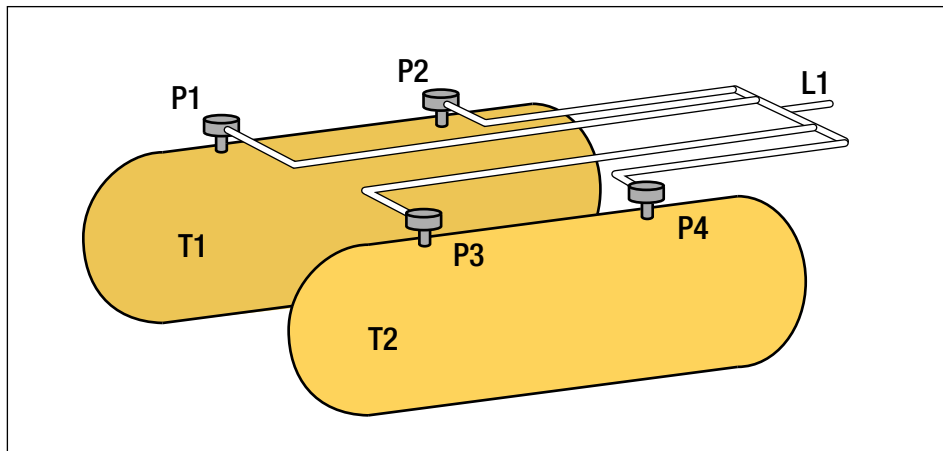

Figure 24. Two Tanks Each With Two Pumps

Table 3. Tank Staging Examples - Two Tanks W/Two Pumps Each

Dispense Mode	Pump Controller Mode (One Pump, Primary/Secondary, Or Alternate)	Pump That Runs At Hook Signal
Standard	The ATG does not do any tank-based pump control. It will turn on the pumps that inputs are connected to and will only inhibit dispensing due to alarms. This mode does not support staging, redundancy, or backfill protection.	

Table 3. Tank Staging Examples - Two Tanks W/Two Pumps Each





Dispense Mode	Pump Controller Mode (One Pump, Primary/Secondary, Or Alternate)	Pump That Runs At Hook Signal
All Pumps	This mode does not support Intelligent Pump Control staging, redundancy, or backfill protection.	All pumps are engaged when a hook signal is received.
Manifolded – Alternate Volume or Height (Tanks alternate based on volume or height.)	Stand-alone (one pump in a tank group – P1 and P3 in Figure 24 above)	The lone pump in the tank that meets the Alternate Volume or Height requirements at the time of hook signal.
	Pumps designated as: P1 Primary /P2 Secondary; P3 Primary /P4 Secondary	P1 (Primary only) or P3 (Primary only), depending on which tank meets requirements of alternate by volume or height. If staging is requested, the designated Secondary pumps assist in pump number order.  If a Primary pump is disabled, the lowest number Secondary becomes the temporary Primary.
	Pumps designated as: Alternate	P1 and P2 alternate (one at a time) or P3 and P4 (one at a time) alternate, depending on which tank meets requirements of alternate by volume or height. If staging is requested, the lowest numbered available pump run. With In Tank Staging, it will be a pump in the same tank. With Across Tank Staging, it will be a pump in any tank.
Sequential (Lowest number tank used first)	Stand-alone (one pump in a tank group– P1 and P3 in Figure 24 above)	The lowest number tank is selected, then the lone pump.
	Pumps designated as: P1 Primary /P2 Secondary; P3 Primary /P4 Secondary	P1 (Primary in lowest number tank) until tank reaches low product level, then P3 (Primary in next number tank) only. If staging is requested, P2 (the designated Secondary pump in pump order.) When the tank reaches the low product level, pumping will switch to the next tank with P3 (with P4 if staging is requested) until that tank reaches the low product level. In Tank Staging is used most often in this scenario.  If a Primary pump is disabled, the lowest number Secondary becomes the temporary Primary.
	Pumps designated as: Alternate	P1 and P2 (in lowest number tank) alternate until the tank reaches the low product level. When the tank reaches the low product level, pumping will switch to the next tank with P3 and P4 alternating until that tank reaches the low product level. If staging is requested: P1 and P2 (pumps in the lowest number tank) alternate. If both pumps are on and staging is requested, the remaining pumps are used in pump number order – this may be in a different tank if Across Tank Staging is enabled).

Table 3. Tank Staging Examples - Two Tanks W/Two Pumps Each

Dispense Mode	Pump Controller Mode (One Pump, Primary/Secondary, Or Alternate)	Pump That Runs At Hook Signal
Alternate by Pump (Pump selection by pump number; tank selection is ignored)  Although pumps may be out of order in tanks, they are in order in this example.	Stand-alone (one pump in a tank group– P1 and P3 in Figure 24 above)	The lone pump is selected.
	Pumps designated as: P1 Primary /P2 Secondary; P3 Primary /P4 Secondary	P1 then P3 (only Primary pumps run in pump number order, regardless of tank.) If staging is requested, P2 helps P1 and P4 helps P3.  If a Primary pump is disabled, the lowest number Secondary becomes the temporary Primary.
	Pumps designated as: Alternate	P1, then P2, then P3, then P4 (pumps alternate in pump number order) If staging is requested: the next pump helps in pump number order – this may be in a different tank if Across Tank Staging is enabled).

PUMP CONTROLLER SETUP

! The Serial Port must be configured before pump controllers are configured.

1. Navigate to the **Setup > Pumps and Lines > Pump Controller** screen (see Figure 25).

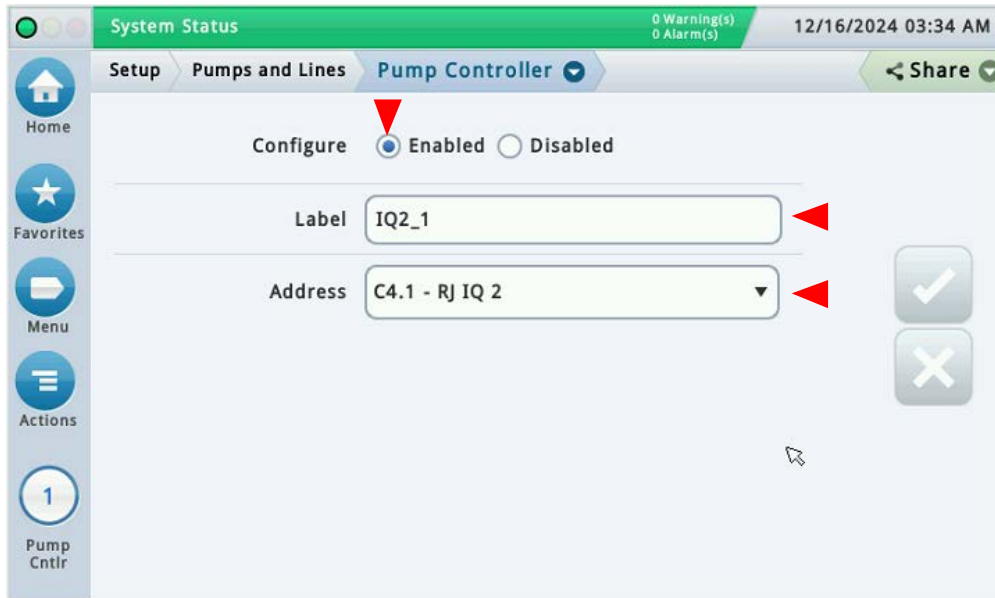

Figure 25. Selecting Pump Controller Screen

2. In the Label field enter a name for this Pump Controller (see Figure 25).
3. The Address field will contain all of the available pump controller types connected to IPC Comms serial port (e.g., IQ2). Reference your record of each controller's assigned Secondary address (1 to 31), to select the desired controller from the drop-down list. For example, the Address field in Figure 25, C4.1 RJ IQ 2, C4 = the IPC Comms serial port; 1 = Secondary address; and RJIQ2 Controller type assigned to that address.
4. Enable the Pump Controller before saving.

PUMP SETUP



The pump controllers must be configured before pumps are configured.

1. Navigate to the **Setup > Pumps and Lines > Pumps** screen. This screen includes both pump controllers and relays in the pump control field (see Figure 26).
 - a. In the Label field, enter a label for the pump.
 - b. In the Mode field, select TLS Pump Control. This indicates the pump is controlled or actuated by the console.
 - c. In the Tank field select the Tank in which the pump is installed.
 - d. In the Pump Control field select the pump's Controller.
 - e. In the Pump Sense field select the input to the pump.
 - f. Enable Pumps before saving.

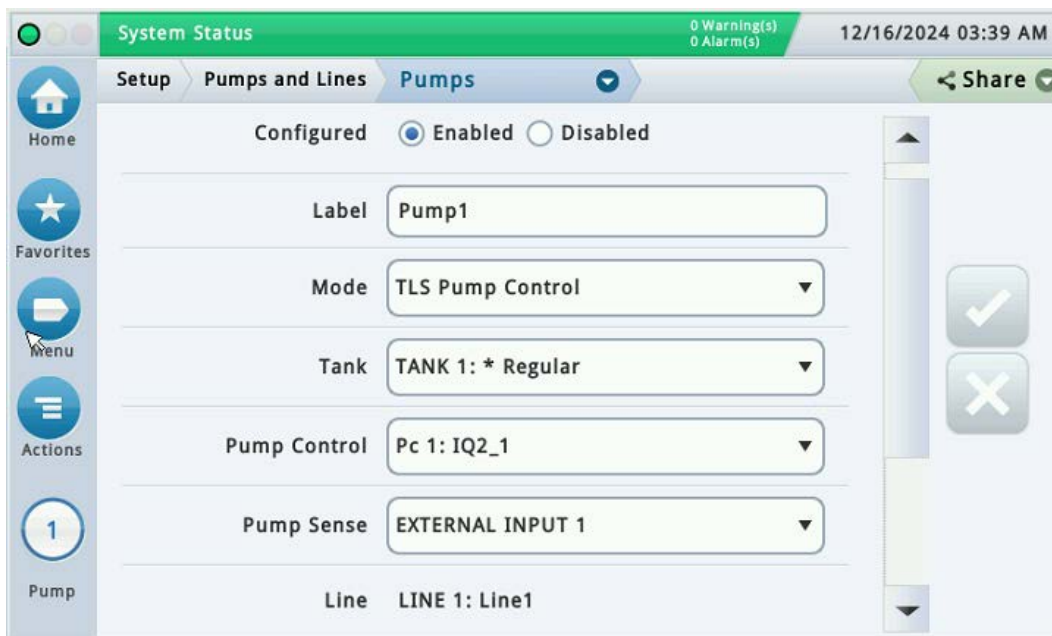

Figure 26. Pumps Setup Screen

CONFIGURE A LINE

! The pumps must be configured before lines are configured.

1. Navigate to the **Setup > Pumps and Lines > Line** screen. This screen lets you configure individual lines monitored by the console. This includes leak monitoring, Recirculation, IPC and line manifold settings.
2. Make the selections to page 1 of the Line screen based on the site's requirements (see Figure 27).



Figure 27. Line Setup Screen - Page 1

3. Select a Dispense Mode [Only enabled if Manifolded field is set to "Yes"]. For IPC requirements, page 2 of the Line screen lets you select the Dispense Mode and Staging Methods for multiple pumps on the line (see Figure 28). The Dispense Mode determines the order in which pumps are activated on a line. The staging method determines which pumps will provide additional pump capacity for a line when requested. Pumps can be designated to be in a Primary/Secondary configuration or can be selected to alternate.

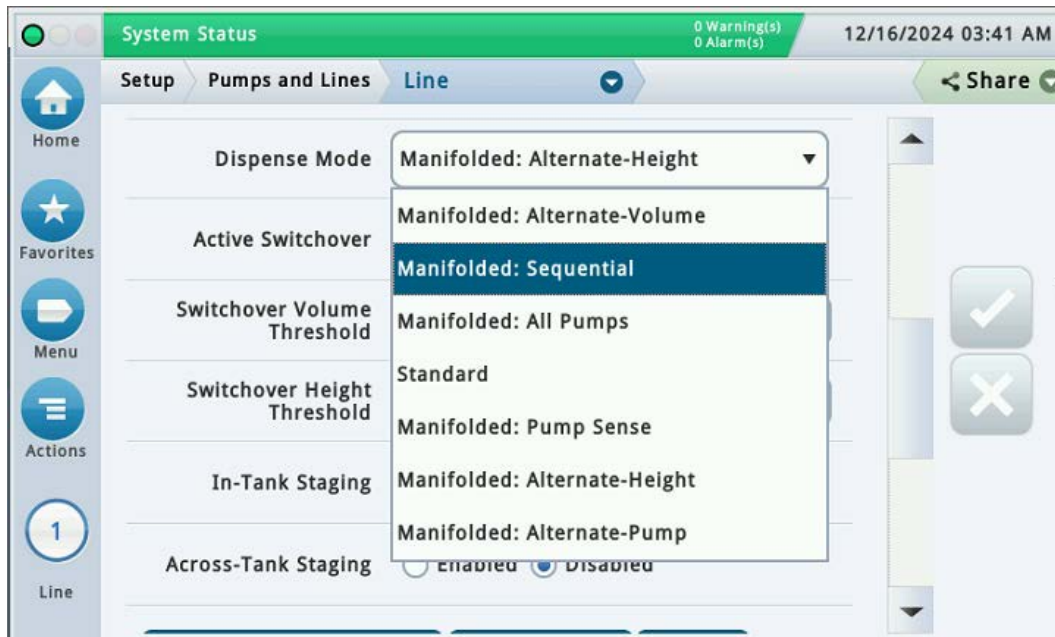

Figure 28. Line Setup Screen - Page 2

- a. Standard
Typically this means that only one pump feeds the line.
- b. Manifolded: Alternate - Volume
For line manifolded tanks, the console chooses the tank with the greatest inventory volume and switches to an alternate tank based on the Active Switchover and Threshold settings below.
- c. Manifolded: Sequential
If there is more than one tank with a pump on the line, tanks are pumped one at a time until the volume drops below the Pump Threshold (%) value set in the **Setup > Tank > General** screen. At that point, pumping will commence on the next available tank in the line set in sequential order by tank number.
- d. Manifolded: All Pumps
All pumps on the line are run
- e. Manifolded: Pump Sense
This is used for manifolded lines with pump sets that are controlled externally to the TLS (e.g., direct Primary/Secondary through pump controllers). Pump Sense input helps to evaluate busy periods for CSLD/SLD/Timed Sudden Loss.
- f. Manifolded: Alternate-Height
For line manifolded tanks, the console chooses the tank with the greatest height and switches to an alternate tank based on the Active Switchover and Threshold settings below.
- g. Manifolded: Alternate-Pump
Pump selection is based on pump number order. For each new hook signal, the next pump in the sequence (by pump number) is selected. If a tank has a Primary/Secondary pump configuration, only the Primary pumps are selected. There is no tank selection in this mode. This mode is intended for multiple pumps in the same tank or siphon-manifolded tanks. Use In-Tank Staging (see below) if you want to configure help for a pump.

4. Active Switchover

This field is active if either Alternate-Volume or Alternate-Height is selected in the Dispense Mode field above. Choices are:

- Yes - Enables the switchover to an alternate tank when dispensing, based on which tank has the greatest volume/height, taking into account the threshold value below
- No - Disables the switchover to an alternate tank when dispensing (default).

5. Switchover Volume Threshold

The volume used to determine when to switch over to an alternate tank in Manifolder: Alternate-Volume mode. When dispensing, the console switches to an alternate tank (without losing line pressure) when the difference is greater than this threshold. Set to a value between 10 and 999 gallons (37.85 and 3782 liters). The default value is 200 gallons (757.1 liters).

6. Switchover Height Threshold

The height used to determine when to switch over to an alternate tank in Manifolder: Alternate-Height mode. When dispensing, the console switches to an alternate tank (without losing line pressure) when the difference is greater than this threshold. Set to a value between 1 and 99 inches (25.4 and 2515mm). The default value is 2 inches (50.8mm).

7. In Tank Staging (IPC)

Enables/disables additional pump capacity (staging) provided by pumps within the same tank on the line when feedback from active pump controllers indicate help is necessary. The additional pumps stop when the hook signal is dropped. If pumps have a Primary/Secondary configuration (see below), the Secondary pumps must be in the same tank to be used for In Tank Staging.



If all devices are relays, staging is not available.

8. Across-Tank Staging (IPC)

Enables/disables additional pump capacity (staging) provided by pumps on the line, associated with other tanks. The additional pumps stop when the hook signal is dropped.

9. For the Line selected, page 3 of the Line screen lets you assign the appropriate pumps to the line (see Figure 29). Select a pump to assign to the line. If the Line Manifolder field above is set to Yes, you can select multiple pumps for this line. With Intelligent Pump Control, the pump name (P1 / T5 - Primary) may also include the pump (P1), the tank (T5) if assigned, and how this pump is used (Primary):

- In applicable Dispense Modes, when there is one pump in a tank (or siphon-manifolder tank group), it is marked 'Stand-Alone'. It is the only pump available to run.
- In applicable Dispense Modes, when there are two or more pumps in a tank (or siphon-manifolder tank group) and none are marked as a Primary pump, they are marked 'Alternate'. They alternate with each switch hook as determined by the Dispense Mode.
- If there are two or more pumps in a tank (or siphon-manifolder tank group) and one is checked as a Primary pump, all other pumps are marked 'Secondary'.

Primary (checkbox) - This checkbox indicates that this is a Primary pump in a Primary/Secondary multiple pump configuration for staging purposes. Only one pump per tank can be selected as a Primary. The Primary pump is always employed before the Secondary pump. If the Primary pump is unusable, the lowest numbered Secondary pump in the configuration becomes a temporary Primary.

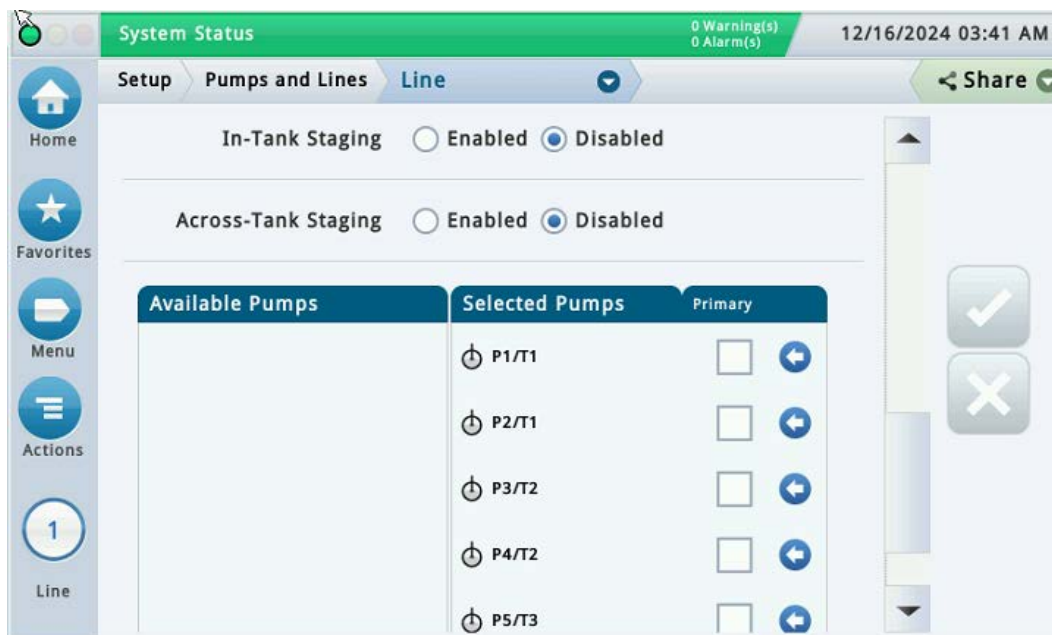

Figure 29. Line Setup Screen - Page 3

IPC Diagnostics

Pump Controller Communications

You can view pump controller information such as fault codes, pumps and lines associated with a pump controller and pump controller status by navigating to **Diagnostics > Pump Controller > Communications** (see Figure 30).

Address	Type	Gauge Mapping	ATG Status	PC Status	Line	Pump
<input checked="" type="checkbox"/> C4.1	RJ IQ 2	Pc 1: IQ2_1	Idle	OK	Ln 1	Pm 1
<input type="checkbox"/> C4.2	RJ IQ 2	Pc 2: IQ2_2	Idle	OK	Ln 1	Pm 2
<input type="checkbox"/> C4.3	RJ IQ 2	Pc 3: IQ2_3	Idle	OK	Ln 1	Pm 3
<input type="checkbox"/> C4.4	RJ IQ 2	Pc 4: IQ2_4	Idle	OK	Ln 1	Pm 4
<input type="checkbox"/> C4.5	RJ IQ 2	Pc 5: IQ2_5	Idle	OK	Ln 1	Pm 5
<input type="checkbox"/> C4.6	RJ IQ 2	Pc 6: IQ2_6	Idle	OK	Ln 1	Pm 6
<input type="checkbox"/> C4.7	RJ IQ 2	Pc 7: IQ2_7	Idle	OK	Ln 2	Pm 7
<input type="checkbox"/> C4.8	RJ IQ 2	Pc 8: IQ2_8	Idle	OK	Ln 2	Pm 8
<input type="checkbox"/> C4.9	RJ IQ 2	Pc 9: IQ2_9	Disabled	OK	None	None
<input type="checkbox"/> C4.10	RJ IQ 2	Pc 10: IQ2_10	Disabled	OK	None	None
<input type="checkbox"/> C4.11	RJ IQ 2	Pc 11: IQ2_11	Disabled	OK	None	None
<input type="checkbox"/> C4.12	RJ IQ 2	Pc 12: IQ2_12	Disabled	OK	None	None

Figure 30. Example Pump Controller Communications Screen

Display Options

Addresses for active and/ or configured pump controllers display by default. You can show all pump controller addresses by touching the Actions button, then Show All Addresses in the Actions pop-up box (see Figure 31).

Gauge Mapping	ATG Status	PC Status	Line	Pump
1: PC1	Idle	OK	Ln 1	Pm 1
2: PC2	Idle	OK	Ln 1	Pm 2
3: PC3	Idle	OK	Ln 2	Pm 3
4: PC4	Idle	OK	Ln 2	Pm 4
5: PC5	Idle	OK	Ln 3	Pm 5
6: PC6	Idle	OK	Ln 3	Pm 6

Figure 31. Displaying All Controller Addresses (Active and Configured)

Reset

In the Address column of the Pump Controller Diagnostics screen, touch the check box by the controller you want to reset (see Figure 30), then touch **Actions** to open the Actions box (see Figure 32). Touch Reset in the Actions pop up box, to reset pump controller. Note: This reset option is only available to Administrator Roles.

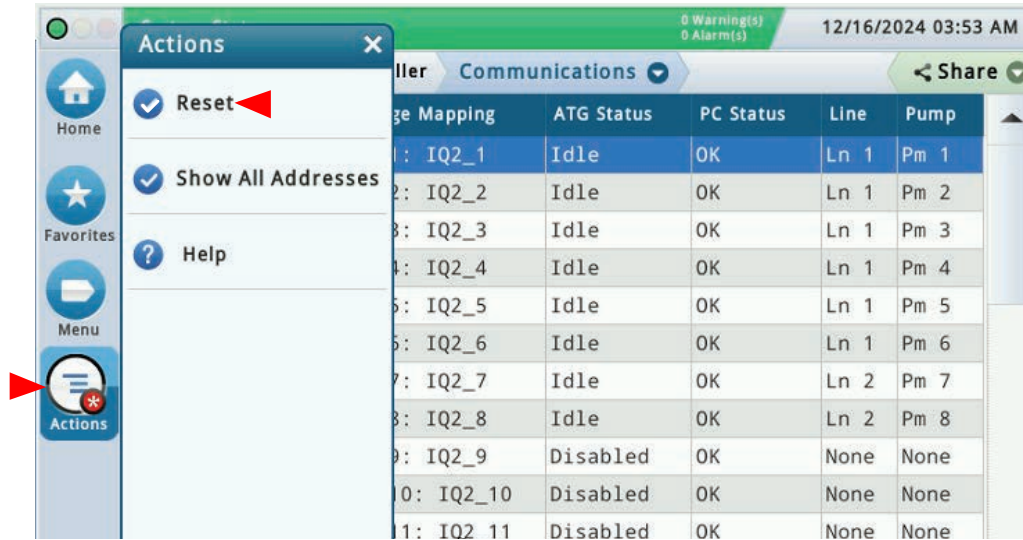

Figure 32. Resetting Controllers

! A manual reset is required at the physical pump controller if the Type is “unknown”, if a Comm Fault is active or if the pump controller doesn’t support it.

Pump Overview

This screen lets you view diagnostic and status information for pumps and pump controllers from the ATG and contains four areas of information; Pump, Pump Controller or Relay, Operations, and Settings.

With the desired pump selected, navigate to **Menu>Diagnostics>Pumps>Overview** (see Figure 33 and Figure 34). When viewing the Pump Overview screen, you can touch the **Actions>Help** icons to view Online Help for more information about the fields.



Figure 33. Example Pumps Overview Screen

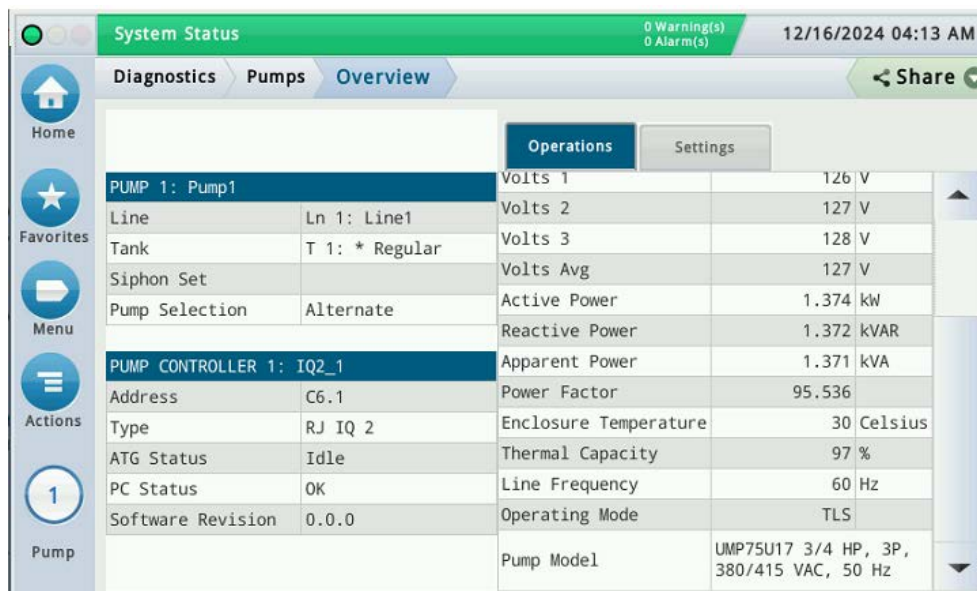

Figure 34. Example Pumps Overview Screen (Scrolled Down)

Statistical Reports

Hourly - Current Report

To view an Hourly generated report of pump run data for the selected Pump Controller, navigate to **Menu>Diagnostics>Pump Controller>Statistics** (see Figure 35 and Figure 36). Data is collected and posted each hour and displayed for a 24 hour period.

IQ2 Pump Controllers can be reported as 'helping' when they request help, or fail and need help from another pump. Pumps helping one another are shown as 'running'.

System Status		0 Warning(s) 0 Alarm(s)		09/15/2025 05:39 PM		
Diagnostics		Pump Controller		Statistics		
Timestamp	Running Count	Running Accum	Help Req Count	Help Req Accum	Fault Count	Fa Acc
09/15/2025 05:38 PM	0	00:00:00	0	00:00:00	0	00:00
09/15/2025 04:58 PM	0	00:00:00	0	00:00:00	0	00:00
09/15/2025 03:58 PM	0	00:00:00	0	00:00:00	0	00:00
09/15/2025 02:58 PM	0	00:00:00	0	00:00:00	0	00:00
09/15/2025 01:58 PM	0	00:00:00	0	00:00:00	0	00:00
09/15/2025 12:58 PM	0	00:00:00	0	00:00:00	0	00:00
09/15/2025 11:58 AM	0	00:00:00	0	00:00:00	0	00:00
09/15/2025 10:58 AM	0	00:00:00	0	00:00:00	0	00:00
09/15/2025 09:58 AM	0	00:00:00	0	00:00:00	0	00:00
09/15/2025 08:58 AM	0	00:00:00	0	00:00:00	0	00:00
09/15/2025 07:58 AM	0	00:00:00	0	00:00:00	0	00:00
09/15/2025 06:58 AM	0	00:00:00	0	00:00:00	0	00:00

Figure 35. Example Diagnostics Pump Controller Statistics Screen

System Status		0 Warning(s) 0 Alarm(s)		09/15/2025 05:40 PM		
Diagnostics		Pump Controller		Statistics		
Timestamp	ent um	Current Maximum	Current Average	Voltage Minimum	Voltage Maximum	Voltage Average
09/15/2025 05:38 PM	.00	75.54	11.00	0.00	256.61	210.61
09/15/2025 04:58 PM	.00	75.54	11.00	0.00	256.61	210.61
09/15/2025 03:58 PM	.00	75.54	11.00	0.00	256.61	210.61
09/15/2025 02:58 PM	.00	75.54	11.00	0.00	256.61	210.61
09/15/2025 01:58 PM	.00	75.54	11.00	0.00	256.61	210.61
09/15/2025 12:58 PM	.00	75.54	11.00	0.00	256.61	210.61
09/15/2025 11:58 AM	.00	75.54	11.00	0.00	256.61	210.61
09/15/2025 10:58 AM	.00	75.54	11.00	0.00	256.61	210.61
09/15/2025 09:58 AM	.00	75.54	11.00	0.00	256.61	210.61
09/15/2025 08:58 AM	.00	75.54	11.00	0.00	256.61	210.61
09/15/2025 07:58 AM	.00	75.54	11.00	0.00	256.61	210.61
09/15/2025 06:58 AM	.00	75.54	11.00	0.00	256.61	210.61

Figure 36. Example Diagnostics Pump Controller Statistics Screen (Scrolled to Right)

Historical - Accumulated Report

To view a Daily report of pump run data for the selected Pump Controller, navigate to **Menu>Reports>Pump Controller>Statistics** (see Figure 37 and Figure 38). This report is generated at midnight for the previous day.

Select the criteria to view:

- Pump Controller - Select IQ2 1 to 31
- Date - Select **Actions>Select Range** - Enter a date range for the data that you want displayed (the default is the last 7 days).

When viewing the screen, touch **Actions/Help** icons for descriptions of the Statistics report's column descriptions. Maximum and minimum voltages and currents are on a per phase basis and not an average of all the available phases.

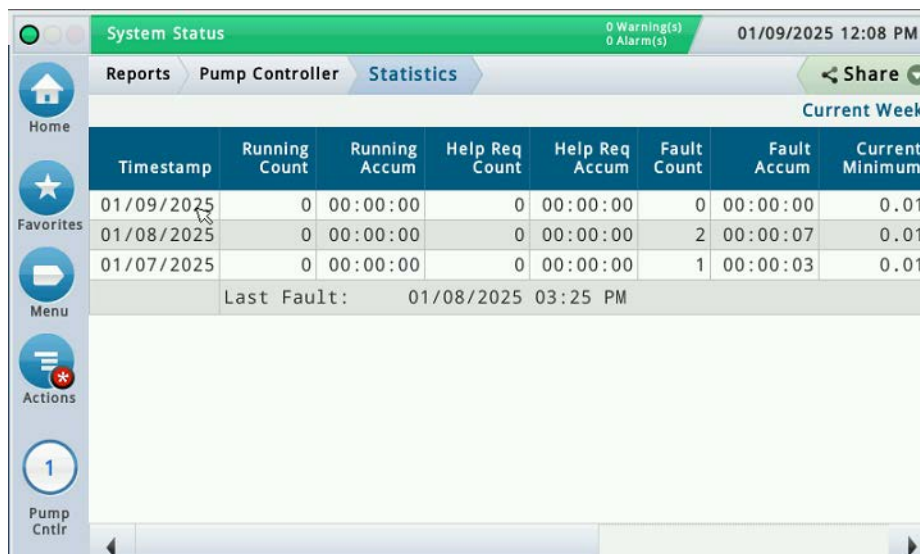

Figure 37. Example Reports Pump Controller Statistics Screen

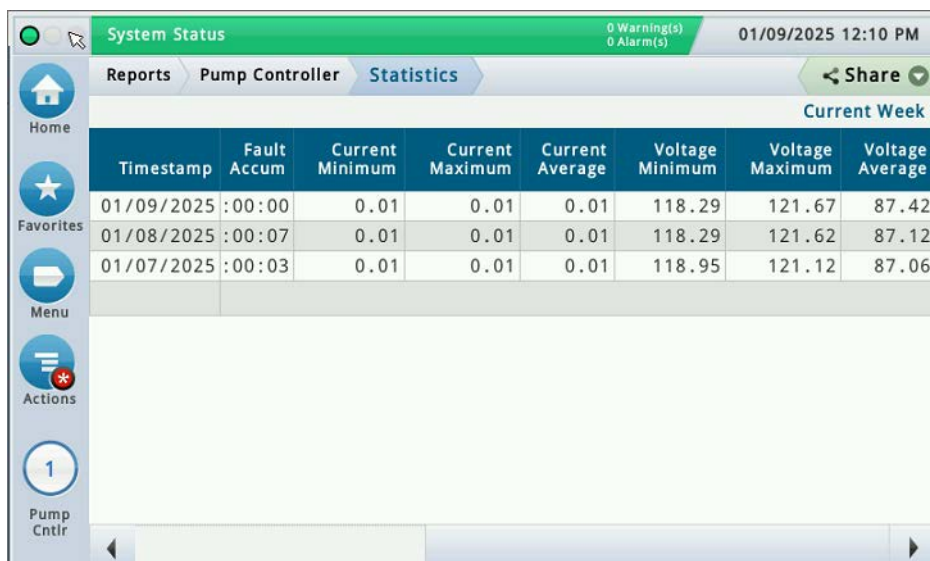

Figure 38. Example Reports Pump Controller Statistics Screen (Scrolled to Right)

Home and Clear Alarms Screen

The Home screen has a unique navigation structure that differs from any other menu. This screen displays an overview of the IQ2 status such as the configured pump model and the presence or absence of an alarm or warnings. There is a single screen, the Clear Alarms screen that is accessible from the Home screen only if there is an alarm or warning present (see Figure 40). All other screens are always available.

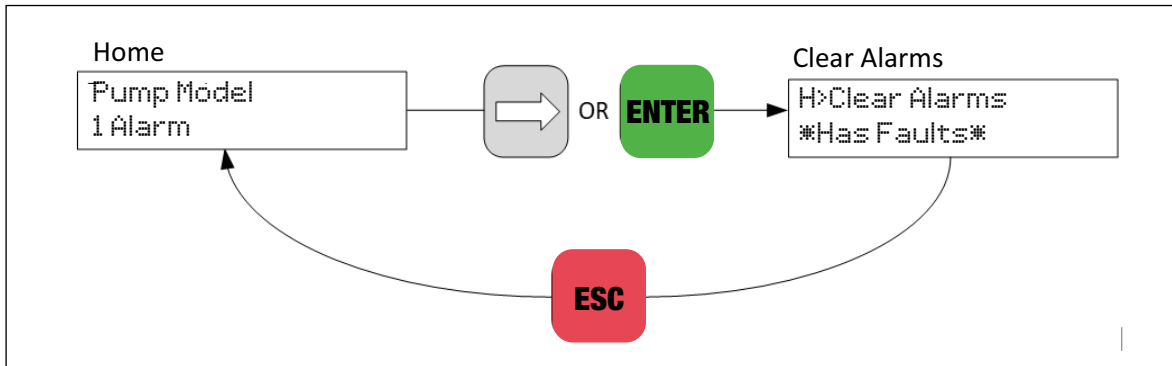

Figure 40. Alarms Menu

When accessible, the Clear Alarms screens will show one of two different messages. The first message indicates that there is an active alarm that can be cleared.

When a menu screen is displayed, the top line of text will be prefixed with a letter and a ">" to indicate which menu this screen is a part of. In the example above, the Home menu is being accessed and this is indicated by an "H".

The Clear Alarms screen indicates whether a fault is likely present or not. If a fault is present, the alarm clear functionality is inhibited. This is done to prevent re-energizing the pump onto a fault, likely causing the IQ2 to re-trip (see Figure 41).

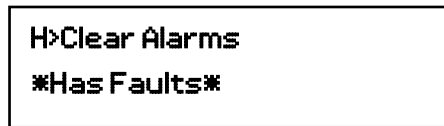

Figure 41. Clear Alarms Screen with Fault

If no faults are currently present, the following message is displayed on the Clear Alarms screen and pressing ENTER will clear all alarms and warnings (see Figure 42).

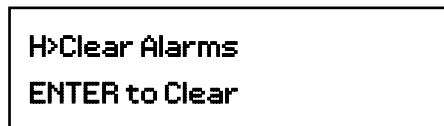

Figure 42. Clear Alarms Screen without Fault

Parameters Menus

The Parameters Menu displays the basic measured electrical parameters for the IQ2's attached pump. The Parameters Menu screens are accessed through the Parameters Menu root header as shown in Figure 43.

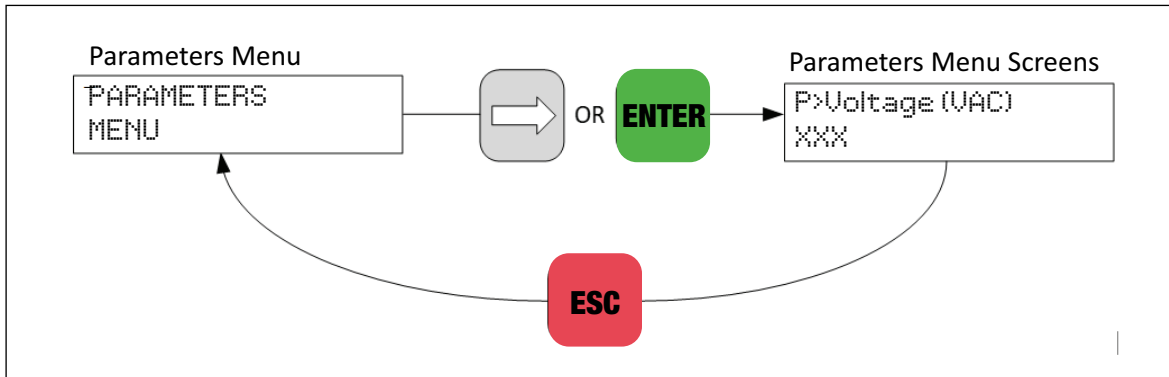

Figure 43. Parameters Menu Entry and Exit

All Parameters Menu screens contain a “P>” prefix on the top line of text to indicate that the screen is part of the Parameters Menu.

Once inside the Parameters Menu, the LEFT and RIGHT buttons can be used to traverse the various screens as shown in Figure 44.

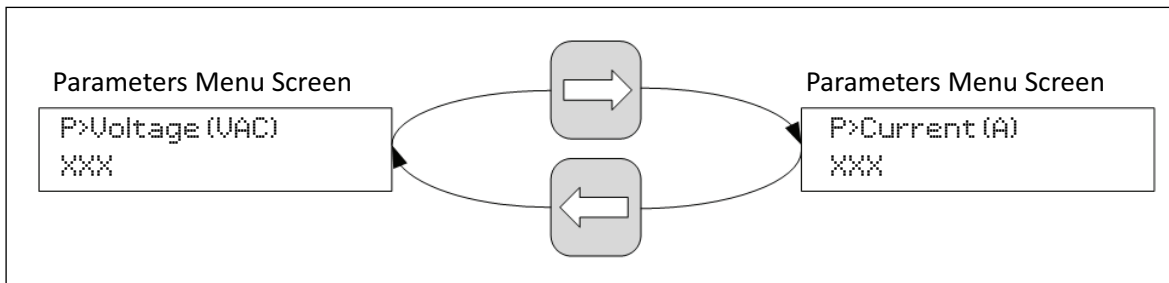

Figure 44. Parameters Menu Screen Navigation

Inside the Parameters Menu, the ESC button must be used to leave the menu. This is true for all menus. Once the last menu screen is reached, pressing the RIGHT button will no longer cause the menu screen to traverse to the next menu screen since there isn't one. The same behavior occurs for the first menu screen and the LEFT button. Menu navigation does not wrap-around.

The first to last sequence of the Parameters Menu screens is:

1. Voltage
2. Current
3. Active Power
4. Reactive Power
5. Apparent Power
6. Power Factor

The Parameters Menu screens are described in detail below.

Voltage Screen

The Voltage Screen displays the line-to-line voltage for each phase of incoming power that is provided to the pump. The units are in RMS Volts or equivalently Volts AC. The Voltage Screen has 2 variations; a single-phase variation (see Figure 45) and a three phase variation (see Figure 46).



```
P>Voltage (VAC)
240.0
```

Figure 45. Voltage Screen Single-Phase

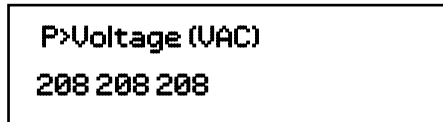

```
P>Voltage (VAC)
208 208 208
```

Figure 46. Voltage Screen Three-Phase

Current Screen

The Current Screen displays the current for each phase of incoming power that is provided to the pump. The units are in Amperes. The Current Screen has 2 variations; a single-phase variation (see Figure 47) and a three phase variation (see Figure 48).

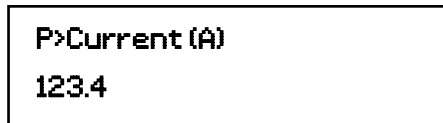

```
P>Current (A)
123.4
```

Figure 47. Current Screen Single-Phase

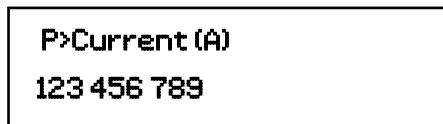

```
P>Current (A)
123 456 789
```

Figure 48. Current Screen Three-Phase

Active Power Screen

The Active Power Screen displays the total active power that is provided to the pump. The units are in kilowatts (see Figure 49).

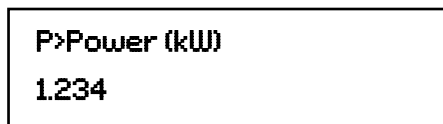

```
P>Power (kW)
1.234
```

Figure 49. Active Power Screen

Reactive Power Screen (VAR)

The Reactive Power Screen displays the total reactive power that is provided to the pump. The units are in kilovars (see Figure 50).



Figure 50. Reactive Power Screen

Apparent Power Screen (VA)

The Apparent Power Screen displays the total apparent power that is provided to the pump. The units are in kilovolt-amperes (see Figure 51).

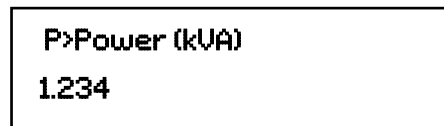

Figure 51. Apparent Power Screen

Power Factor Screen

The Power Factor Screen displays the average power factor for the power provided to the pump. Power factor has no units (see Figure 52). Power factor is one input the IQ2 uses to differentiate between a pump running with low flow (low power, higher power factor) vs. dry running (same low power, much lower power factor). A value >0.5 would be good.

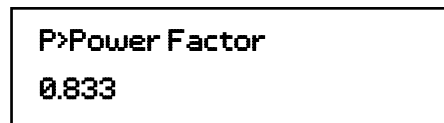

Figure 52. Power Factor Screen

Diagnostics Menu

The Diagnostics Menu is used to show IQ2 data that is not found in the Parameters Menu. The Diagnostics Menu screens are accessed through the Diagnostics Menu root header as shown in Figure 53.

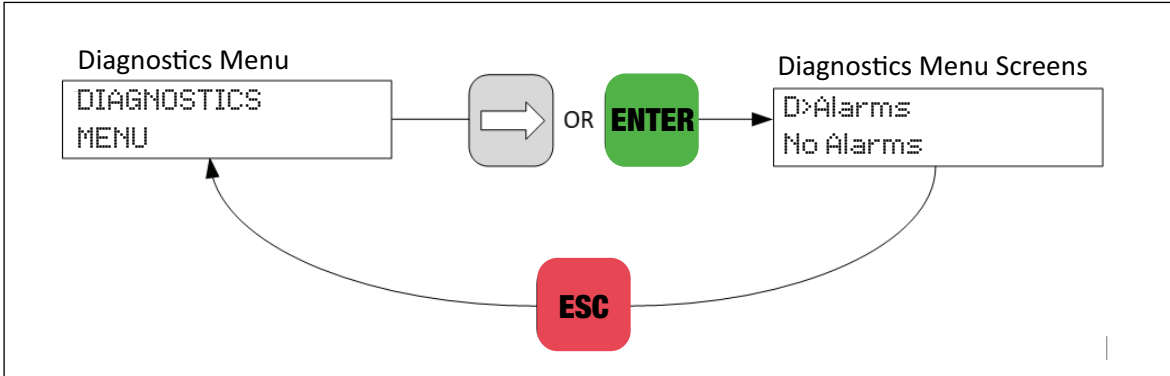

Figure 53. Diagnostics Menu Entry and Exit

All Diagnostics Menu screens contain a “D>” prefix on the top line of text to indicate that the screen is part of the Diagnostics Menu.

Once inside the Diagnostics Menu, the LEFT and RIGHT buttons can be used to traverse the various screens as shown in the following:

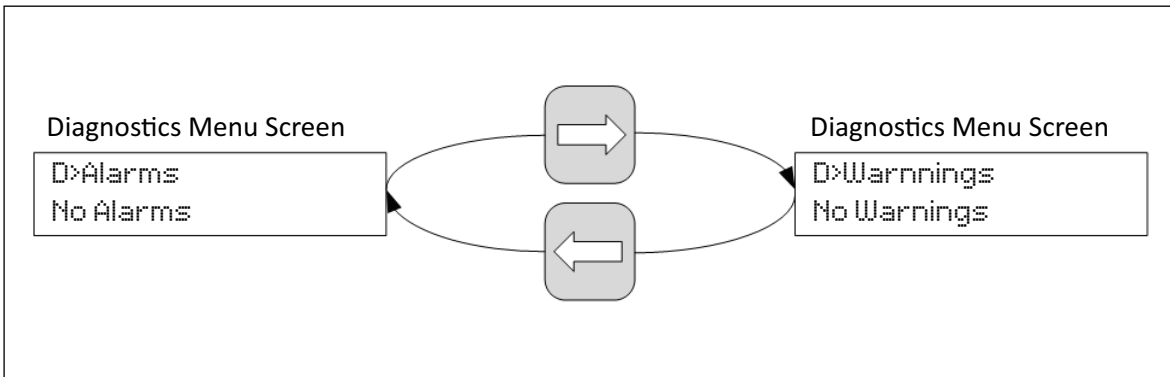

Figure 54. Diagnostics Menu Screen Navigation

Once inside the Diagnostics Menu, the ESC button must be used to leave the menu. This is true for all menus. Once the last menu screen is reached, pressing the RIGHT button will no longer cause the menu screen to traverse to the next menu since there isn’t one. Menu navigation does not wrap-around. The same behavior occurs for the first menu screen and the LEFT button.

The order of the Diagnostics Menu screens, from left to right, is:

1. Alarms
2. Warnings
3. Thermal Capacity

4. Enclosure Temperature
5. Help Value
6. Hook Switch
7. Contactor
8. Firmware Version
9. Hardware Version

The Diagnostics Menu screens are described in detail below.

Alarms

The Alarms Screen displays all active alarms. The display will scroll through all the active alarms, displaying the next active alarm after a 1 second delay. If there are no alarms, the Alarms Screen will appear as shown Figure 55. If there are any active Alarms, the number of Alarms will be indicated in the top line.

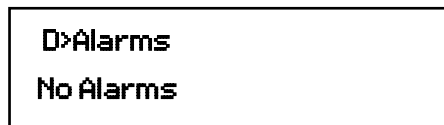

Figure 55. Alarms Screen without Alarms

Warnings

The Warnings Screen displays all active warnings. The display will scroll through all the active warnings, displaying the next active warning after a 1 second delay. If there are no warnings, the Warnings Screen will appear as shown in Figure 56. If there are any active Warnings, the number of Warnings will be indicated in the top line.

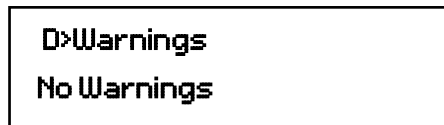

Figure 56. Warnings Screen without Alarms

Thermal Capacity

The Thermal Capacity Screen displays the thermal capacity that is monitored by the Overload Relay.

The Overload Relay allows the attached pump to run in an overloaded condition for a limited time period. The percentage displayed in the Thermal Capacity Screen represents how much of the overloaded condition has been consumed before the pump must be stopped to prevent damage. When the thermal capacity reaches 100%, the pump will be stopped due to an Overload Relay Alarm. The Overload Relay Alarm will be unable to be cleared unless the thermal capacity is at or below 80% (see example in Figure 57).

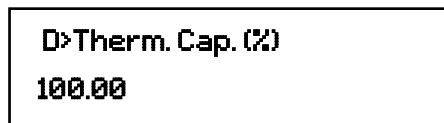
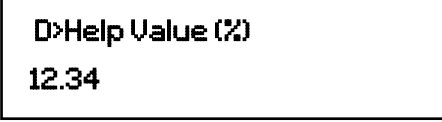

Figure 57. Thermal Capacity Screen

Help Value

The Help Value Screen displays the current percentage of the full flow available for the configured pump. When this value exceeds the configured Help Threshold for a pre-configured period of time, and there is another IQ2 controlled pump available on the manifold, the IQ2 will request an additional pump be started to satisfy the additional demand for flow. An example screen is shown in Figure 58.



```
D>Help Value (%)
12.34
```

Figure 58. Help Value Screen

Enclosure Temperature

The Enclosure Temperature Screen displays the temperature from an ambient temperature sensor located inside the IQ2 enclosure. An example screen is shown in Figure 59.

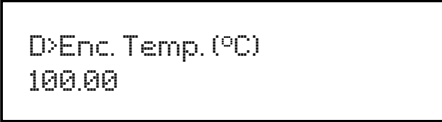

```
D>Enc. Temp. (°C)
100.00
```

Figure 59. Enclosure Temperature Screen

Hook Switch

The Hook Switch Screen displays the status of the IQ2 hook switch digital input. When the hook switch digital input is energized, the Hook Switch Screen appears as shown in Figure 60. When the hook switch digital input is de-energized, the Hook Switch Screen appears as shown in Figure 61.



```
D>Hook Switch
Off-Hook
```

Figure 60. Hook Switch Screen Off-Hook or Energized



```
D>Hook Switch
On-Hook
```

Figure 61. Hook Switch Screen On-Hook or De-Energized

Contactor

The Contactor Screen displays the commanded state of the IQ2 contactor. When the Contactor is open and the pump is de-energized, the Contactor Screen is as shown in Figure 62. When the Contactor is closed and the pump is energized, the Contactor Screen is as shown Figure 63.

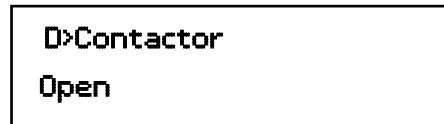

```
D>Contactor
Open
```

Figure 62. Contactor Screen Open (Pump De-Energized)

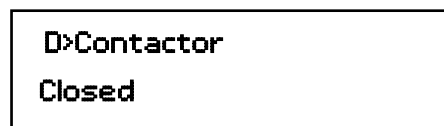

```
D>Contactor
Closed
```

Figure 63. Contactor Screen Closed (Pump Energized)

Firmware Version

The Firmware Version Screen displays the current firmware version of the IQ2. The number to the left of the "." is the firmware major version while the number to the right of the "." is the firmware minor version. An example screen is shown in Figure 64.



```
D>FW Version
1.23
```

Figure 64. Firmware Version Screen

Hardware Version

The Hardware Version Screen displays the current hardware version of the IQ2. The hardware version is a number between 0 and 15 inclusive. An example screen is shown in Figure 65.

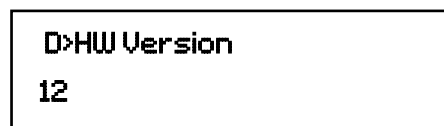

```
D>HW Version
12
```

Figure 65. Hardware Version Screen

Settings Menu

- The Settings Menu is used to edit the IQ2 configuration. The Settings Menu screens are accessed through the Settings Menu root header using the CONFIRM button combination as shown in Figure 66.

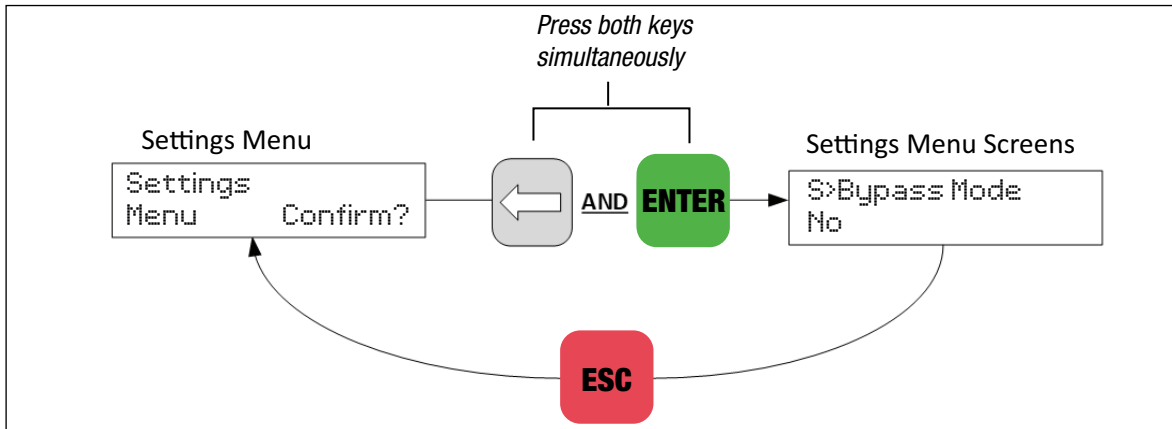

Figure 66. Settings Menu Entry and Exit

All Settings Menu screens contain an “S>” prefix on the top line of text to indicate that the screen is part of the Settings Menu.

Once inside the Settings Menu, the LEFT and RIGHT buttons can be used to traverse the various screens as shown in Figure 67.

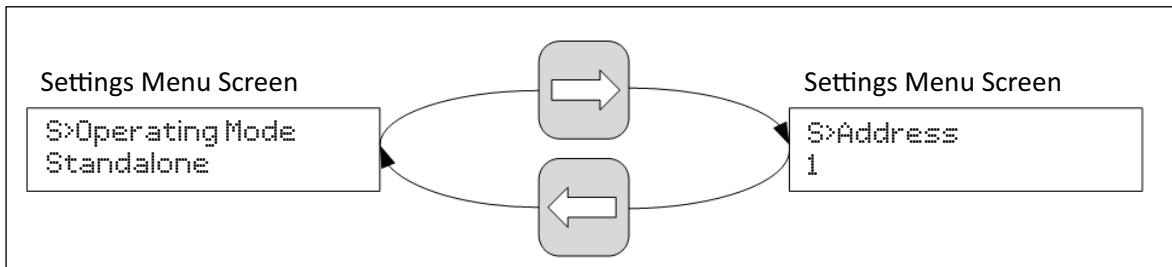

Figure 67. Settings Menu Screen Navigation

Once inside the Settings Menu, the ESC button must be used to leave the menu. This is true for all menus. Once the last menu screen is reached, pressing the RIGHT button will no longer cause the menu screen to traverse to the next menu since there isn't one. Menu navigation does not wrap-around. The same behavior occurs for the first menu screen and the LEFT button.

The order of the Settings Menu screens, from left to right, is:

1. Bypass Mode
2. Operating Mode
3. Address
4. Phases
5. Pump Model

6. Help Threshold
7. Extended Run Warning
8. Reboot
9. Download Firmware

The screens in the Settings Menu allow for configuration parameters to be viewed and edited or for special commands to be executed. A prefix is displayed in front of the parameter value displayed on the lower line of the display to indicate one of three possible states for the configuration parameter:

1. Display
2. Editing
3. Altered

When the configuration parameter is in the Display state, the front panel reflects the current value for the configuration parameter that is in use by the IQ2. The value cannot be changed while in this state and there is no prefix displayed as shown in Figure 68.



Figure 68. Operating Mode Screen Display State

By pressing the ENTER button while displaying a configuration parameter in the Display state, the configuration parameter enters the Editing state. The display indicates that the configuration parameter is in the Editing state by prefixing the parameter value displayed on the lower line of the display with ">" as shown in Figure 69.

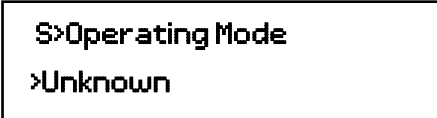

Figure 69. Operating Mode Screen Editing State

The configuration parameter can be changed by using the UP and DOWN buttons. To cancel the edit to the configuration parameter and keep the original value that was displayed, press the ESC button to revert to the Display state with the original unedited value for the configuration parameter. To apply the edited value for the configuration parameter, press the ENTER button.

By pressing the ENTER button, the configuration parameter will enter the Altered state. When in the altered state, the front panel indicates that the configuration parameter is in the Altered state by prefixing the parameter value displayed on the lower line of the display with "*" as shown in Figure 70.

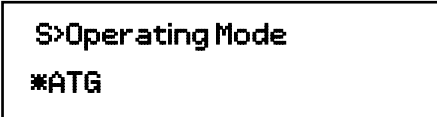

Figure 70. Operating Mode Screen Altered State

When a configuration parameter is in the Altered state, the configuration parameter has been committed to the configuration memory of the IQ2, but it has not taken affect. To make the updated configuration parameter active, the IQ2 must be rebooted or power cycled. See "Reboot" on page 48 for instructions on how to reboot the IQ2 without power-cycling.

The Settings Menu screens are described in detail in the following sections. Default values for settings will be prefixed with an “*”. A default IQ2 that has no configuration will power-on with the default settings for all configuration parameters.

Bypass Mode



WARNING! Bypass Mode is for diagnostic purposes only.

The Bypass Mode Screen displays and edits the current state of Bypass Mode. Bypass Mode allows the IQ2 to ignore any alarms and continue to operate as if there were no alarms present. This mode is useful for diagnosing and troubleshooting equipment failures.

The Bypass Mode configuration parameter can be one of the following values:

- Yes – Bypass Mode is enabled and Alarms do not prevent the pump from starting
- No - Bypass Mode is disabled and Alarms stop the pump and prevent the pump from restarting

The Bypass Mode configuration parameter takes effect immediately and does not require a reboot. When Editing the Bypass Mode configuration parameter, pressing ENTER will immediately apply the indicated setting. The Bypass Mode configuration parameter is not retained by the IQ2 and will always revert to “No” when the IQ2 is powered-on.

Bypass Mode may be set to “Yes” for up to 15 minutes. After 15 minutes have elapsed, Bypass Mode will automatically switch to a “No” setting.

If there is an active IQ2 alarm while Bypass Mode is set to “Yes”, and the contactor is closed, setting Bypass Mode to “No” will cause the contactor to immediately open.

Operating Mode

The Operating Mode Screen displays and edits the current state of the Operating Mode. The Operating Mode determines what application the IQ2 is installed into and how the IQ2 is controlled.

The Operating Mode configuration parameter can be one of the following values:

- Unknown - Default value, not available after any other configuration is applied
- Standalone – A single IQ2 controlled by the hook switch input
- Direct – A manifold set of IQ2's controlled by the hook-switch input and a P2P Network; the lowest addressed IQ2 always starts first
- Sequential – A manifold set of IQ2's controlled by the hook-switch input and a P2P Network; the IQ2 that starts first will rotate amongst the available IQ2's.
- ATG – An IQ2 connected to a MODBUS network containing a single ATG for control

A valid setup must have an Operating Mode that is not set to “Unknown”.

Address

The Address Screen displays and edits the current state of the Address. The Address uniquely identifies the IQ2 on a network, regardless of the network type.

The Address configuration parameter is a value between 1 and 8 inclusive with *0 being the default value for a P2P network. The Address configuration parameter is a value between 1 and 31 inclusive with 0 being the default value for a MODBUS network.

A valid setup must have an Address that is not set to 0 for anything but the Standalone Operating Mode.

Phases

The Phases Screen displays and edits the current state of the number of electrical phases for the pump model. The Phases configuration parameter is used to filter the list of Pump Models to only those Pump Models that match the number of Phases.

The Phases configuration parameter can be one of the following values:

- *Unknown – No Phases is configured
- 1 – The Pump Model list is filtered to only show single-phase pumps
- 3 - The Pump Model list is filtered to only show three-phase pumps

A valid setup implies that a Phases is not set to “Unknown” or else a Pump Model cannot be configured.

Pump Model

The Pump Model Screen displays all supported pumps that the IQ2 can be configured for, filtered by the Phases configuration parameter. The Phases configuration parameter is used to filter the list of Pump Models to only those Pump Models that match the number of Phases.

The default Pump Models configuration parameter value is “Unknown”. The available Pump Models will vary – refer to Appendix A for a complete list of supported Pump Models for a particular version of firmware.

For the IQ2 to function properly, the Pump Model must be set to the corresponding pump model that the IQ2 is controlling.

A valid setup must have a Pump Model that is not set to “Unknown”.

Help Threshold

The Help Threshold Screen displays and edits the current setting for the Help Threshold. The Help Threshold is the value at which this IQ2 will request additional pumps be turned on to satisfy the demand for flow. This setting can be adjusted anywhere between 50 and 95% to tailor the Help Mode feature.

As more nozzles are opened at more fueling positions on a single manifold, the flow to each nozzle position will eventually lessen as the pumping capacity of a single pump is reached. Adding additional pumps, operating in parallel on the same manifold, can maintain the same flow at each fueling position. The Help Threshold is used to tailor when additional pumps are started, based on the specifics of the site installation and the goals of how the site should be operated.

A lower value for the Help Threshold will result in additional pumps starting at lower flow rates. A higher value for the Help Threshold will not start additional pumps until the current pump is closer to its maximum flow rate. Sites with more restrictive piping installations or with higher flow demands may want to reduce the Help Threshold from its default setting. Sites wishing to consume less power at the potential expense of lower flow rates or incur less wear on the pumps may want to increase the Help Threshold from its default setting.

Extended Run Warning

The Extended Run Warning Screen displays and edits the Extended Run Warning time in hours. The value of the Extended Run Warning time can be DISABLED by setting the time to 0. When The time is set to 0, DISABLED will be displayed on the screen . Any settings above 0, and up to 255 hours, will display the configured time in hours (see Figure 71).

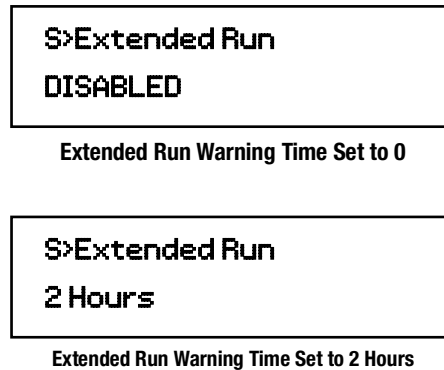

Figure 71. Extended Run Warning Screen Examples

Reboot

The Reboot Screen is used to reboot the IQ2 without having to cycle power to the IQ2 (see Figure 72).

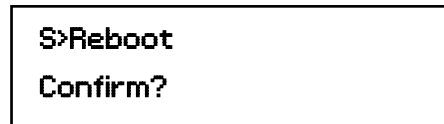

Figure 72. Reboot Screen

To reboot the IQ2, press the CONFIRM button sequence, consisting of LEFT and ENTER simultaneously. The IQ2 will immediately reboot.

Download Firmware

The Download Firmware Screen is used to start the IQ2 bootloader (see Figure 73). The IQ2 bootloader is an alternate IQ2 application that allows for firmware to be downloaded to the IQ2. See "Firmware Update" on page 58, for more details.

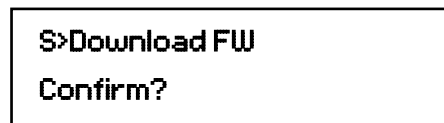

Figure 73. Download Firmware Screen

To download firmware to the IQ2, press the CONFIRM button sequence, consisting of LEFT and ENTER simultaneously. The IQ2 will immediately start the bootloader and be awaiting a firmware update. Note that the pump will not operate in firmware download mode and the IQ2 must be power cycled to return the IQ2 to normal operation.

Other Screens

There are several additional IQ2 display screens that may appear without any operator intervention.

Power Lost

The Power Lost Screen is displayed when the IQ2 has lost incoming power (see Figure 74)



Figure 74. Power Lost Screen

When this screen is displayed, the IQ2 is operating off the holdup capacity of the control power supply and is continuing to operate normally. The amount of holdup time varies with the voltage of the power source that was supplied to the IQ2 and may exceed 10 seconds.

In this holdup state, the IQ2 is inhibited from displaying any warnings or alarms, though a network connected ATG may pick up an alarm before the IQ2 drops off of the network.

Error

The Error Screen is displayed when the IQ2 has encountered an error and cannot continue operating (see Figure 75).

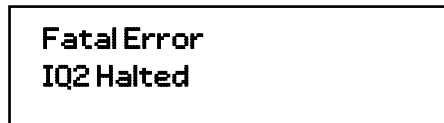

Figure 75. Error Screen

When this screen is displayed, the IQ2 has suffered an error that prevents the IQ2 from continuing to operate while providing protection to the attached pump. The IQ2 should reboot within a second and should continue to operate, if possible, without any further interaction.

This sort of error is typically caused by an issue with the IQ2 firmware, or a transient hardware issue. If a hardware failure has occurred, the IQ2 will likely continue to encounter the error and reboot until it is powered off.

Alarms and Warnings

The IQ2 can generate both Alarms and Warnings in response to various conditions to protect the pump. An Alarm is a more serious condition that likely requires a direct intervention to resolve and stops the pump from operating. A Warning is a less serious condition that does not prevent the pump from operating. The information required to parameterize the IQ2 to generate Alarms and Warnings is unique to the pump that the IQ2 is controlling. Selecting the matching pump model is required to ensure proper pump protection.

When an Alarm occurs, the pump will immediately stop if it was running and be prevented from restarting until the Alarm is manually cleared using the front panel. If the fault that created the Alarm is still present and has not been corrected, the Alarm cannot be cleared. This is to prevent pump damage by starting a pump into a fault condition. A fault is any condition that is detected by the IQ2 and used to take a protective action, such as signaling an Alarm or a Warning.

When a Warning occurs, the pump can continue to run. If the fault that created the Warning is still present and has not been corrected, the Warning cannot be cleared.

If both Alarms and Warnings are present, the Alarm will take priority. An Alarm will be indicated by the ERROR light, and the pump will be stopped.

Alarms

High Current Alarm

The High Current or Overcurrent Alarm is based on a time-overcurrent relay that monitors the average pump current to drive a thermal model of the pump motor. This thermal model allows the pump motor to withstand short time overloads that the pump motor may experience in normal operation, but that will not reduce the pump's lifespan. The maximum trip time for an overcurrent condition is limited to 3 hours.

The IQ2 implements a Class 10 trip curve having an extremely inverse shape (see Figure 76). This trip class is best suited for the submersible turbine pumps that the IQ2 controls and will trip at 600% FLA in approximately 10 seconds.

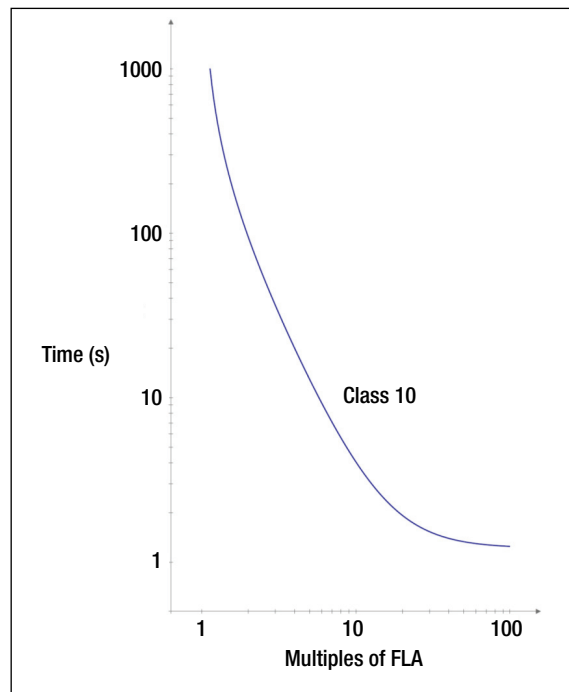

Figure 76. IQ2 Class 10 Inverse Trip Curve

Locked Rotor Alarm

The Locked Rotor Alarm uses an instantaneous overcurrent relay monitoring the average pump motor current to quickly trip a pump motor that has become jammed or locked due to a mechanical issue with the pump. This effectively creates an upper threshold at which the pump is prevented from operating without waiting for the time-overcurrent relay to generate a High Current Alarm.

During a locked rotor condition, the pump motor will draw the most current that it possibly can, quickly leading to pump damage due to overheating. This alarm prevents this condition from causing any pump damage.

High Voltage Alarm

The High Voltage Alarm uses a time-over voltage relay to monitor the average voltage supplied to the pump motor. This alarm will trip the pump motor if the supply voltage exceeds the expected supply voltage range for a significant period of time.

This condition may occur when an incorrect installation of the pump occurs or if a significant disturbance is experienced with the electrical grid or generator power supplying power to the pump motor.

Phase Loss Alarm

The Phase Loss Alarm uses two separate relays to detect the loss of a single power phase between the incoming IQ2 controller power and the controller pump.

The first detection method is a time-undervoltage relay operating on each phase of incoming power to the IQ2. This relay will detect if any incoming voltage phases are missing. In practice, only the loss of Phase C can be detected because the IQ2 derives control power from Phases A and B (Phase AB). The loss of either Phase A or Phase B will prevent the IQ2 from powering on and will also prevent the pump from running. This effectively provides pump motor protection due to the loss of any phase of incoming voltage. This detection method is only effective for incoming power to the IQ2 and cannot detect a missing phase between the IQ2 and the pump.

The second detection method is a time-undercurrent relay operating on each phase of power to the pump motor. This detection method is inactive if the contactor is not closed. Therefore, if there is a phase of power that is not connected between the pump and the IQ2, it cannot be detected until the contactor closed and the pump is attempted to be operated. This relay will detect the loss of a phase between the IQ2 and the pump motor, such as a missing connection, and stop the pump from operating with any missing phases.

Self-Test Alarm

The Self-Test Alarm monitors several internal aspects of the IQ2 that are critical to providing effective protection of the connected pump. If at any point there is any detected loss in protection, the Self-Test Alarm will occur along with a diagnostic code indicating the source of the alarm. Contact Veeder-Root Technical Support should this occur.

Network Alarm

A Network Alarm is caused by any loss in a network connection that was previously established. The network loss can be manifested in several ways including a timeout in receiving messages or too many messages that had detectable errors when received. A Network Alarm may occur until after successful network connection has first been made after the IQ2 has been powered-on.

Dry Run Alarm

A Dry Run Alarm is caused by the IQ2 detecting that the pump is attempting to operate when no fluid is present.

Warnings

Bypass Mode Warning

The Bypass Mode Warning occurs whenever Bypass Mode is enabled. Bypass Mode must be disabled to clear the Bypass Mode Warning.

Low Voltage Warning

The Low Voltage Warning uses a time-undervoltage relay to monitor the average voltage supplied to the pump motor. This warning will occur if the supply voltage is below the expected supply voltage range for a significant period of time.

This condition may be an indication of issues with the power supply to the pump that may warrant further investigation. A low voltage condition will generally not harm a pump motor. If the voltage is low enough, the pump motor will draw more current and the High Current Alarm will protect the pump motor from damage.

Open Circuit Warning

An Open Circuit Warning monitors the average current to the pump motor to determine if the pump motor is connected. This varies from a Phase Loss Alarm in that only the average current is monitored and a significantly lower threshold is used. Since this protection feature is current based, it cannot detect a missing pump motor connection until an attempt is made to operate the pump.

Over Temperature Warning

The Over Temperature Warning asserts whenever the temperature inside the IQ2 enclosure exceeds 65 °C (149°F) for a minute or longer. This in and of itself is not a cause for stopping the pump, but it is an indication of a potential environmental fault that has caused the IQ2 to exceed its rated operating environment.

Setup Data Warning

A Setup Data Warning occurs when the IQ2 is insufficiently configured to operate. See Alarms and Warnings on page 50 for details on what is required. If the IQ2 is insufficiently configured, it will be unable to operate. Since the IQ2 cannot operate the pump in this state, an alarm is not needed to prevent the pump from operating.

Extended Run Warning

An Extended Run Warning occurs when a contactor has been closed for 1 to 255 hours or longer, depending on its configuration. The Extended Run Warning can also be disabled. This is not necessarily an indication of any sort of a problem.

Troubleshooting

Alarms and Warnings

Alarms and warnings can be generated by faults reported by the pump controller as well as conditions reported by the IQ2.

Line shutdowns for faults can be set in Automatic Events.

Site Shutdown Detect in **Setup > System > Alarm Filtering** can be used to suppress Communication alarms (PC Comm Fault) when the site is shut down (e.g., at night) since the alarm is only active because of the shutdown process. Communication alarms that were active before the shutdown process began persist when the site reopens.

Table 4. ATG System Alarm

Alarm	Active When	Clears When
PC Address 0 Found	Pump Controller assigned an invalid address of 0.	No Pump Controllers are assigned to address 0.

Table 5. ATG Line Setup Data Warnings

Setup Data Warning	Active When	Clears When
Primary/Secondary Not Supported By Dispense Mode	Dispense Mode is All Pumps, Pump Sense, or Standard and a pump is configured as a Primary.	Dispense mode is not All Pumps, Pump Sense, nor Standard, or there is no configured pump as Primary.
In-Tank Staging Needs More Than 1 Pump In a Tank	In-Tank Staging is Enabled and there are not at least 2 pumps in 1 tank or siphon manifold set.	In-Tank Staging is Disabled or there are at least 2 pumps in 1 tank or siphon manifold set.
Across-Tank Staging Needs More Than 1 Tank	Across-Tank Staging is Enabled and there is not at least 1 pump in 2 non-siphon manifolded tanks.	Across-Tank Staging is Disabled or there is at least 1 pump in 2 non-siphon manifolded tanks.
Staging Not Supported By Dispense Mode	Dispense Mode is All Pumps, Pump Sense, or Standard and In-Tank Staging is Enabled or Across-Tank Staging is Enabled.	Dispense Mode is not All Pumps Pump Sense, nor Standard, or In-Tank Staging and Across-Tank Staging are Disabled.
Staging Not Supported With All Relays	In-Tank or Across-Tank Staging is Enabled and all pumps have relays.	In-Tank and Across-Tank Staging are Disabled or at least one pump has a Pump Controller.
Relay Controlled Pumps Cannot Be Primary	There is at least 1 pump with a relay configured as Primary.	There are no pumps with a relay configured as Primary.
More Than One Primary Pump In Tank Group	There is more than one Primary pump in a tank/siphon.	There is one or no Primary pump in all tank/siphon sets.
Dispense Mode Needs More Than 1 Tank	Dispense Mode is Alternate by Volume, Alternate by Height or Sequential and there is not at least 1 pump in 2 non-siphon manifolded tanks.	Dispense Mode is not Alternate by Volume, Alternate by Height or Sequential or there is at least 1 pump in 2 non-siphon manifolded tanks.

Table 6. ATG Line Alarms

Alarm	Active When	Clears When
Setup Data Warning	Setup Data Warning detected - see Table 5.	Setup Data Warning clears - see Table 5.
Line Out	There is a Pump Out alarm or a Pump Disabled alarm for all pumps on the line.	The Pump Out alarm or a Pump Disabled alarm for one of the pumps on the line clears.
	The line is disabled by an auto event.	The auto event causing the line to be disabled clears.
	Dispense Mode is Alternate by Volume, Alternate by Height, Sequential, or Alternate by Pump and is at least one pump with a Pump Out or Pump Disabled alarm in a tank that is over the backfill volume limit.	Dispense Mode is Alternate by Volume, Alternate by Height, Sequential, or Alternate by Pump and all tanks are under the backfill volume limit.
	Leak Monitoring is set to Monitoring PLLD and there is a PLLD Shutdown Alarm.	Leak Monitoring is set to Monitoring PLLD and the PLLD Shutdown Alarm clears.
	Leak Monitoring is set to Monitoring PLLD and there is a Communication Alarm for the assigned Pressure Sensor.	Leak Monitoring is set to Monitoring PLLD and the Communication Alarm for the assigned Pressure Sensor clears.
	Leak Monitoring is set to Monitoring PLLD and there is a Pump Out alarm or Pump Disabled alarm for the PLLD Controlling pump.	Leak Monitoring is set to Monitoring PLLD and the Pump Out alarm or Pump Disabled alarm for the PLLD Controlling pump clears.
No Backfill Protect	Dispense Mode is Alternate by Volume, Alternate by Height, Sequential, or Alternate by Pump and there is a Probe Out alarm in a tank on the line.	Dispense Mode is not Alternate by Volume, Alternate by Height, Sequential, or Alternate by Pump, or there is not a Probe Out alarm in a tank on the line.

Table 7. ATG Pump Alarm

Setup Data Warning	Active When	Clears When
Pump Disabled	Pump is disabled by an automatic event.	Pump is not disabled by an automatic event.

Table 8. ATG Pump Controller Setup Data Warning

Setup Data Warning	Active When	Clears When
Setup Data Warning	The pump controller is not assigned to a pump.	The pump controller is assigned to a pump.

Table 9. ATG Pump Controller Alarms

Alarm	Active When	Clears When
Setup Data Warning	Setup Data Warning detected - see Table 8.	Setup Data Warning clears - see Table 8.
Comm Out Alarm	More than 16 timeouts	Reply received.
Comm Error Fault	More than 16 LRC errors in a row	Reply received with valid LRC.

Table 9. ATG Pump Controller Alarms

Alarm	Active When	Clears When
PC Setup Data Warning	IQ2 has an active Setup Data warning.	Cleared on the IQ2 via the front panel.
Dry Run	IQ2 has an active Dry-Run alarm.	
Under Voltage	IQ2 has an active Low Voltage warning.	
Locked Rotor	IQ2 has an active Locked Rotor alarm.	
Open Circuit	IQ2 has an active Open Circuit warning.	
High Temperature	IQ2 has an active Over Temperature warning.	
Extended Run	IQ2 has an active Extended Run warning.	
Over Voltage	IQ2 has an active High Voltage alarm.	
Phase Loss	IQ2 has an active Phase Loss alarm.	
Overload	IQ2 has an active High Current alarm.	
Bypassed	IQ2 has an active Bypass Mode warning.	
Self Test	IQ2 has an active Self-Test alarm.	

Table 10. IQ2 Pump Controller Alarms

Alarm	Description	Possible Causes
High Current	An overload condition was detected for too long.	The pump inlet may be blocked. The pump may have a mechanical failure, such as a faulty bearing.
Locked Rotor	A severe overload was detected	The pump is unable to rotate (locked)
High Voltage	An over voltage condition was detected for too long	Incorrect power is connected to the pump.
Phase Loss	Current in at least one phase of power was lost	A wire is not properly connected to the power supply. A wire is not properly connected to the pump. The pump may have an internal electrical fault.
Self-Test	The continuous self-test encountered a fault	Damage to the IQ2
Network	A network fault occurred	Another IQ2 with the same address. If in ATG Operating Mode, the ATG is not communicating.
Dry-Run	A dry-run was detected	The fuel level has dropped below the pump inlet.

Table 11. IQ2 Pump Controller Warnings

Alarm	Description	Possible Causes
Bypass Mode	The IQ2 can run the pump without any protection.	The IQ2 has been put in this mode for troubleshooting by a qualified field service technician.
Low Voltage	Inadequate voltage is detected for too long.	Power supply droop caused by large loads nearby. Overloaded distribution transformer.
Open Circuit	There is no electrical connection to the pump.	No pump is connected to the IQ2. The pump may have an internal wiring fault.
Over Temperature	The IQ2 internal temperature is too high.	The IQ2 is in a location that is too hot.
Setup Data	IQ2 setup is incomplete.	The IQ2 setup is missing one or more parameters.
Extended Run	The IQ2 has run the pump continuously for more than 3 hours.	A hook signal that is stuck on. No cause, the site is very busy.

Firmware Update

Firmware Version

To check the firmware version installed on an IQ2, perform the following procedure.

Navigate through the IQ2 menus as follows, starting at the Home screen. Press ESC until the Home screen is displayed (see Figure 77).

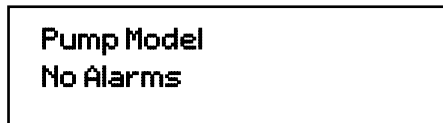

```
Pump Model
No Alarms
```

Figure 77. Home Screen

Navigate from the Home screen to the Diagnostics Menu by pressing the Down Arrow 2 times (see Figure 78).

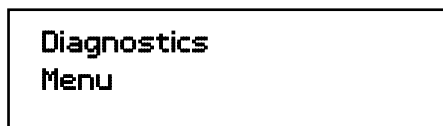

```
Diagnostics
Menu
```

Figure 78. Diagnostics Menu Screen

Press the ENTER button to enter the Diagnostics Menu (see Figure 79).

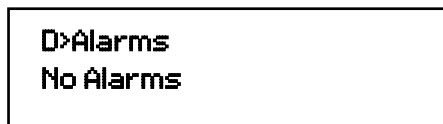

```
D>Alarms
No Alarms
```

Figure 79. Alarms Screen

The "D>" prefix on the top line indicates that the Diagnostics Menu has been entered. Other menus carry different prefixes to distinguish which menu has been entered and is active.

Press the Right Arrow 7 times to get to the Firmware Version screen (example firmware version may be different).



```
D>FW Version
1.23
```

Figure 80. Firmware Version Screen

The second line of the display indicates the full firmware version number.

Firmware Update

To obtain new firmware for the IQ2, contact Red Jacket Technical Support for the executable firmware downloader. The firmware for the IQ2 is part number 0349904-001 and will consist of a single zip file with a filename that corresponds to the firmware version. For example, a firmware file with the name of "349904-001-v.1.00.zip" will contain IQ2 firmware version 1.00. The firmware version number will appear between the "v." and ".zip" in the filename. The firmware version displayed on the HMI will match this firmware version number once the IQ2 has been updated with the new firmware.

To install the firmware, the zip file must first be extracted. A single executable file, with a ".exe" extension is in the zip file. The executable file will also have a filename that corresponds to the firmware version. For example, an executable file with the name of "IQ2 Production Firmware v. 1.00.exe" will contain IQ2 firmware version 1.00.

Connect a USB-C cable between the IQ2's USB-C port located on the bottom of the IQ2 enclosure and the laptop that will be used to run the firmware update (see Figure 81).

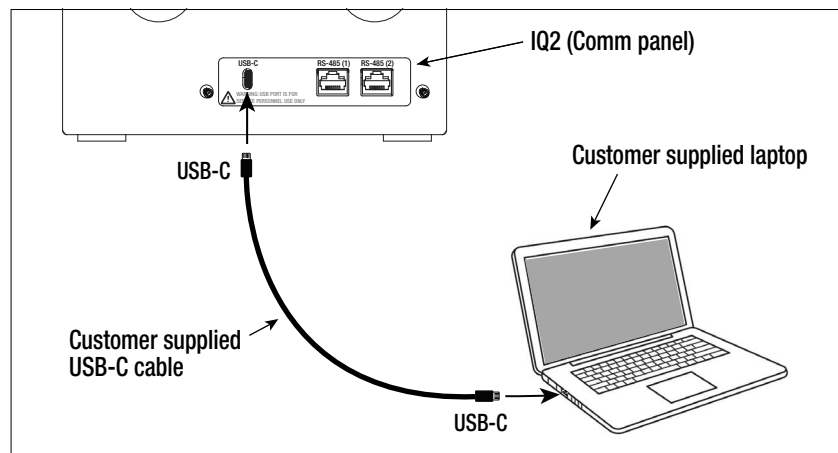

Figure 81. Connecting Laptop to IQ2 Comm Panel

Place the IQ2 into firmware download mode (reference "Download Firmware" on page 48).

Run the executable firmware downloader by either double-clicking on the executable file or running it in a command prompt. On some computers, a Windows Defender SmartScreen window may appear such as the one displayed below:

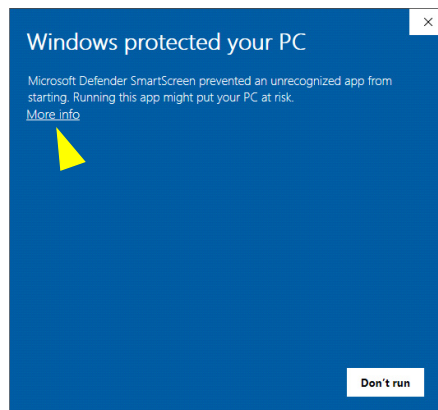

Figure 82. Windows Defender SmartScreen

To continue to run the firmware downloader, select “More info” and then click the “Run anyway” button that appears.

The firmware download will take approximately 15 seconds and the IQ2 will automatically reboot and start running the new firmware (see Figure 83).

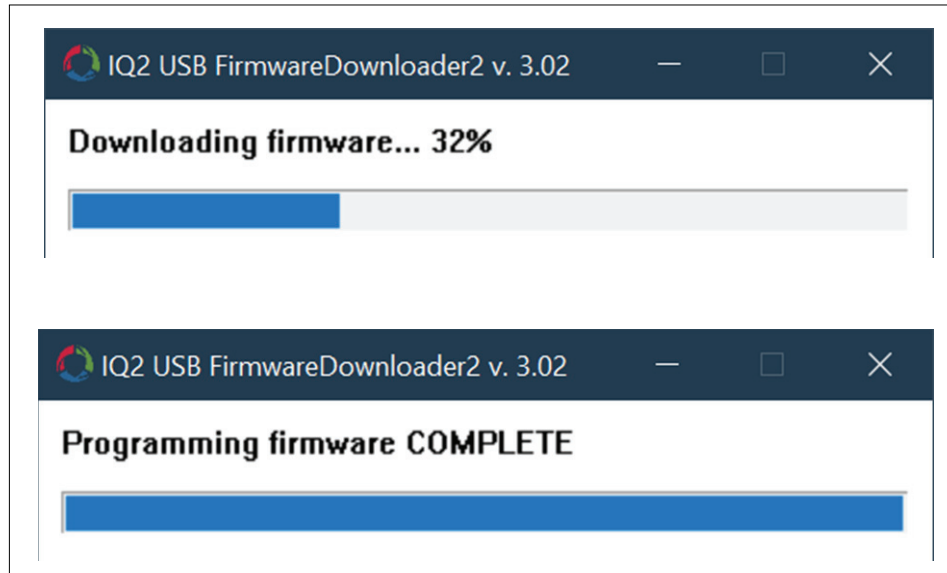

Figure 83. IQ2 Firmware Downloading Sequence Example

If there is an issue, the firmware downloader will display a message indicating that it was unable to download firmware and it will run for only about 1 second (see Figure 84). If there is an issue, verify that the USB-C cable is properly connected and that the computer recognizes the IQ2 when placed into firmware download mode. This is typically accompanied by a sound indicating that a USB connection has been made.



It is important to use a quality USB-C cable that supports at least the USB 2.0 standard as a minimum. These may be labeled as USB-C 2.0. There are USB-C cables that support charging only and they are not suitable to use with the IQ2 for firmware downloads. It is also recommended that a quality USB-C cable be used for reliability. If the computer does not recognize the IQ2, it is most likely due to a USB-C cable that is damaged or is the wrong kind or the IQ2 is not in firmware download mode.

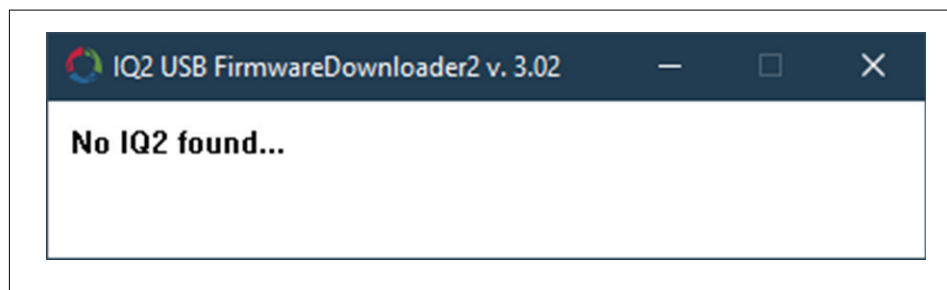

Figure 84. IQ2 Firmware Download Error Example

Firmware Update Driver

One issue that may prevent a successful firmware download is the presence of an older device driver that may prevent the successful use of the IQ2 firmware downloader.

To determine if this is the cause, first place the IQ2 into firmware download mode (reference “Download Firmware” on page 48). Then open the Windows Device Manager by pressing the Windows key [Example Windows Key] and typing “device manager” followed by **Enter** (see Figure 85):

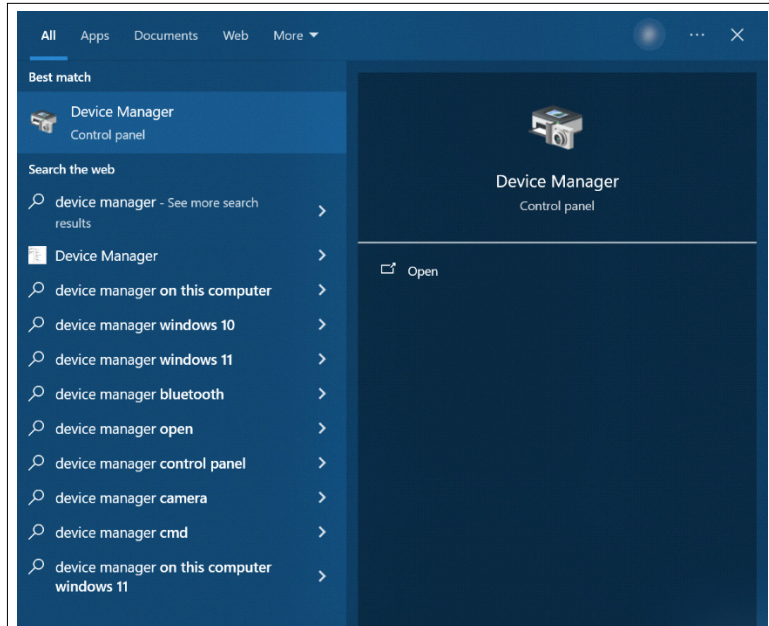

Figure 85. Accessing Device Manager

Find the device “STM Device in DFU Mode” in the list under “Universal Serial Bus controllers” (see Figure 86):

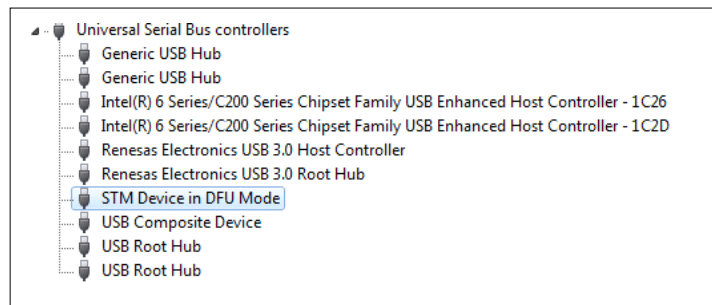

Figure 86. USB Controller Window Example

Right-click on the “STM Device in DFU Mode” device and select “Uninstall device”. Make sure that the option to “Delete the driver software for this device.” Is selected and then press **OK** (see Figure 87). This will remove the older device driver.

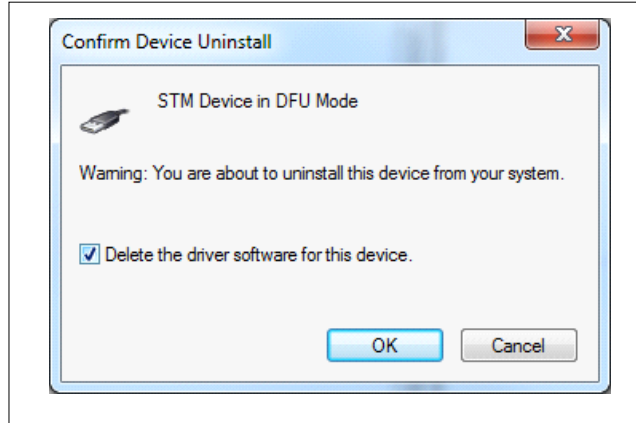

Figure 87. Confirm Device Uninstall Window

To install the required device driver, obtain the IQ2 Driver Software from <https://www.veeder.com/us/software-downloads>. Make note of where the file is downloaded to and browse to that location with a File Explorer.

Right-click on the downloaded IQ2 driver software archive and select “Extract All...” from the context menu. This will unzip the driver installation archive into the download location so that it can be installed. Finally, double-click on the newly created IQ2 driver software folder to show the contents of the archive (see Figure 88).

Name	Date modified	Type	Size
Driver	5/28/2025 3:07 PM	File folder	
DriverNotSigned	5/28/2025 3:07 PM	File folder	
STM32Bootloader.bat	2/10/2025 11:32 AM	Windows Batch File	

Figure 88. IQ2 Driver Software Folder Example

To complete the installation, double-click on the “STM32Bootloader.bat” file to install the current device driver. The current device driver will appear differently in the Device Manager when connected to an IQ2 in firmware download mode:

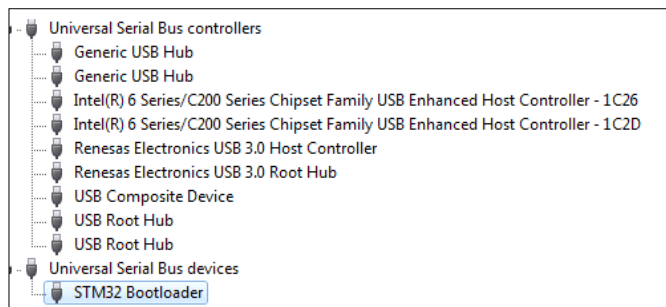

Figure 89. USB Controller Window Current Device Driver Example

If an IQ2 is connected while the driver is being updated, the IQ2 may need to be power-cycled and placed back into firmware download mode so that the new driver can be used.

Parts List

Table 12 lists kits available for the IQ2

Table-12. Kit Parts

Part No.	Title	Description
0411066-001	Kit – Adapter and Terminator	This is a complete kit for creating a network containing a TLS-450 Plus and up to 31 IQ2's. The adapter is a short 24cm (9.45") cable with an RJ-45 connector on one end for connecting to a TLS-450 Plus and an RJ-45 receptacle on the other end for using standard Ethernet cabling to connect to one or more IQ2's. The terminator is a small RJ-45 plug that is connected to the open RJ-45 receptacle on the IQ2 that is at the end of the network (see Figure 15).
0411067-001	Kit – Two Terminators	This kit contains two terminators, which are small RJ-45 plugs, for connection to the open RJ-45 receptacle on the IQ2 that is at the end of the network (see Figure 15). Only one terminator is required per network.
0411068-001	Kit – Replacement Contactor	This kit contains a replacement contactor (M1) for the IQ2. The contactor is a wear item and can be replaced if necessary. A contactor that needs to be replaced may be very noisy or make a loud buzzing sound or may fail to operate entirely.
0411069-001	Kit – Replacement Fuses	The IQ2 contains two 5 x 20 mm control power fuses rated at 2 A and 600 VAC. This kit provides replacement fuses should they be needed.
0411070-001	Kit – Replacement Display Assembly	This kit can be used to replace the entire front panel display that is mounted on the IQ2 door and connected to the IQ2 panel via a ribbon cable.

Appendix A: IQ2 Supported Pump Models

IQ2 Controllers with firmware greater than 1.x, where x can be any number, will support the pumps listed in Table A-1.

Table A-1. IQ2 Supported Pump Models

A	B	C	D	E	F
Pump Model Connected to IQ2	Pump Model to Select in Setup ¹	HP	Phase	Volts	Frequency
Red Jacket Motors Current Products					
UMP75U1, AGUMP75S1	UMP75U1	3/4	1	208/230VAC	60HZ
UMP75U3-3, AGUMP75S3-3	UMP75U3	3/4	1	220/230VAC	50HZ
UMP150U1, AGUMP150S1	UMP150U1	1.5	1	208/230VAC	60HZ
UMP150U3-3, AGUMP150S3-3	UMP150U3	1.5	1	220/230VAC	50HZ
UMP200U1-3, AGUMP200S1-3	UMP200U1	2	1	208/230VAC	60HZ
UMP200U3-4, AGUMP200S3-4	UMP200U3	2	1	220/230VAC	50HZ
UMP75U17-3, AGUMP75S17-3	UMP75U17	3/4	3	380/415VAC	50HZ
UMP150U17-3, AGUMP150S17-3	UMP150U17	1.5	3	380/415VAC	50HZ
UMP200U17-4, AGUMP200S17-4	UMP200U17	2	3	380/415VAC	50HZ
UMP500J4-2K	UMP500J4	5	3	208/230VAC	60HZ
UMP500J17-3K	UMP500J17	5	3	380/415VAC	50HZ
Red Jacket New 4 HP Products					
UMP400U4-3, AGUMP400S4-3	UMP400U4	4	3	208/230VAC	60HZ
UMP400U17-4, AGUMP400S17-4	UMP400U17	4	3	380/415VAC	50HZ
Franklin Electric Fueling Systems Top STPs					
STPM200, STPAGM200	FE STPM200,	2	1	208/230VAC	60HZ
STPM200B, STPAGM200B	FE STPM200B	2	1	200/250VAC	50HZ
STPM200C, STPAGM200C	FE STPM200C	2	3	380/415VAC	50HZ
STP150, STPAG150	FE STP150	1.5	1	208/230VAC	60HZ
STP150B, STPAG150B	FE STP150B	1.5	1	200/250VAC	50HZ
STP150C, STPAG150C	FE STP150C	1.5	3	380/415VAC	50HZ

¹For a pump model that appears in column A, which may contain multiple pump models, select the model on the IQ2 setup that appears in column B.

