

# Red Jacket IQ2 Controller

**Kit – Replacement Fuses (Part No. 0411069-001)**

## Installation Instructions

### Required Tools

- Torx T15 driver
- #2 Phillips screwdriver
- 5/16" Straight-slot screwdriver or 5/16" hex socket

### Instructions



**WARNING: EQUIPMENT HAS MULTIPLE POWER SOURCES.**

1. Disconnect all power from TB1 before performing any service. This includes incoming pump and IQ2 control power on L1-L2 (for single-phase pump applications) or L1-L3 (for 3-phase pump applications) as well as the D1 – D2 dispenser interface.
2. Remove and save the two shoulder screws securing the door in the closed position using a Torx T15 driver (see Figure 1).

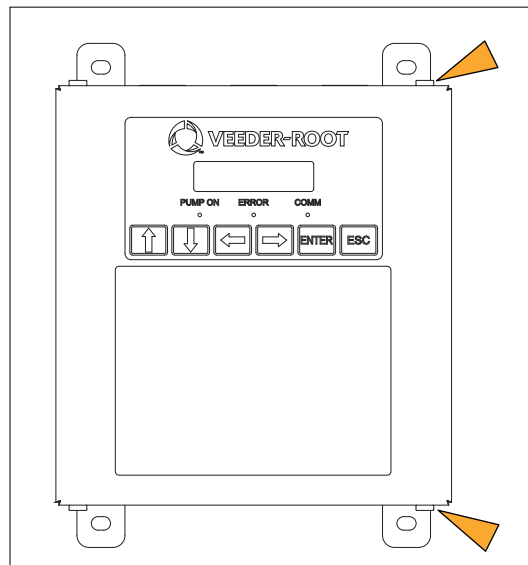

**Figure 1. IQ2 Enclosure Door Shoulder Screw Locations**

3. Swing open the enclosure door fully to the left.

- Remove all field wiring, installed to the bottom of TB1 and TB2 as well as field ground wires, using the #2 Phillips screwdriver and a 5/16" Straight-slot screwdriver OR 5/16" hex socket and recording their locations for later re-installation (see Figure 2).

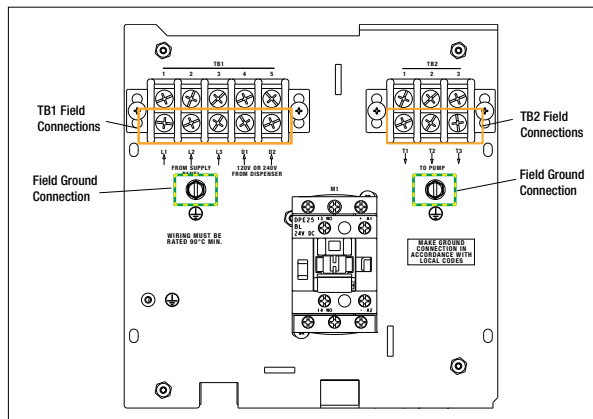

**Figure 2. Removing TB1 and TB2 Input Wiring**

- Carefully cut both zip-ties securing the display ribbon cable to the top of the enclosure, noting the size of the loop made by the zip-tie as you will replace them later (see Figure 3).

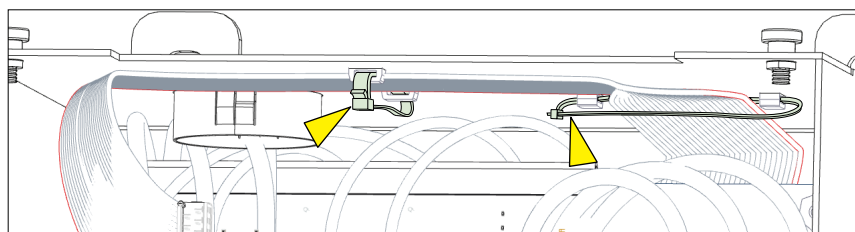

**Figure 3. Remove Two Display Ribbon Cable Zip-Ties**

- Remove and save the grounding bond screw and the six retaining screws from the mounting plate using a Torx T15 driver (see Figure 4).

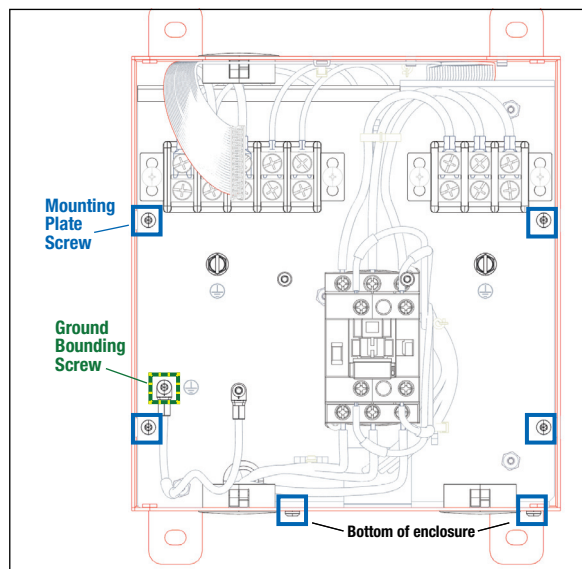

**Figure 4. Preparing to Remove Mounting Plate**

7. Carefully lift the mounting plate out of the enclosure and turn it over to access the fuses on the circuit board attached to the back side of the mounting plate. Take care not to damage the ribbon cable while you are handling the mounting plate. You may need to remove the conduit fittings from the bottom of the enclosure as well to lift out the mounting plate.
8. Replace the F1/F2 fuses with the two 2A, 600 Vac, 5x20mm fuses found in the kit (see Figure 5).

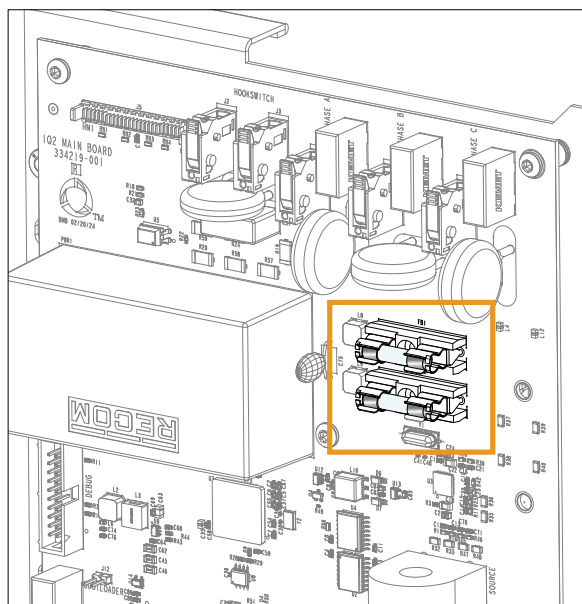

**Figure 5. Replace F1 and F2 Fuses**

9. Replace the mounting plate back into its original orientation and location within the enclosure.
10. Install the six mounting plate retaining screws from Step 6 above, starting with the two screws through the bottom of the enclosure, using a Torx T15 driver and torque to approximately 8.5 lbf-in (1 N•m).
11. Install the bonding ground wire and screw from Step 6 above using a Torx T15 driver torque to approximately 8.5 lbf-in (1 N•m).
12. Install two zip-ties found in the kit to replace the zip-ties that were cut in Step 5. Tighten the zip-ties just enough to restrain the movement of the ribbon cable, matching the factory set tightness of the two you cut earlier.
13. Replace conduit fittings if necessary.
14. Replace all field wiring removed in Step 4 using the #2Phillips screwdriver and a 5/16" Straight-slot screwdriver OR 5/16" hex socket and a torque terminal screws to approximately 20 lbf-in (2.2 N•m).
15. Close the enclosure door.
16. Install the shoulder screws saved from Step 2 with a Torx T15 driver and torque them to approximately 22.5 lbf-in (2.5 N•m).
17. Restore all power to TB1. This includes incoming pump and IQ2 control power on L1-L2 (for single-phase pump applications) or L1-L3 (for 3-phase pump applications) as well as the D1 – D2 dispenser interface.

Contact Veeder-Root / Red Jacket Technical Support for additional troubleshooting information at 1-800-323-1799 or [technicalsupport@veeder.com](mailto:technicalsupport@veeder.com)