

ORVR Nozzle

Installation and Maintenance Manual

**THIS MANUAL MUST BE GIVEN TO THE OPERATIONS MANAGER
AND KEPT ON THE PREMISES.**

WARNINGS AND INSTRUCTIONS

IMPORTANT SAFETY INFORMATION

This section introduces the hazards and safety precautions associated with installing, inspecting, maintaining or servicing this product. Before performing any task on this product, read this safety information and the applicable sections in this manual, where additional hazards and safety precautions for your task will be found. Fire, explosion, electrical shock or pressure release could occur and cause death or serious injury, if these safe service procedures are not followed.

PRELIMINARY PRECAUTIONS

You are working in a potentially dangerous environment of flammable fuels, vapors, and high voltage or pressures. Only trained or authorized individuals knowledgeable in the related procedures should install, inspect, maintain or service this equipment.

Read the Manual

Read, understand and follow this manual and any other labels or related materials supplied with this equipment. If you do not understand a procedure, call (800) 323-1719 to locate a qualified technician. It is imperative to your safety and the safety of others to understand the procedures before beginning work. **Make sure your employees and any service contractors read and follow the instructions.**

Follow the Regulations

Applicable information is available in National Fire Protection Association (NFPA) 30A; *Code for Motor Field Dispensing Facilities and Repair Garages*, NFPA 70; *National Electrical Code* (NEC), Occupational Safety and Hazard Association (OSHA) regulations and federal, state, and local codes. All these regulations must be followed. Failure to install, inspect, maintain or service this equipment in accordance with these codes, regulations and standards may lead to legal citations with penalties or affect the safe use and operation of the equipment.

Prevent Explosions and Fires

Fuels and their vapors will explode or burn, if ignited. Spilled or leaking fuels cause vapors. Even filling customer tanks will cause potentially dangerous vapors in the vicinity of the dispenser or island.

Working Alone

It is highly recommended that someone who is capable of rendering first aid be present during servicing. Familiarize yourself with Cardiopulmonary Resuscitation (CPR) methods, if you work with or around high voltages. This information is available from the American Red Cross. Always advise the station personnel about where you will be working, and caution them not to activate power while you are working on the equipment. Use the OSHA Lockout/Tagout procedures. If you are not familiar with this requirement, refer to OSHA documentation.

Working With Electricity Safely

Ensure that you use safe and established practices in working with electrical devices. Poorly wired devices may cause a fire, explosion or electrical shock. Ensure that grounding connections are properly made. Ensure that you do not pinch wires when replacing covers. Follow OSHA Lockout/Tagout requirements. Station employees and service contractors need to understand and comply with this program completely to ensure safety while the equipment is down. Before you start work, know the location of the Emergency Power Cutoff Switch (the E-STOP). This switch cuts off power to all fueling equipment and submerged turbine pumps and is to be used in the event of an emergency. The buttons on the console at the cashier's station WILL NOT shut off electrical power to the pump/dispenser. This means that even if you press a button on the console labeled EMERGENCY STOP, ALL STOP, PUMP STOP, or something similar, fuel may continue to flow uncontrolled.

Hazardous Materials

Some materials may present a health hazard if not handled correctly. Ensure that you clean hands after handling equipment. Do not place any equipment in the mouth.

WARNING! FAILURE TO COMPLY WITH THE FOLLOWING WARNINGS AND SAFETY PRECAUTIONS COULD RESULT IN PROPERTY DAMAGE, INJURY OR DEATH.

FIRE HAZARD! Do **NOT** use **power tools** (Class I Division I and Class I Division II) during the installation or maintenance of equipment. Sparking could ignite fuel or vapors, resulting in fire.

CHEMICAL EXPOSURE HAZARD! Wear appropriate **safety equipment** during installation or maintenance of equipment. Avoid exposure to fuel and vapors.

FUEL SPILL! Do **NOT** install unlisted ads/billboards, and do **NOT** install any other unlisted after-market device on any automatic nozzle. Doing so may change the sensitivity of the shut-off mechanism, which may cause the nozzle not to shut off, resulting in a fuel spill. Please see sensitivity test in Underwriters Laboratory Specification UL842.

REQUIREMENTS FOR USE

- The ORVR Nozzle is designed for use only at facilities dispensing motor fuels.
- Application of nozzles must be consistent with NFPA Code 30A, OSHA regulations, and federal, state and local fire codes, and other applicable local regulations.
- Injury or damage may result from splash-back or spillage if the nozzle is operated in excess of the applicable regulatory high-flow rates.
- The selection of any Veeder-Root product must be based upon physical specifications and limitations and the product's compatibility with the materials to be handled. Veeder-Root makes no warranty of fitness for a particular purpose. See Warranty below.
- All Veeder-Root products should be used in accordance with applicable federal, state and local laws, ordinances and regulations.

OPERATING PRECAUTIONS

Post the warning signs required by the current edition of NFPA 30-A, Section 9.2.5.4 in a conspicuous location. We recommend that you post the following warnings in a conspicuous location visible to those using the equipment. Contact authorities having local jurisdiction for additional required warnings.



- **TURN OFF** your engine before refueling, and **DO NOT RESTART** your engine until fueling is completed.
- **DISCHARGE YOUR STATIC ELECTRICITY** before fueling by touching with your bare hand grounded metal on your car or on dispenser away from nozzle
 - Failure to discharge static electricity could cause a spark which could ignite fuel vapors.
 - **DO NOT** reenter your vehicle during fueling, because this could recharge your body with static electricity. If you must re-enter your vehicle, be sure to discharge your static electricity again before you touch the nozzle.
- **NO SMOKING.** Extinguish all open flames and pilot lights, such as on RV appliances.
- **TURN OFF** cell phones and other electronic devices to avoid distractions while fueling.
- **DO NOT** leave nozzle unattended. Nozzle performance and the automatic shut-off are influenced by many factors. **STOP THE PUMP IMMEDIATELY** if the nozzle does not shut off after refueling.
- **WARNING! DO NOT REMOVE NOZZLE FROM FUEL PIPE IF FIRE STARTS.** Move back from dispenser and inform the attendant. Use the emergency shut-off button to stop the pump if the attendant is not available at the site.
- **DO NOT ALLOW CHILDREN** to pump gasoline. The equipment should be used only by persons of legal driving age.
- **GASOLINE CAN BE HARMFUL OR FATAL IF SWALLOWED.** Long-term exposure may cause cancer. Keep eyes and skin away from liquid gasoline and gasoline vapors. Avoid prolonged breathing of gasoline vapors
- **USE ONLY APPROVED PORTABLE CONTAINERS.** Dispense gasoline into approved portable containers placed on the ground. **NEVER FILL PORTABLE CONTAINERS IN OR ON THE VEHICLE.** If you do, static electricity generated in dispensing fuel can create a spark that ignites fuel vapors causing a fire.
 - **WHILE FILLING AN APPROVED PORTABLE CONTAINER,** manually hold the trigger on the nozzle for a low flow rate, and **DO NOT** engage the nozzle's hold-open clip in high position.
 - **KEEP THE NOZZLE TOUCHING THE PORTABLE CONTAINER WHEN FILLING THE PORTABLE CONTAINER** to discharge any static electricity generated in filling the container. If you do not do so, static electricity generated in dispensing fuel can create a spark that ignites fuel vapors causing a fire.

Notice

Veeder-Root makes no warranty of any kind with regard to this publication, including, but not limited to, the implied warranties of merchantability and fitness for a particular purpose.

Veeder-Root shall not be liable for errors contained herein or for incidental or consequential damages in connection with the furnishing, performance, or use of this publication.

Veeder-Root reserves the right to change system options or features, or the information contained in this publication.

This publication contains proprietary information which is protected by copyright. All rights reserved. No part of this publication may be photocopied, reproduced, or translated to another language without the prior written consent of Veeder-Root.

DAMAGE CLAIMS / LOST EQUIPMENT

Thoroughly examine all components and units as soon as they are received. If any cartons are damaged or missing, write a complete and detailed description of the damage or shortage on the face of the freight bill. The carrier's agent must verify the inspection and sign the description. Refuse only the damaged product, not the entire shipment.

VEEDER-ROOT'S PREFERRED CARRIER

1. Contact VR Customer Service at 800-873-3313 with the specific part numbers and quantities that were missing or received damaged.
2. Fax signed Bill of Lading (BOL) to VR Customer Service at 800-234-5350.
3. VR will file the claim with the carrier and replace the damaged/missing product at no charge to the customer. Customer Service will work with production facility to have the replacement product shipped as soon as possible.

CUSTOMER'S PREFERRED CARRIER

1. It is the customer's responsibility to file a claim with their carrier.
2. Customer may submit a replacement purchase order. Customer is responsible for all charges and freight associated with replacement order. Customer Service will work with production facility to have the replacement product shipped as soon as possible.
3. If "lost" equipment is delivered at a later date and is not needed, VR will allow a Return to Stock without a restocking fee.
4. VR will NOT be responsible for any compensation when a customer chooses their own carrier.

RETURN SHIPPING

For the parts return procedure, please follow the appropriate instructions in the "General Returned Goods Policy" and "Parts Return" pages in the "Policies and Literature" section of the Veeder-Root **North American Environmental Products** price list.

WARRANTY

Please see page v.

Warranty

For Veeder-Root ORVR compliance hanging hardware components, the following warranty applies:

We warrant that this product shall be free from defects in material and workmanship for a period of fifteen (15) months from the date of invoice thereof. We will repair or replace at our option the product if the product is returned to us transportation charges prepaid by user within the warranty period, and is determined by us to be defective. This warranty will not apply: (1) to any product which has been subject to misuse, abuse, negligence, accident, or drive-offs; (2) to systems that are misapplied or are not installed per Veeder-Root's specifications, or which have been modified, rebuilt or repaired by unauthorized persons; or (3) to damage resulting from acts of God. Repair or replacement of the defective part or component under the terms of this warranty is the **EXCLUSIVE REMEDY**. Veeder-Root is not liable for incidental, consequential, or indirect damages or loss, including, without limitation, personal injury, death, property damage, environmental damages, cost of labor, clean-up, downtime, installation and removal, product damages, loss of product, or loss of revenue or profits. **THE WARRANTY CONTAINED HEREIN IS EXCLUSIVE AND THERE ARE NO OTHER EXPRESS, IMPLIED, OR STATUTORY WARRANTIES. WARRANTIES OF MERCHANTABILITY OR FITNESS FOR A PARTICULAR PURPOSE ARE EXPRESSLY EXCLUDED.**

WARRANTY TAG

Warranty tag shipped with product (see example below) must be filled out and submitted with a return for processing to occur. For the complete parts return procedure, please follow the appropriate instructions in the "General Returned Goods Policy" and "Parts Return" pages in the "Policies and Literature" section of the Veeder-Root North American Environmental Products price list.

SITE INFORMATION INFORMACIÓN DEL SITIO	SERVICE INFORMATION INFORMACIÓN DEL SERVICIO
DATE: FECHA:	SERVICE CONTRACTOR: CONTRATISTA DEL SERVICIO:
STATION NAME: NOMBRE DE LA ESTACIÓN:	SERVICE TECH: TECH DEL SERVICIO:
STORE # ALMACÉN #	TECH CERTIFICATION # CERTIFICACIÓN DEL TECH #
CITY: STATE: CIUDAD: ESTADO:	DISTRIBUTOR: DISTRIBUIDOR:
(Must be troubleshoot / removed by V-R ORVR certified tech) (debe ser localizan averías / quitado por tech certificado)	
 VEEDER-ROOT ORVR HARDWARE WARRANTY TAG ETIQUETA DE GARANTIA ORVR	
<small>No warranty accepted without tag filled out and attached. Ninguna garantía será aceptada sin esta tarjeta adherida y completada.</small>	

Warranty Tag - Side 1

VR PART NO. _____	FIGA # _____
NÚMERO PARTE VR:	FIGA # (Orden de Retorno)
Serial # _____	Replacement Serial # _____
Número de Serie:	Reemplazada por:
WARRANTABLE DEFECTS (CHECK ONLY ONE) DEFECTO ENCONTRADO (Señale una solamente)	
<input type="radio"/> Will Not Shut Off No dispara automáticamente	<input type="radio"/> Air-to-Liquid Test Failed Falla en prueba de tasa
<input type="radio"/> Will Not Dispense No despacha	<input type="radio"/> Pressure Decay Test Failed Fuga de Vapor
<input type="radio"/> Shuts-Off During Use Dispara continuo en despacho	<input type="radio"/> Fuel Dispenses Without Pulling Lever Gasolina despacha sin soltar la palanca
<input type="radio"/> Fuel Leaks at: (Of Component) (Área)	<input type="radio"/> Other (Describe below) Otro (Describe debajo)
Comments: _____	Comentarios: _____

Warranty Tag - Side 2

IMPORTANT SAFETY INFORMATION ii
 PRELIMINARY PRECAUTIONS ii
 REQUIREMENTS FOR USE..... ii
 OPERATING PRECAUTIONS iii

Introduction

Certification 1
 Related Manuals 1
 Approved Stage-II System Applications 1
 Safety Precautions 2

Installation

Readying Dispenser for ORVR Nozzle Installation 4
 Nozzle Installation 6
 Disabling the “Puff Circuit” for the Vaporvac System 7
 Gilbarco Encore Dispenser Nozzle Hook Adjustment 8
 Step One: Preparation..... 8
 Step Two: Remove nozzle boot(s) from dispensing unit. 8
 Step Three: Remove nozzle hook from nozzle boot..... 9
 Step Four: Determine Nozzle Hook Position 9
 Step Five: Drill New Holes..... 9
 Step Six: Assemble nozzle hook to nozzle boot..... 9
 Step Seven: Test nozzle hook adjustment using new nozzle..... 9
 Step Eight: Install nozzle boot(s) onto dispensing unit. 9
 Step Nine: Re-insert Nozzles into the boot..... 9
 Nozzle Testing 10
 EQUIPMENT REQUIRED 10
 ELECTRICAL CONTINUITY TEST 10
 Leak Test..... 10
 FLOW TEST 10
 SHUT-OFF TEST 10
 A/L (Air-to-Liquid Ratio) Testing 11
 Checking A/L with Other Devices 12
 OTHER TESTS 13
 Recommended ORVR Nozzle Maintenance 14
 Daily Inspection 14
 Monthly Inspection..... 14
 Annual Testing..... 14
 Product Life 14
 In Case Of Emergency 14

Figures

Figure 1. Complete V-R ORVR Hanging Hardware Assembly 3
 Figure 2. Removing Hold-Open Clip 5
 Figure 3. Connecting ORVR Nozzle to Primary Hose Assembly 6
 Figure 4. Locating Puff Circuit Jump Jack 7
 Figure 5. Gilbarco Encore Hook Repositioning 8
 Figure 6. A/L Adapter/Roots Meter Test Setup 12
 Figure 7. Non-Roots A/L Adapter Test Setup 13

Introduction

This manual describes how to install the Veeder-Root ORVR nozzle to the Veeder-Root ORVR hanging hose assembly. Do not attempt to use this nozzle with other hanging hose assemblies.

The ORVR primary hose assembly contains a mechanical sensor which allows for proper vapor collection on traditional non-ORVR vehicles, but limits air ingestion when fueling ORVR vehicles.

The fuel section of the ORVR nozzle uses an automatic shutoff sensing port near the end of the spout. When the level of fuel reaches this sensing port, the nozzle automatically shuts off. A two position hold open latch is located beneath the lever to control the flow. The vapor collection section of the ORVR nozzle has a valve to prevent loss of vapor when the nozzle is not being used.

The no pressure/no flow device causes the ORVR nozzle to shut off whenever the dispenser shuts off fuel flow. This feature meets the NFPA Code 30A requirement regarding self-service nozzles with a hold-open latch.

The Veeder-Root ORVR Primary and Whip hoses are inverted coaxial vapor recovery hoses in which the outer hose delivers the fuel to the nozzle and the inner hose returns the vapors collected. The Veeder-Root nozzle and hose components use a special hose thread size (1-1/4 - 18) that is NOT compatible with the M34 thread size on standard inverted coaxial hoses.

This work should only be done by a knowledgeable and experienced individual. If further assistance for technical support is required, please visit www.veeder.com or call (800) 323-1719 to locate a qualified technician.

Certification

Veeder-Root requires that technicians satisfactorily complete the Veeder-Root ORVR certification course before performing installation, maintenance, servicing, testing or troubleshooting of Veeder-Root ORVR Hanging Hardware Systems.

Warranty claims may only be submitted by authorized V-R Distributors and Contractors.

Related Manuals

577013-887	ORVR Primary Hose, Breakaway and Whip Hose Installation and Maintenance Manual
577013-889	ORVR Hanging Hardware System Troubleshooting Manual



Approved Stage-II System Applications

The Veeder-Root ORVR compliance hanging hardware is approved by the Texas Commission on Environmental Quality (TCEQ) as a retrofit to the following stage-II systems:

- Gilbarco VaporVac system (CARB Executive Order G-70-150)
- Wayne WayneVac system (CARB Executive Order G-70-153)

Safety Precautions

The following safety symbols may be used throughout this manual to alert you to important safety hazards and precautions.

 <p>EXPLOSIVE Fuels and their vapors are extremely explosive if ignited.</p>	 <p>ELECTRICITY High voltage exists in, and is supplied to, the device. A potential shock hazard exists.</p>	 <p>TURN OFF CELL PHONE Turn off cell phone or other device until fueling is complete and nozzle is returned to cradle.</p>
 <p>TURN ELECTRICAL POWER OFF Live power to a device creates a potential shock hazard. Turn Off electrical power to the device and associated accessories when servicing the unit.</p>	 <p>WARNING Heed the adjacent instructions to avoid damage to equipment, property, environment or personal injury.</p>	 <p>DISCHARGE STATIC ELECTRICITY Failure to discharge static electricity before fueling may ignite gasoline vapors.</p>
 <p>FLAMMABLE Fuels and their vapors are extremely flammable.</p>	 <p>INJURY TO EYES AND SKIN Careless or improper handling of gasoline can result in bodily injury. If in eyes, irrigate with water for at least 15 minutes. On skin wash area thoroughly with clear water. Seek medical advice immediately.</p>	 <p>FILL CONTAINERS ON GROUND DO NOT fill containers in or on the vehicle. Put approved container on ground to fill.</p>
 <p>CLEAN WORK AREA Dispose of fuel soaked materials properly and not into trash barrels that may be used by customers.</p>	 <p>READ ALL RELATED MANUALS Knowledge of all related procedures before you begin work is important. Read and understand all manuals thoroughly. If you do not understand a procedure, ask someone who does.</p>	 <p>DO NOT REENTER VEHICLE WHILE FUELING If you reentered your vehicle while fueling, touch grounded metal on dispenser before touching nozzle.</p>
 <p>APPROVED CONTAINERS Use nonbreakable, clearly marked containers, suitable for collecting and transporting hazardous fuels during service.</p>	 <p>USE SAFETY BARRICADES Unauthorized people or vehicles in the work area are dangerous. Always use safety cones or barricades, safety tape, and your vehicle to block the work area.</p>	 <p>UNATTENDED VEHICLE Do not leave nozzle unattended while dispensing fuel.</p>
 <p>NO POWER TOOLS Sparks from power tools (such as drills) can ignite fuels and their vapors.</p>	 <p>NO VEHICLES Moving vehicles in the area during service can create a potential for personal injury to you or others. Sparks from starting vehicles can ignite fuels and their vapors.</p>	 <p>DO NOT ALLOW CHILDREN TO DISPENSE FUEL Keep kids away from fueling area. Only licensed operators should refuel vehicles.</p>
 <p>LUBRICATE Lubricate o-rings using mineral oil or other suitable lubricant.</p>	 <p>DIRECTION OF FLOW An arrow on a component of the ORVR hose assembly indicates direction of flow through the device. Install component with arrow pointing in direction of nozzle.</p>	 <p>AVOID BREATHING GASOLINE VAPORS Gasoline inhaled may cause unconsciousness and burns to lips, mouth and lungs. Keep airway open. Seek medical advice immediately.</p>
 <p>NO SMOKING Sparks and embers from burning cigarettes or pipes can ignite fuels and their vapors.</p>	 <p>NO OPEN FLAMES Open flames from matches, lighters, welding torches, etc. can ignite fuels and their vapors.</p>	 <p>DO NOT SWALLOW GASOLINE Gasoline ingested may cause unconsciousness and burns to internal organs. Do not induce vomiting. Keep airway open. Oxygen may be needed at scene. Seek medical advice immediately.</p>

Installation

Figure 1 illustrates the complete Veeder-Root ORVR hanging hardware assembly:

1. Vacuum Assist Whip Hose
2. Vacuum Assist Safety Breakaway
3. Primary Hose Assembly with ORVR Sensor (nozzle end)
4. ORVR Nozzle

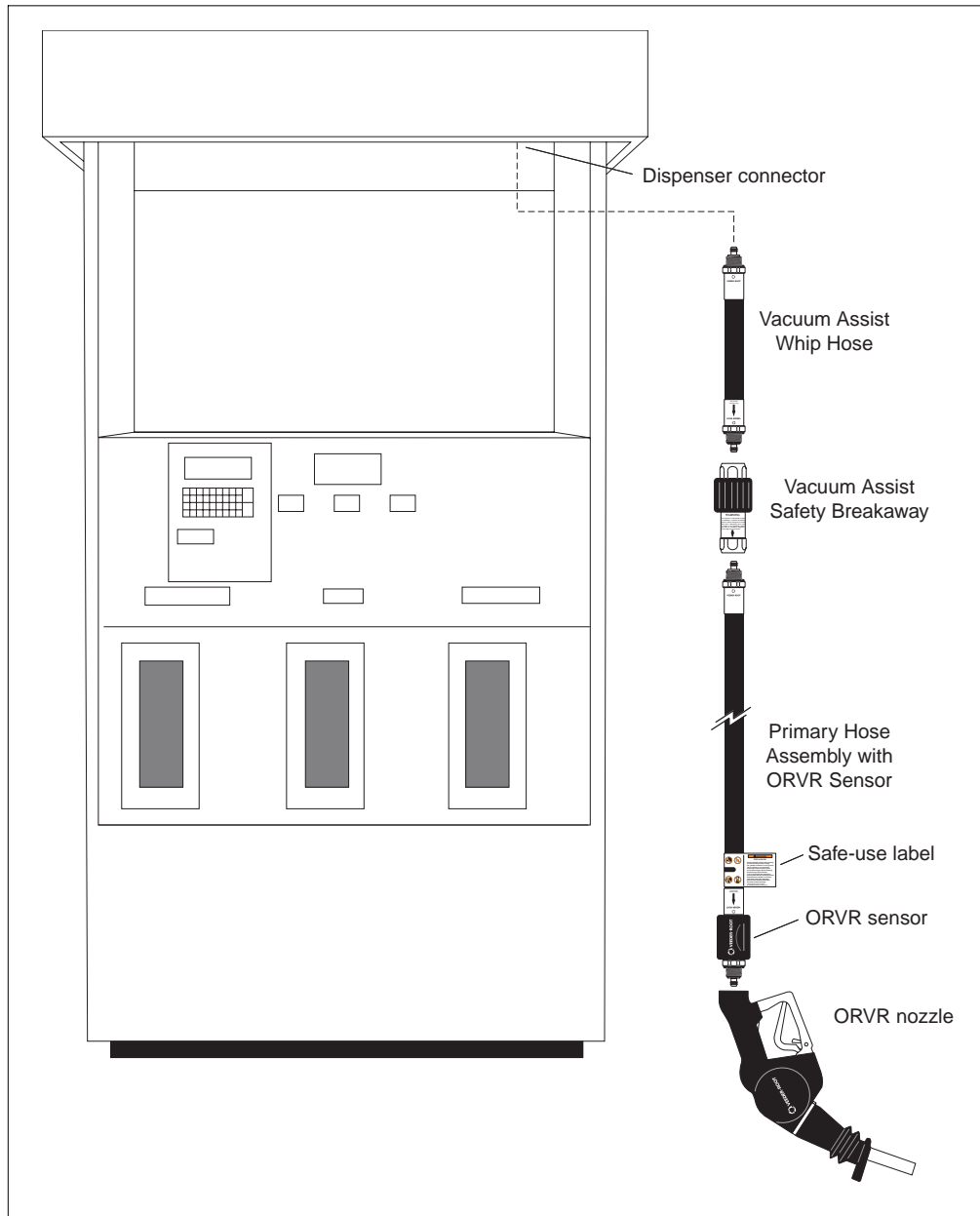

Figure 1. Complete V-R ORVR Hanging Hardware Assembly

Readying Dispenser for ORVR Nozzle Installation

Before installing the ORVR nozzle you must:

1. **Turn off electricity, tag and lockout the electrical power to the dispenser. Open the panel/cover to the base of the dispenser and close the dispenser's shear valves.**

Lockout/Tagout covers servicing and maintenance of machines and equipment in which the unexpected energization or start-up of the machine(s) or equipment or release of stored energy could cause injury to employees or personnel. Subpart S of 29 CFR Part 1910 – Electrical Hazards, 29 CFR Part 1910.333 contains specific Lockout/Tagout provision for electrical hazards.

WARNING! Electricity must be turned off to the dispenser and shear valves closed prior to service to avoid personal injury, damage to equipment, property, or the environment!

Total Electrical Shut-Off For Unit Where Nozzle To Be Installed

The first and most important information you must know is how to stop all fuel flow to the pump/dispenser. Locate the switch or circuit breakers that shut off all power to all fueling equipment and submerged turbine pumps (STPs) affecting the fuel dispenser on which you are installing nozzle.

⚠ WARNING	
	<p>The buttons on the console at the cashier's station WILL NOT shut off electrical power to the pump/dispenser. This means that even if you press a button on the console labeled EMERGENCY STOP, ALL STOP, PUMP STOP, or something similar, fuel may continue to flow uncontrolled.</p> <p>IN AN EMERGENCY, you must use the TOTAL ELECTRICAL SHUT-OFF for all of the fueling equipment, dispensing devices, and submerged turbine pumps (STPs) at the site, either by using the Emergency Power Cutoff Switch (the E-STOP) or the circuit breakers for all the fueling equipment, dispensing devices and submerged turbine pumps and not the console's buttons.</p>

Total Electrical Shut-Off Before Access

Installing a nozzle requires total electrical shut off of the fuel dispenser and the STP's affecting that dispenser. Understand the function and location of this switch or circuit breaker before inspecting, installing, maintaining, or servicing Veeder-Root equipment.

2. **Evacuating, Barricading and Shutting Off.** Any procedure that requires access to the pump/dispenser requires the following actions:



- An evacuation of all unauthorized persons and vehicles from the work area
 - Use of safety tape, cones or barricades at the affected unit(s)
 - A total electrical shut-off of the affected unit(s)
3. Open the panel/cover to the base of the dispenser and close the dispenser's shear valves.
 4. Before replacing or servicing dispensing components, such as the ORVR nozzle, hose, whip or breakaway, relieve the system pressure. (NFPA 30A 6.3.6) (2003 Revision)



5. If necessary, drain any product from the hose and nozzle being replaced into an approved container and remove the existing nozzle.
6. Dispenser modifications may be necessary for proper storage of the ORVR nozzle. Always comply with the dispenser instructions and local codes.



7. **If local regulatory codes prohibit use of the ORVR nozzle's hold-open clip it must be removed prior to nozzle installation. Remove the nozzle to a safe area. Place the nozzle on a flat surface. Locate the alloy rivet securing the hold-open clip and spring in the nozzle's handle (see Figure 2). Using a drill with a 3/16" (5mm) bit, drill out the rivet. Discard the clip, spring and any rivet shards.**

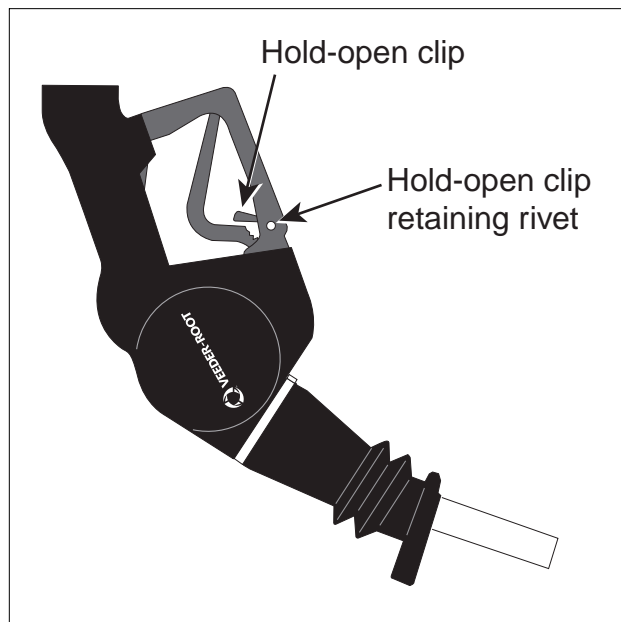

Figure 2. Removing Hold-Open Clip

Nozzle Installation



WARNING! If this is a new facility installation, the fueling point must be flushed into an approved container before installing the ORVR nozzle. Using the ORVR nozzle to flush the system could result in foreign material becoming lodged in the nozzle's valve and cause it to not shut off.



1. Before installing, inspect the threads of the Primary Hose fitting.
2. Inspect and lubricate the three o-rings on the Primary Hose fitting using mineral oil or other suitable lubricant (Figure 3). If O-rings are damaged or missing, use a Veeder Root O-ring Kit (P/N 900306-001).



WARNING! Do not use pipe dope or thread sealant.

3. Insert the hose fitting into the nozzle body, and tighten the hose to 50 foot-pounds (68Nm) - Refer to UL567. (See Figure 3)
4. Perform Flow test on the nozzle before putting it in service. Check for continuity of flow. For testing instructions refer to "Nozzle Testing".
5. All connections in the ORVR hanging hardware must be checked for leaks. Make repairs as required.

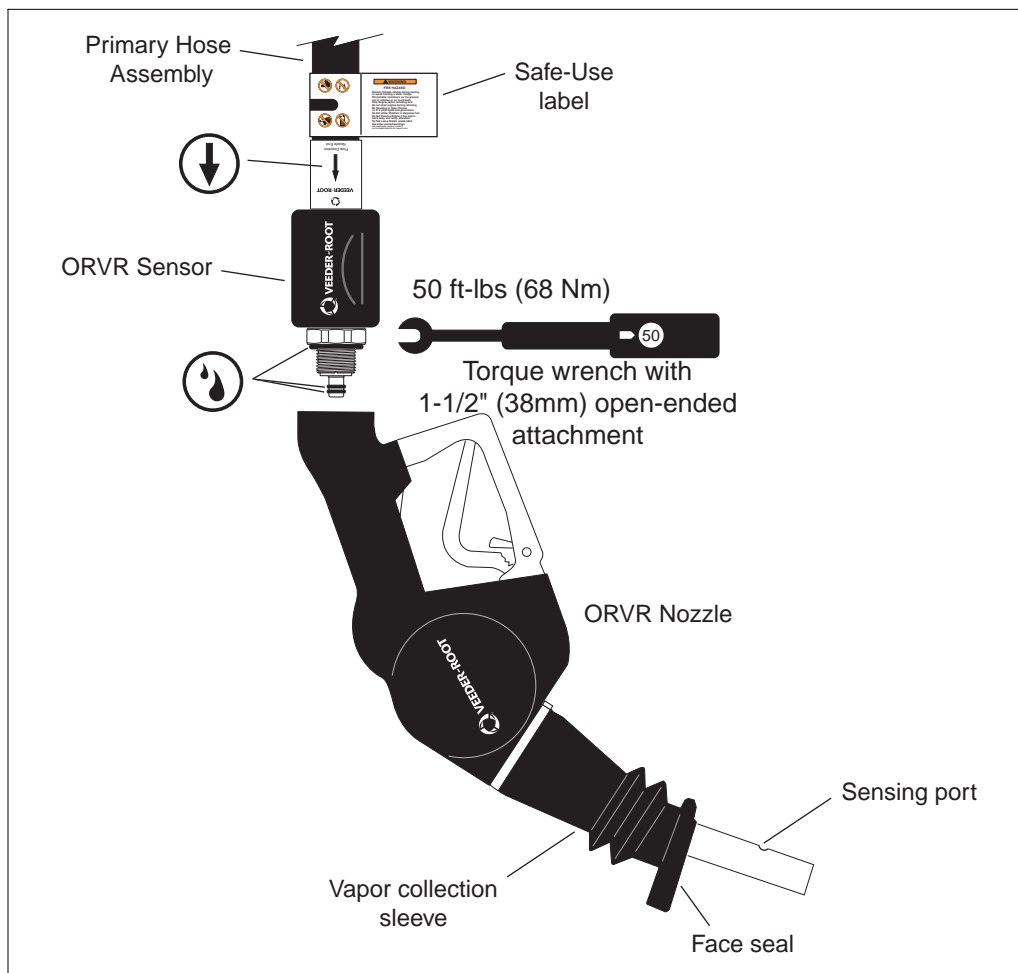

Figure 3. Connecting ORVR Nozzle to Primary Hose Assembly

Disabling the "Puff Circuit" for the VaporVac System

The following procedure only applies to the Gilbarco VaporVac system, there are no controller board modifications required for the WayneVac system.

The Gilbarco VaporVac system uses a puff or boost circuit that temporarily increases the speed of the vapor pump/motor during the beginning of a vehicle fueling transaction. The puff circuit must be disabled when using the Veeder-Root ORVR hanging hardware. If the puff circuit is not disabled, the ORVR valve could block the vapor path while fueling standard (non-ORVR) vehicles. The following steps describe how to disable the puff circuit.

1. Make sure the nozzle hooks or nozzle flap are in the "off" position and all power to the dispenser is disabled.
2. Open the electronic cabinet door and locate the VaporVac control electronics. The VaporVac control electronics are in the upper left corner of the electronic cabinet on Encore series dispensers. The VaporVac control electronics are in the upper card cage in the center of the electronic cabinet on Advantage series with factory installed VaporVac. The VaporVac control electronics are in the upper housing/canopy on Advantage and MPD series dispensers with VaporVac retrofit kits.
3. Locate the T19401-G2 or T18021-G1 VaporVac controller printed circuit board assembly. The VaporVac controller PCA has six red LED's and two blue potentiometers on the very front of the board that can be used as a good visual indicator (see Figure 4).
4. Next, locate the jump jack behind connector P1102 (see Figure 4). You will also see "CAL" and "OP" on each end of the jump jack positions.
5. Remove the jump jacks from positions JP1 and JP2. Removing these two jump jacks will disable the puff circuit.

Close and properly secure the electronic cabinet door. Restore power to the dispenser.

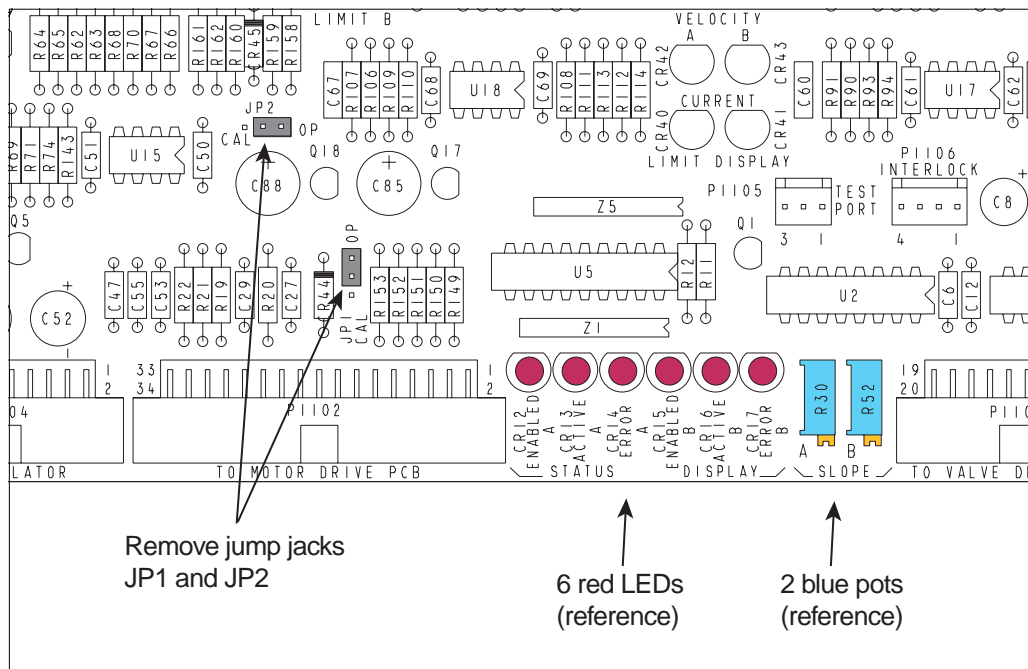

Figure 4. Locating Puff Circuit Jump Jack

Gilbarco Encore Dispenser Nozzle Hook Adjustment

This section is only for V-R ORVR nozzle installations in Gilbarco Encore dispensing units.

Required tools: drill, 7/32" or # 22 drill bit, 1/4" square-tip driver, 7 mm metric hex nut driver or socket, 3/8" nut driver or socket.



WARNING! AC or battery powered drills must not be used at the dispensing unit because of the danger of explosion or fire due to the presence of hazardous vapors.

STEP ONE: PREPARATION

1. Notify site personnel of work to be performed.
2. Secure work area.
3. Isolate dispensing unit from point-of-sale or pump controller.
4. Close shear valves.
5. Remove nozzle(s) from nozzle boot(s) and place on ground.

STEP TWO: REMOVE NOZZLE BOOT(S) FROM DISPENSING UNIT.

1. Loosen two nozzle boot mounting screws. (See Figure 5) using 1/4" square tip driver. Note: Save nozzle boot mounting screws for use later.
2. Remove nozzle boot from door by pulling toward you.

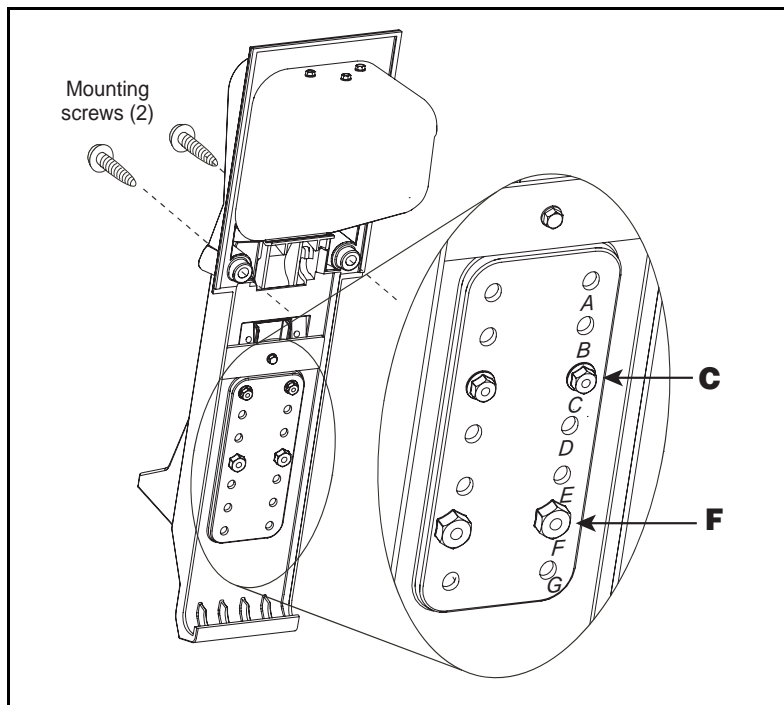

Figure 5. Gilbarco Encore Hook Repositioning

STEP THREE: REMOVE NOZZLE HOOK FROM NOZZLE BOOT.

1. Place nozzle boot face down on work surface covered with soft cloth to protect nozzle boot face.
2. See Figure 5 to identify existing nozzle hook retaining screw and nut locations. Identifying marks are located under right hand row of indented hole locations. Standard nozzle hook locations are positions A & D.
3. Use 7mm nut driver or socket to remove two upper hex head screws.
4. Use 3/8" nut driver or socket to remove two nuts from lower carriage bolts.
5. Remove nozzle hook and carriage bolts from nozzle boot. Save hex head screws, carriage bolts and nuts for use later.

STEP FOUR: DETERMINE NOZZLE HOOK POSITION

1. The hook should be lowered two (2) positions until the upper screws are in position "C" and the lower bolts are in position "F". See Figure 5 to identify nozzle hook retaining screws and nuts locations. Identifying marks are located under right hand row of indented hole locations.

STEP FIVE: DRILL NEW HOLES

1. Remove nozzle boot to a safe non-hazardous location and use 7/32" or # 22 drill bit to drill new holes as needed.
2. Once holes are drilled, remove nozzle hook and clean up debris around hole set.

STEP SIX: ASSEMBLE NOZZLE HOOK TO NOZZLE BOOT.

1. Reverse Step Three to assemble nozzle hook to nozzle boot.

STEP SEVEN: TEST NOZZLE HOOK ADJUSTMENT USING NEW NOZZLE.

1. Hold nozzle boot upright and insert nozzle over nozzle hook and into boot. Wiggle boot to verify the nozzle does not slip out of position.

STEP EIGHT: INSTALL NOZZLE BOOT(S) ONTO DISPENSING UNIT.

1. Reverse Step Two and install the adjusted nozzle boot onto the dispensing unit.

STEP NINE: RE-INSERT NOZZLES INTO THE BOOT.

Nozzle Testing

EQUIPMENT REQUIRED

Stop watch; approved 5-gallon grounded, vented, metal test container, MegOhmMeter, A/L test adapter (P/N 900304-001), and a vapor flow meter.

ELECTRICAL CONTINUITY TEST

The ORVR hanging hardware system (e.g. nozzle, hoses, and breakaway fittings) must be conductive in order to dissipate any static charge that is generated while fuel is being dispensed. The conductivity of ORVR hose assembly is obtained by either a metal-to-metal contact path from inlet to outlet or by the use of non-metallic electrically conductive materials (E.g. the rubber formulated for use in fuel hoses). Since conductivity is important to public safety, these components are tested to a maximum resistance by certifying bodies. Refer to PEI RP 400 for proper test equipment and method of testing.

LEAK TEST

1. The dispenser must be turned on and authorized to be able to open the ORVR nozzle and engage its hold-open clip.



WARNING! Static electric spark could ignite fuel causing a fire. Place container on ground prior to and during test. Nozzle must be in contact with container until the testing is complete to discharge any static electricity generated during the test.



2. Pump between one-half and one gallon of fuel into an approved container to purge the air out of the system, and then inspect each hose joint for liquid leaks.

FLOW TEST

1. The dispenser must be turned on and authorized to be able to operate the nozzle and engage the hold-open clip.



WARNING! Static electric spark could ignite fuel causing a fire. Place container on ground prior to and during test. Nozzle must be in contact with container until the testing is complete to discharge any static electricity generated during the test.



2. Start stop watch and flow into an approved test container with the nozzle lever held in the full open position for maximum flow rate and low clip position for minimum flow rate.
3. The minimum flow rate is 3 gpm (11.3 lpm) and the maximum flow rate is 10 gpm (37.8 lpm). The flow rate must not be below 3 gpm when the ORVR nozzle's hold-open clip is in its lowest position. The flow rate must not exceed 10 gpm when the nozzle is in the full open position. (U.S. Federal requirement.)
4. If the nozzle does not comply, recheck components of the ORVR assembly and repair prior to putting the fueling point into service.

SHUT-OFF TEST

1. The dispenser must be turned on and authorized to be able to open the ORVR nozzle and engage its hold-open clip.



WARNING! Static electric spark could ignite fuel causing a fire. Place container on ground prior to and during test. Nozzle must be in contact with container until the testing is complete to discharge any static electricity generated during the test.



2. Hold the nozzle spout's tip at least 3-4 inches (75 - 100 mm) away from the bottom of an approved container to prevent back pressure in spout.
3. Start flow with the nozzle lever's hold-open clip engaged in the low position until the gasoline covers the sensing port of the nozzle (reference Figure 3).
4. Nozzle must shut off.

5. Start flow with the nozzle lever's hold-open clip engaged in the high clip position until the gasoline covers the sensing port of the nozzle.
6. Nozzle must shut off.
7. Start flow with the nozzle's lever held fully open until the gasoline covers the sensing port of the nozzle.
8. Nozzle must shut off.
9. Each nozzle to be tested a minimum of 5 times in each clip position.
10. If no shut off occurs, check to make sure flow rate is greater than 3 gpm (11.3 lpm). Flow rate below 3 gpm will not allow the automatic shut-off feature to operate properly. If there is no shut-off above 3 gpm, replace nozzle.

A/L (Air-to-Liquid Ratio) Testing

A/L testing is recommended at the time of installation to avoid a fueling position or site from experiencing a possible nuisance (premature) nozzle tripping problem. Some local regulations may require an A/L test within 60 days of startup.

The following procedure should be used to test the A/L ratio using a traditional roots style A/L test device. This test requires that you use a Veeder-Root A/L nozzle adapter (P/N 900304-001) which can be purchased through your local Veeder-Root distributor.

1. Vent the UST vapor system to atmosphere before starting the A/L Testing procedure.
2. Securely attach a CARB approved vapor flow meter (or similar device) to the hose-barb fitting on the A/L Test Adapter.
3. Slide the A/L Test Adapter over the nozzle spout so that the side with the hose-barb fitting is closest to the nozzle body and so that the adapter face mates firmly and seals against the face seal (see Figure 6).
4. Compress the vapor collection sleeve bellows with the A/L Test Adapter and tighten the knob on the A/L Test Adapter so that it is securely attached to the spout.
5. Initialize the Flow Meter to begin to measure the volume of vapor collected.
6. The dispenser must be turned on and authorized to be able to open the ORVR nozzle and dispense fuel.



WARNING! Static electric spark could ignite fuel causing a fire. Place container on ground prior to and during test. Nozzle must be in contact with container until the testing is complete to discharge any static electricity generated during the test.

7. Flow approximately 5 gallons (or amount as specified by CARB approved A/L test equipment) of fuel into an approved test container with the nozzle lever held in the full open position.
8. Record the A/L or calculate the A/L ratio by dividing the volume of vapor collected by the volume of fuel dispensed.
 - For VaporVac systems:
 - If while the UST vapor system is vented, and the A/L is between 0.9 to 1.0, then no further adjustments are necessary (If the vapor space is not vented, A/L ratios between 0.9 to 1.1 are acceptable).
 - If while the UST vapor system is vented the A/L ratio is outside of the 0.9 to 1.0 range, then follow the vacuum system manufacturer's instructions for adjusting the vapor flow rates. Retest and verify that adjustments now bring the A/L ratio into compliance.
 - For WayneVac systems:
 - If the A/L is between 0.9 to 1.1, no further adjustments are necessary
 - If the A/L ratio is outside of the 0.9 to 1.1 range, then follow the vacuum system manufacturer's instructions for correcting the vapor flow rates.

9. Reseal the UST vapor system after the A/L ratios are set for all fueling points.



NOTE: A/L ratio's for the Veeder-Root ORVR system on VaporVac systems must intentionally be set to the lower half of the CARB approved A/L range due to the "A/L boost" that is created by the increased vacuum generated in the UST by the ORVR Sensor.

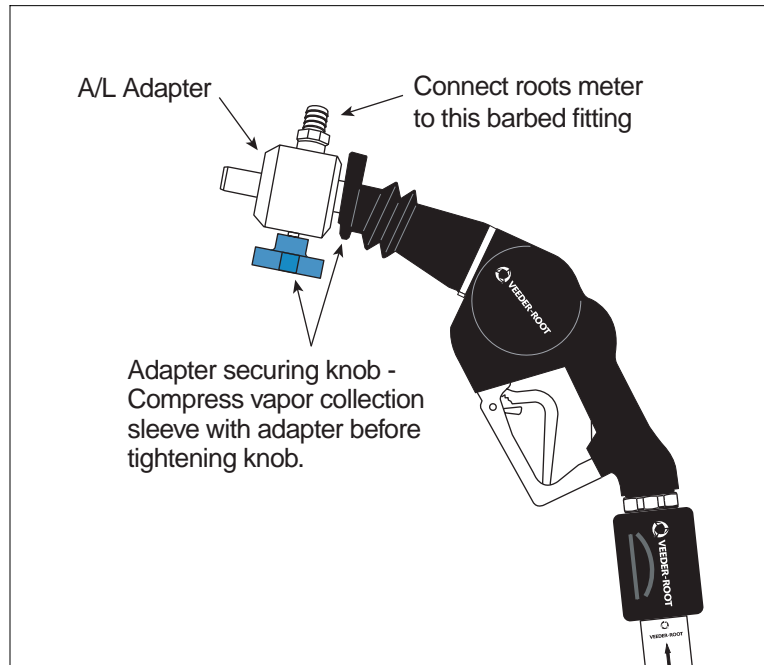

Figure 6. A/L Adapter/Roots Meter Test Setup

Checking A/L with Other Devices

Other A/L test devices may be used if approved by state and local agency regulations. Some A/L test devices are designed for nozzles with a coaxial nozzle spout (where the vacuum pickup occurs through holes in the spout). The ORVR nozzle uses a solid spout, which may not be compatible with these units. You will need to perform the following steps to test the Veeder-Root ORVR nozzle with these types of units.

1. You will need to purchase/obtain an A/L nozzle adapter (P/N 900304-001) that comes with a special surrogate test spout from your Veeder-Root distributor.
2. Remove all fittings from the $\frac{3}{4}$ NPT threaded opening in the A/L nozzle adapter. This opening normally connects to the roots meter.
3. Install the surrogate test spout into the $\frac{3}{4}$ NPT threaded opening on the A/L nozzle adapter.
4. Install the A/L nozzle adapter with the surrogate test spout onto the spout of the ORVR nozzle. Make sure the back of the adapter is making good contact with the face seal and is compressing the convolutes in the vapor collection sleeve.
5. Install the Airflow Sensor or coaxial nozzle spout adapter unit onto the special surrogate test spout. The holes in the test spout should be in between the elastomeric seals on the Airflow Sensor or coaxial nozzle spout adapter (see Figure 7).
6. Follow the A/L test device instructions for testing a Gilbarco VaporVac or Wayne WayneVac system with a 1.00 nominal A/L (mini-booted nozzle).

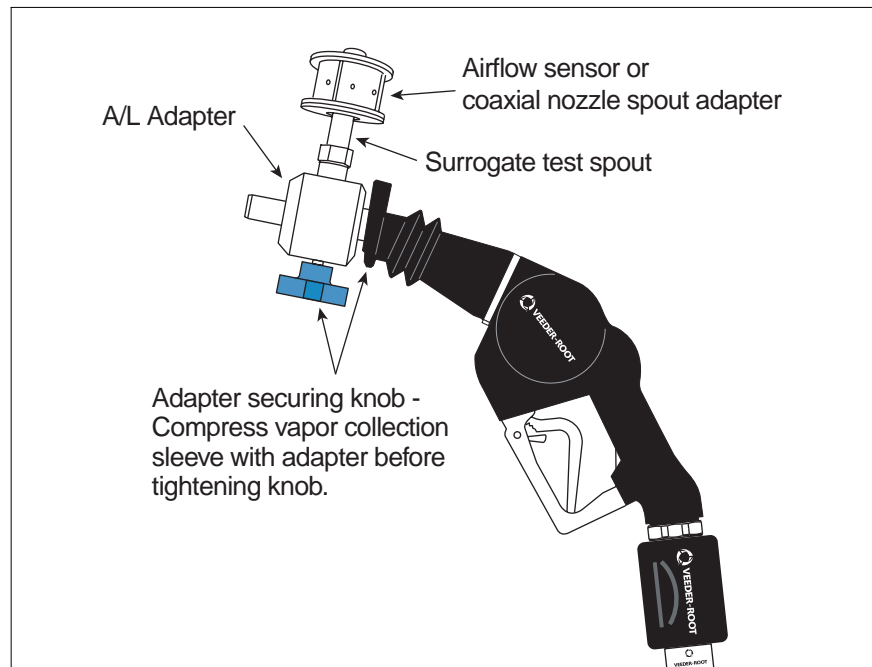

Figure 7. Non-Roots A/L Adapter Test Setup

OTHER TESTS

Conduct other nozzle tests as required by local authorities.

Recommended ORVR Nozzle Maintenance

DAILY INSPECTION

- Inspect that the swivel nut on the primary hose allows the nozzle to rotate smoothly and there are no fuel leaks. Verify that nozzle hold-open clip is present and operating correctly where use is allowed. Make sure the nozzle spout is not loose and not out of round. Replace nozzle if necessary.
- Inspect the rubber vapor collection sleeve and face seal for cuts, tears and excessive wear (see Figure 3 on page 6). Replace the nozzle if necessary.
- Inspect the safe-use label on the Primary Hose (Figure 3 on page 6). Replace the label if it is excessively worn or damaged or cannot be easily read.

MONTHLY INSPECTION

- Inspect nozzle spout for wear and deformation. Nozzle should be replaced immediately if spout is bent, the sensing port is blocked, or the end of the spout is rolled over. Failure to replace the nozzle may result in a hazardous spill, which can cause fire, damage to environment or severe bodily injury.
- Inspect nozzle for any leakages and replace as necessary.
- Ensure that there is a minimum flow rate of 3 gpm provided by the dispenser. For testing instructions, refer to “Nozzle Testing” on page 10.
- Inspect the operation and condition of the nozzle’s hold-open clip and spring (see Figure 2 on page 5). Replace the nozzle if necessary.
- Perform the shut-off test (“Nozzle Testing” on page 10).
- If required by local or state regulations or company policy, document all maintenance and inspection activity on the ORVR nozzle. This includes part replacements, drive-offs, etc.

ANNUAL TESTING

- Grasp the end of the spout assembly and attempt to wiggle or move the spout relative to the nozzle body. Tighten spout nut or replace nozzle as necessary.
- Lubricate the main valve stem where it extends through the nozzle body with a few drops of oil. This may be performed as regular maintenance as often as desired. Do not use grease.
- Perform the electrical continuity test (see “ELECTRICAL CONTINUITY TEST” on page 10).
- Perform A/L (Air-to-Liquid Ratio) Testing (see page 11).

Product Life

NOTE: Due to abuse, misuse, changing gasoline formulas, variation in maintenance practices, environmental conditions and/or conditions beyond the manufacturer’s control, dispensing equipment may need replacement before five (5) years. Inspections and proper maintenance procedures should be followed by the station manager to determine if replacement is required before five (5) years.

In Case Of Emergency

Following a drive-off or nozzle damage from customer abuse, lock the fueling point until a complete hanging hardware system inspection can be performed by a qualified technician. If assistance is required, please visit our website at www.veeder.com to locate a distributor or a service contractor.

Comply with any requirements of authorities having local jurisdiction.

