

Media-Isolated Mag Plus Probe Low Pressure-ISO Kit

Installation Guide

Notice

Veeder-Root makes no warranty of any kind with regard to this publication, including, but not limited to, the implied warranties of merchantability and fitness for a particular purpose.

Veeder-Root shall not be liable for errors contained herein or for incidental or consequential damages in connection with the furnishing, performance, or use of this publication.

Veeder-Root reserves the right to change system options or features, or the information contained in this publication.

This publication contains proprietary information which is protected by copyright. All rights reserved. No part of this publication may be photocopied, reproduced, or translated to another language without the prior written consent of Veeder-Root.

Contact TLS Systems Technical Support for additional troubleshooting information at 800-323-1799.

DAMAGE CLAIMS / LOST EQUIPMENT

Thoroughly examine all components and units as soon as they are received. If any cartons are damaged or missing, write a complete and detailed description of the damage or shortage on the face of the freight bill. The carrier's agent must verify the inspection and sign the description. Refuse only the damaged product, not the entire shipment.

Veeder-Root must be notified of any damages and/or shortages within 30 days of receipt of the shipment, as stated in our Terms and Conditions.

VEEDER-ROOT'S PREFERRED CARRIER

1. Contact Veeder-Root Customer Service at 800-873-3313 with the specific part numbers and quantities that were missing or received damaged.
2. Fax signed Bill of Lading (BOL) to Veeder-Root Customer Service at 800-234-5350.
3. Veeder-Root will file the claim with the carrier and replace the damaged/missing product at no charge to the customer. Customer Service will work with production facility to have the replacement product shipped as soon as possible.

CUSTOMER'S PREFERRED CARRIER

1. It is the customer's responsibility to file a claim with their carrier.
2. Customer may submit a replacement purchase order. Customer is responsible for all charges and freight associated with replacement order. Customer Service will work with production facility to have the replacement product shipped as soon as possible.
3. If "lost" equipment is delivered at a later date and is not needed, Veeder-Root will allow a Return to Stock without a restocking fee.
4. Veeder-Root will NOT be responsible for any compensation when a customer chooses their own carrier.

RETURN SHIPPING

For the parts return procedure, please follow the appropriate instructions in the "General Returned Goods Policy" pages in the "Policies and Literature" section of the Veeder-Root **North American Environmental Products** price list. Veeder-Root will not accept any return product without a Return Goods Authorization (RGA) number clearly printed on the outside of the package.

Introduction

| | |
|---|---|
| Related Manuals | 1 |
| Contractor Certification Requirements | 1 |
| Before You Begin | 1 |
| Safety Symbols | 2 |
| Low Pressure-ISO kit | 3 |

Installing the Mag Probe

| | |
|--|---|
| Before you begin | 4 |
| Attaching the float to the tube | 4 |
| Installing the Stainless Steel Tube into the Tank | 4 |
| Sealing the Stainless Steel Tube in the Tank Opening | 4 |
| Installing the Probe in the Stainless Steel Tube | 4 |
| Entering Custom Float Size | 6 |

Figures

| | | |
|-----------|--|---|
| Figure 1. | Mag Plus Probe Low Pressure-ISO Kit | 3 |
| Figure 2. | Media Isolated Mag Plus probe installation example | 5 |
| Figure 3. | Rain shield installed position | 6 |

Introduction

This manual contains installation instructions for installing the Veeder-Root Media Isolated Mag Plus probe Low Pressure-ISO kit.

Related Manuals

Depending on your installed console, you must reference the appropriate manual below, to connect the probe to the console.

| | |
|------------|---|
| 576013-879 | TLS-3XX Series Site Prep and Installation Manual |
| 577013-879 | TLS-4XX Console Site Prep and Installation Manual |
| 576013-623 | TLS-3XX Series System Setup Manual |
| 577013-757 | TLS2 Setup Manual |

Contractor Certification Requirements

Veeder-Root requires the following minimum training certifications for contractors who will install and setup the equipment discussed in this manual:

Installer Certification: Contractors holding valid Installer Certification are approved to perform wiring and conduit routing, equipment mounting, probe and sensor installation, tank and line preparation, and line leak detector installation.

TLS-350 Technician Certification: Contractors holding valid TLS-350 Technician Certifications are approved to perform installation checkout, startup, programming and operations training, troubleshooting and servicing for all Veeder-Root TLS-300 or TLS-350 Series Tank Monitoring Systems, including Line Leak Detection and associated accessories.

TLS-450 Technician Certification: Contractors holding valid TLS-450 Technician Certifications are approved to perform installation checkout, startup, programming and operations training, troubleshooting and servicing for all Veeder-Root TLS-450 Series Tank Monitoring Systems, including Line Leak Detection and associated accessories.

In-Station Diagnostics (ISD-PMC) Technician Certification: ISD PMC Contractors holding a valid ISD/PMC Certification are approved to perform (ISD/PMC) installation checkout, startup, programming, and operations training. This training also includes troubleshooting and service techniques for the Veeder-Root In-Station Diagnostics system. A current Veeder-Root Technician Certification is a prerequisite for the ISD/PMC course. After successful completion of this course the contractor will receive a certificate as well as a Veeder-Root ISD/PMC including Carbon Canister Vapor Polisher contractor certification card. This Certification includes Executive Orders 202, 203, 204 and the Veeder-Root Vapor Polisher.

Warranty Registrations may only be submitted by selected Distributors.

Before You Begin

Before you begin installation, read the following guidelines:





- It is essential that you carefully read and follow the warnings and instructions in this manual to protect yourself and others from serious injury, explosion, or electrical shock.
- For safety reasons, we have taken particular care in the design of this product to limit the power in the wiring to the product tanks and to keep that wiring physically separated from any other wiring. It is your responsibility to

maintain the effectiveness of these safety features by installing this product in accordance with the instructions and warnings which follow. Your failure to do so could create danger to life and property.

- Failure to install this probe kit in accordance with its instructions and warnings will result in voiding of all warranties connected with this product. This unit does not contain any user controls. Opening or tampering with a magnetostrictive probe will result in voiding the warranty.



Safety Symbols

The following safety symbols may be used throughout this manual to alert you to important safety hazards and precautions

| | |
|--|--|
|  <p>EXPLOSIVE Fuels and their vapors are extremely explosive if ignited.</p> |  <p>FLAMMABLE Fuels and their vapors are extremely flammable.</p> |
|  <p>READ ALL RELATED MANUALS Knowledge of all related procedures before you begin work is important. Read and understand all manuals thoroughly. If you do not understand a procedure, ask someone who does.</p> |  <p>WARNING Heed the adjacent instructions to avoid damage to equipment, property, environment or personal injury.</p> |



WARNING

| | |
|---|---|
|    | <p>Fire or explosion resulting in serious injury or death could result if the equipment is improperly installed or modified.</p> <ol style="list-style-type: none"> 1. It is essential that you carefully read and follow the warnings and instructions in this manual to protect yourself and others from serious injury due to fire or explosion. Failure to do so could result in undetected potential environmental and health hazards. 2. Comply with all federal, state, and local codes, and other applicable safety codes. All wiring must comply with UL/CUL standards and other local electrical and pressure vessel codes. 3. Failure to comply with these requirements could result in death, serious personal injury, property loss, or equipment damage. 4. Substitution of components may impair intrinsic safety. 5. Circuitry within the probe and console barrier form an intrinsically safe, energy limited system. The probe wiring is intrinsically safe only when connected to Veeder-Root consoles having form numbers 8466, 8469, 8470, 8482, 8485, 8560, or 8600. |
|---|---|

Low Pressure-ISO kit

This equipment is intended to be installed in a tank that has a threaded 1-1/2" NPT opening (331807-XXX kit) or 2" NPT opening (332707-XXX kit) to accept the probe and connectors. The threaded openings must meet local codes for pressure vessels.

- 331807-XXX ISO Installation Probe Kit, with a 1.5" (38.1 mm) Float, rated for low pressure with a working temperature range between -40°C and +60°C.
- 332707-XXX ISO Installation Probe Kit, with a 2" (50.8 mm) Float, rated for low pressure with a working temperature range between -40°C and +60°C.

Table 1. Low Pressure-ISO Installation Kits

| Qty. | Part Description | 1-1/2" NPT Kit P/N 331807-XXX | 2" NPT Kit P/N 332707-XXX |
|------|--|----------------------------------|------------------------------|
| 1 | Tube group | 331800-XXX | 331800-XXX |
| 1 | Float | 331797-001 | 331797-002 |
| 1 | Male connector 7/8" to 1" NPT | 576008-643 | 576008-643 |
| 1 | Reduction bushing 1-1/2" NPT to 1" NPT | 576008-700 | ----- |
| 1 | Reduction bushing 2" NPT to 1" NPT | ----- | 576008-699 |
| 1 | Float retaining ring | 511805-378 | 511805-378 |
| 1 | Cable | 330272-XXX | 330272-XXX |
| 1 | Cable Seal Kit (cord grip fitting, sealant pack, wire nuts, and tie wraps) | 330020-067 | 330020-067 |
| 1 | Rain shield | 331880-001 | 331880-001 |

Where XXX is used to indicate various tube lengths between 2 feet (610 mm) and 12 feet (3658 mm).

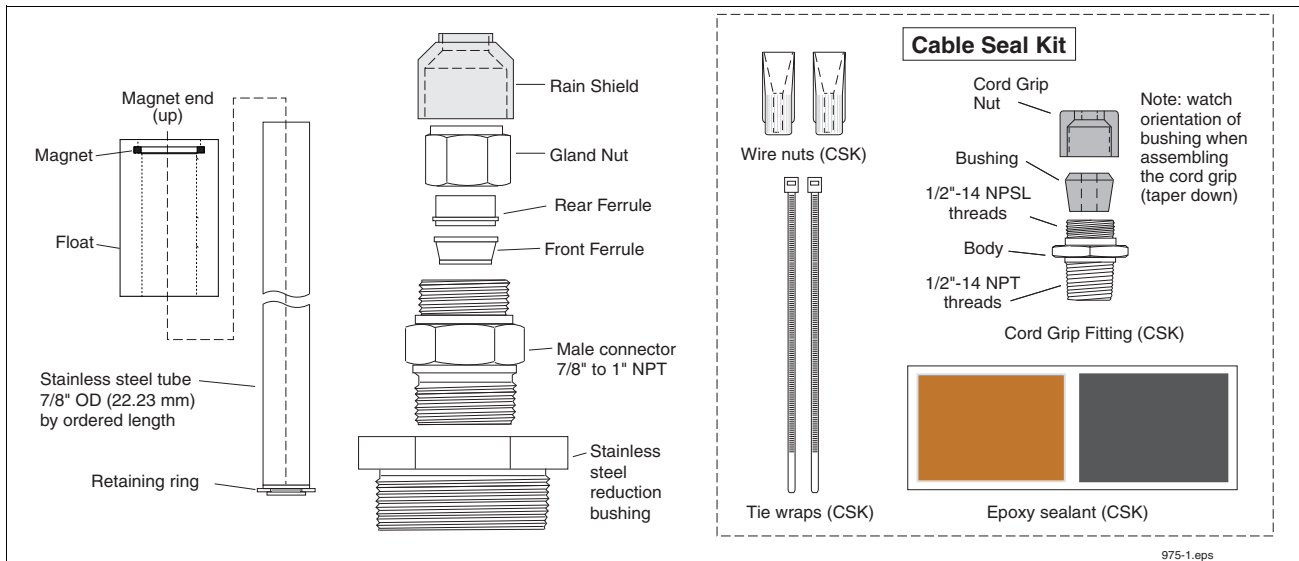

Figure 1. Mag Plus Probe Low Pressure-ISO Kit

Installing the Mag Probe

NOTE: To ensure that the probe/tube kit can be installed, the probe length should be at least 6 inches (152.4 mm) longer than the tank's inside diameter.

Before you begin



1. Make sure that the tank is depressurized (drained) and free of liquid and combustible vapors.
2. Remove any sludge from the bottom of the tank. Sludge can interfere with the proper operation of the float.

Attaching the float to the tube

Slide the large shipping washer off of the stainless steel tube and discard it. Carefully slide the stainless steel float, non-magnet end first, onto the tube and down against the retaining ring at the bottom of the tube (the float end marked "TOP" should be facing up). The float must be installed magnet-end up to measure fuel correctly (see Figure 1).

Installing the Stainless Steel Tube into the Tank

1. With the float against the retaining ring, carefully lift the open end of the tube up and lower the assembly, float end first, into the tank until the tube rests on the bottom of the tank (Figure 2). Carefully slide the stainless steel reducing bushing, large end first, down over the tube until it rests against the tank opening. Apply UL classified sealant suitable for use with the product in the tank to the outside bushing threads that will be screwed into the tank fitting. Screw the bushing into the tank fitting. Tighten the bushing as required to ensure a proper seal.

SEALING THE STAINLESS STEEL TUBE IN THE TANK OPENING

2. Loosen the gland nut on the male connector. Carefully slide the male connector, 1" NPT end first, down onto the tube until it rests against the bushing. Apply UL classified sealant suitable for use with the product in the tank to the threads of the connector's NPT threads. Screw the connector into the bushing. Tighten the connector as required to ensure a proper seal.



3. Push the tube down until it rests on the tank's bottom. Using a felt marker, make a mark on the tube at the top of the gland nut. Raise the tube until the mark is 1-inch (25.4 mm) above the nut, then hand tighten the gland nut until the tube is held in place (this distance is necessary for expansion and contraction of the tank). Tighten the gland nut one and one quarter full turns beyond hand tight to crimp the ferrules to the tube and create the proper seal. Note that with the bottom clearance set at 1 inch (25.4 mm), the lowest level the probe can measure in the tank is approximately 3.25 inches (82.55 mm) (see Figure 2).

INSTALLING THE PROBE IN THE STAINLESS STEEL TUBE

4. Slide the rubber rain shield onto the probe shaft (narrow end up) and push it all the way up to the probe canister. Gently slide the probe down into the tube until it rests on the bottom of the tube. Slide the rain shield down the shaft until it rests against the top end of the tube. The lower (wide) end of the shield may be a little over the top of the gland nut. Note: the rain shield is intended to keep water out from between the probe's shaft and the inside of the tube so you don't want to force the shield down below the top end of the tube (see Figure 3).

5. Attach the probe cable connector to the mating plug on the top of the probe canister. Hand tighten the connector securely.
6. If required by local regulations, install a protective housing. A typical housing consists of a reducer, 4-inch (101.6 mm) diameter pipe, and union. The final assembly must comply with local codes.
7. The contents of the Cable Seal kit are used to field connect the probe-to-console wiring. Reference the appropriate Site Prep manual for instructions on this procedure.

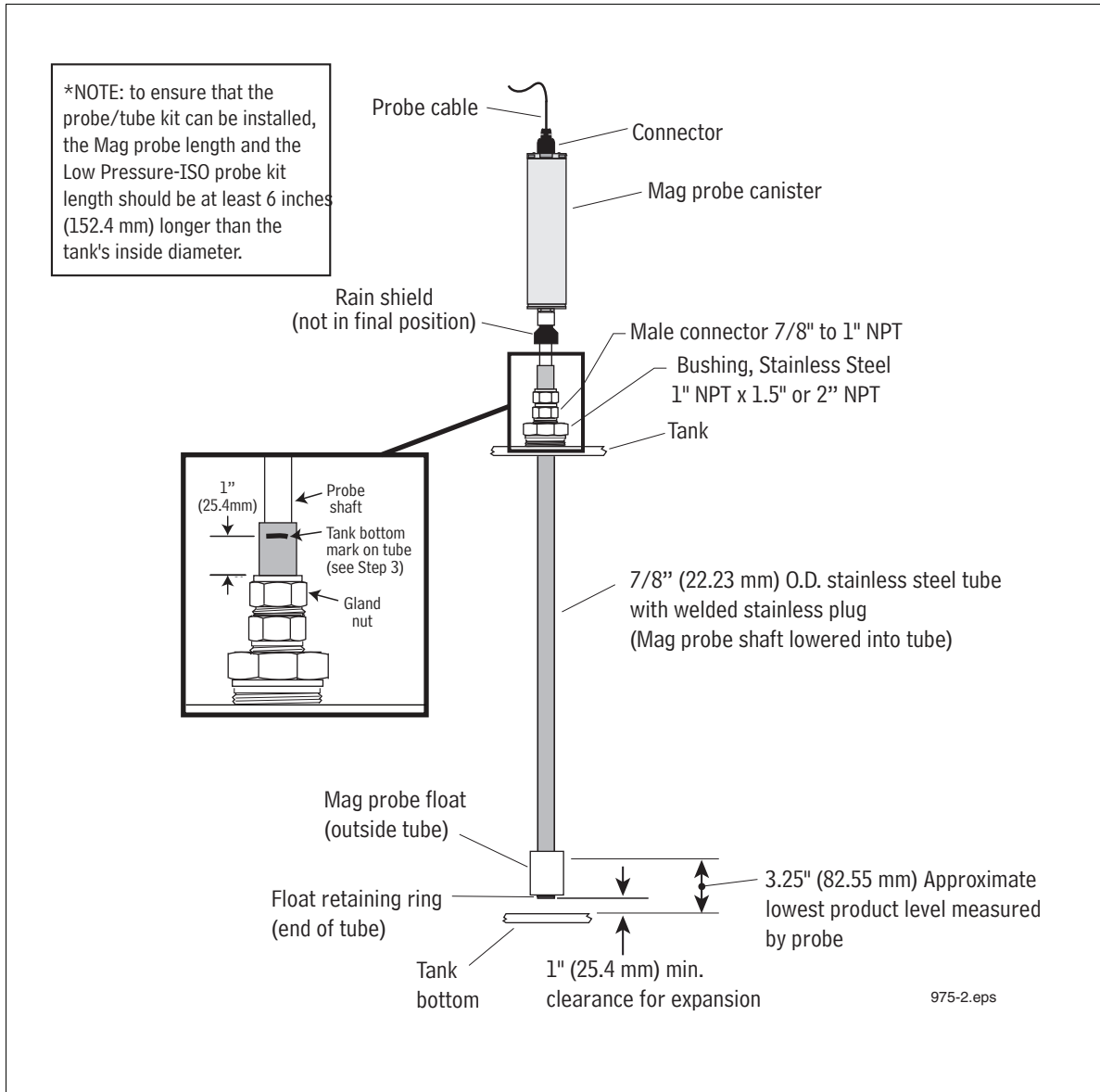

Figure 2. Media Isolated Mag Plus probe installation example

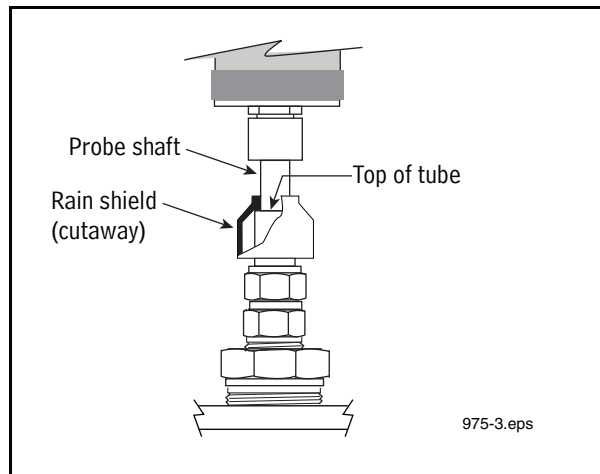

Figure 3. Rain shield installed position

Entering Custom Float Size

At the console, select Custom for float size/type. For the Low Pressure-ISO probe you need to enter a Fuel Offset value of +0001.120¹ (28.45 mm) and an Invalid Fuel value of +0003.250 (82.55 mm). (Water Offset and Water Minimum values are ignored for this probe so no changes are necessary). The probe is now installed and setup.

-
1. On Version 21 and earlier software this offset can be entered in setup by selecting a "Tilt" value of +1.06 (26.93 mm) and a 2-inch (50 mm) float entry.

