

4" Submersible Petroleum Pump

Installation, Operation and Service

Red Jacket[®] Quick-Set[®] Extracta[®] Submersible Pump

Notice

Veeder-Root makes no warranty of any kind with regard to this publication, including, but not limited to, the implied warranties of merchantability and fitness for a particular purpose.

Veeder-Root shall not be liable for errors contained herein or for incidental or consequential damages in connection with the furnishing, performance, or use of this publication.

Veeder-Root reserves the right to change system options or features, or the information contained in this publication.

This publication contains proprietary information which is protected by copyright. All rights reserved. No part of this publication may be photocopied, reproduced, or translated to another language without the prior written consent of Veeder-Root.

Contact Red Jacket Technical Support for additional troubleshooting information at 800-323-1799.

DAMAGE GOODS/LOST EQUIPMENT

Thoroughly examine all components and units as soon as they are received. If any cartons are damaged or missing, write a complete and detailed description of the damage or shortage on the face of the freight bill. The carrier's agent must verify the inspection and sign the description. Refuse only the damaged product, not the entire shipment.

VR must be notified of any damages and/or shortages within 30 days of receipt of the shipment, as stated in our Terms and Conditions.

VEEDER-ROOT'S PREFERRED CARRIER

1. Fax Bill of Lading to V/R Customer Service at 800-234-5350.
2. Call V/R Customer Service at 800-873-3313 with the specific part numbers and quantities that were received damaged or lost.
3. VR will file the claim with the carrier and replace the damaged/missing product at no charge to the customer. Customer Service will work with production facility to have the replacement product shipped as soon as possible.

CUSTOMER'S PREFERRED CARRIER

1. Customer files claim with carrier.
2. Customer may submit a replacement purchase order. Customer Service will work with production facility to have the replacement product shipped as soon as possible.
3. If "lost" equipment is delivered at a later date and is not needed, VR will allow a Return to Stock without a restocking fee.
4. VR will NOT be responsible for any compensation when a customer chooses their own carrier.

RETURN SHIPPING

For the parts return procedure, please follow the instructions in the "General Returned Goods Policy" pages of the "Policies and Literature" section of the Veeder-Root North American Red Jacket Mechanical Products Price Book. Veeder-Root will not accept any return product without a Return Goods Authorization (RGA) number clearly printed on the outside of the package.

RESPONSIBILITIES OF THE INSTALLER AND STATION OWNER

This installation, operation and service instruction manual shall be left with the owner of the service station at which this equipment is installed. Retain these instructions for future use and provide them to persons servicing or removing this equipment.

Introduction

Safety Precautions 1
 Warnings And Instructions 2
 Important Safety Information 2
 Preliminary Precautions..... 2
 Requirements For Use 3
 Operating Precautions..... 3
 Fuel Compatibilities 4
 Leak Detector Installation and Manifold Dimensions 4
 Recommended Floating Suction Installation 6
 Dimensions For Pump Selection 7
 Specifications 8

Installation

Attaching The UMP 13
 Installing The Pump 15
 Conduit Box Wiring 18
 For three Phase Pumps (Without Capacitor)..... 18
 Installing Two Pumps For Tandem Operation 25
 Wiring Single-Phase Tandem Pumps 26
 Wiring Three-Phase Tandem Pumps 27
 Adjusting The Functional Element 28
 To Adjust the Relief Pressure..... 28
 Initial Start-Up Of Pump 29
 NOTE: For Three-Phase Pumps Only!..... 29

Testing The Installation

To Test Piping 31
 To Test Tank 32

Service And Repair

Removing the Pump 33
 Replacing the UMP 34
 Replacing The Quad Seal 37
 Replacing The Check Valve, Spring And Functional Element 40
 Disable the Pump 40
 Replace the Check Valve, Spring and Functional Element..... 40
 Replacing the Capacitor in Packer 41
 Installing a Replacement Extractable Pump 42

Parts Lists

Customer Service Number 45
 Yoke Assembly and Conduit Box Parts 45
 Packer-Manifold Assembly Parts 46
 Pump Parts 48
 Control Boxes 51

Appendix A - FDNY Conditions Of Approval

Figure

Figure 1.	Leak Detector And Manifold Dimensions	5
Figure 2.	Floating Suction Installation	6
Figure 3.	Floating Suction Adapter	6
Figure 4.	Measuring The Tank (See Table 2 For Adjustment Ranges).	7
Figure 5.	Identifying UMP Models By Their End View	12
Figure 6.	Packer/Manifold With Piping Attaching To UMP	13
Figure 7.	Aligning The UMP Gasket	14
Figure 8.	Verifying Pigtail's Female Connector Is Seated Properly	14
Figure 9.	Measuring Tank	15
Figure 10.	Loosening Locking Nut	16
Figure 11.	Adjusting Pump Length	16
Figure 12.	Attaching Return Line Tubing To Pump	17
Figure 13.	Capacitor Wiring Schematic	17
Figure 14.	Conduit Box Wiring	19
Figure 15.	230 VAC Remote Control Box With 110 VAC Coil - Model 880-041-5	20
Figure 16.	Suggested Wiring Diagram Without Optional Control Box	20
Figure 17.	230 Vac Remote Control Box With 110 VAC Coil And Cap - Model 880-045-5/880-046-5	21
Figure 18.	230 VAC Remote Control Box With 230 VAC Coil - Model 880-042-5	22
Figure 19.	Isotrol To IQ System Wiring - 120 Volt Dispenser Signals	23
Figure 20.	Isotrol To IQ System Wiring - 230 Volt Dispenser Signals	24
Figure 21.	Tandem Pumps	25
Figure 22.	Suggested Wiring For Tandem Pumps	26
Figure 23.	Suggested Wiring For Three-Phase Tandem Pumps	27
Figure 24.	Functional Element Cap And Adjustment Screw	28
Figure 25.	Three-Phase Pump Wiring Diagram Examples	30
Figure 26.	Closing The Check Valve	31
Figure 27.	Line Test Port	32
Figure 28.	Packer	33
Figure 29.	Removing The UMP	34
Figure 30.	Replacing The gasket	35
Figure 31.	Verifying Pigtail's Female Connector Is Seated Properly	35
Figure 32.	Electronic Line Leak Detector	37
Figure 33.	Locating 7" Packer O-Ring And Quad Seal	39
Figure 34.	Installing New Quad Seal	39
Figure 35.	Packer With Functional Element	40
Figure 36.	Functional Element O-Rings	41
Figure 37.	Wiring Schematic	43
Figure 38.	Yoke Assembly And Conduit Box Part Identification	45
Figure 39.	Packer-Manifold Assembly Top View - Part Identification	46
Figure 40.	Packer-Manifold Assembly Side View- Part Identification	46
Figure 41.	Pump Parts	48
Figure 42.	880-041-5/880-042-5 Control Box	51
Figure 43.	880-045-5/880-046-5 Control Box	52

Tables

Table 1.	Maximum Specific Gravity and Maximum Viscosity	4
Table 2.	Distance From Eye Bolt To Inlet	8
Table 3.	Electrical Service Information (Use For UMPs Containing A Franklin Motor With End View A)	9
Table 4.	Electrical Service Information (Use For UMPs Containing A	















	Faradyne Motor With End View B)	10
Table 5.	UMP Model Dimensions	11
Table 6.	Applicable UMPs for 4" Standard Packer/Manifolds	13
Table 7.	Approximate Pressures at shut-off	29
Table 8.	Yoke Assembly and Conduit Box Parts List	45
Table 9.	Packer-Manifold Assembly Parts List	47
Table 10.	Pump Parts List	49
Table 11.	880-041-5 Control Box W/115V Coil (60 Hz)	51
Table 12.	880-042-5 Control Box W/230V Coil (50/60 Hz)	51
Table 13.	880-045-5 1/3 & 3/4 HP Control Box W/Cap (115V Coil)	52
Table 14.	880-046-5 All 1-1/2 HP Control Box W/Cap (115V Coil)	52

Introduction

This manual contains installation, operation, and service information for the Red Jacket 4-inch Standard Submersible Petroleum and AG pump.

Safety Precautions

The following safety symbols are used throughout this manual to alert you to important safety hazards and precautions

 <p>EXPLOSIVE Fuels and their vapors are extremely explosive if ignited.</p>	 <p>FLAMMABLE Fuels and their vapors are extremely flammable.</p>
 <p>ELECTRICITY High voltage exists in, and is supplied to, the device. A potential shock hazard exists.</p>	 <p>TURN POWER OFF Live power to a device creates a potential shock hazard. Turn Off power to the device and associated accessories when servicing the unit.</p>
 <p>WARNING indicates a hazardous situation which, if not avoided, could result in death or serious injury.</p>	 <p>CAUTION indicates a hazardous situation which, if not avoided, could result in minor or moderate injury.</p>
 <p>READ ALL RELATED MANUALS Knowledge of all related procedures before you begin work is important. Read and understand all manuals thoroughly. If you do not understand a procedure, ask someone who does</p>	 <p>NOTICE is used to address practices not related to physical injury.</p>
 <p>WEAR EYE PROTECTION Wear eye protection when working with pressurized fuel lines to avoid possible eye injury.</p>	 <p>WEAR GLOVES Wear gloves to protect hands from irritation or injury.</p>
 <p>NO POWER TOOLS Sparks from power tools (such as drills) can ignite fuels and their vapors.</p>	 <p>NO SMOKING Sparks and embers from burning cigarettes or pipes can ignite fuels and their vapors.</p>
 <p>NO OPEN FLAMES Open flames from matches, lighters, welding torches, etc. can ignite fuels and their vapors</p>	 <p>TURN OFF CELL PHONES/PAGERS Sparks from electronic devices in the vicinity of gasoline storage tanks could cause an explosion or fire resulting in bodily injury or death.</p>

⚠ WARNING



This product operates in the highly combustible atmosphere of a gasoline storage tank. **FAILURE TO COMPLY WITH THE FOLLOWING WARNINGS AND SAFETY PRECAUTIONS COULD CAUSE DAMAGE TO PROPERTY, ENVIRONMENT, RESULTING IN SERIOUS INJURY OR DEATH.**

1. All installation work must comply with the latest issue of the National Electrical Code (NFPA 70), Code for Motor Fuel Dispensing Facilities and Repair Garages (NFPA) 30A, and any national, state, and local code requirements that apply.
2. Turn off, tag, and lockout power to the STP before connecting or servicing the STP.
3. Before installing pipe threads apply an adequate amount of fresh, UL classified for petroleum, non-setting thread sealant.
4. To protect yourself and others from serious injury, death, or substantial property damage, carefully read and follow all warnings and instructions in this manual.
5. When servicing unit use non-sparking tools and use caution when removing or installing equipment to avoid generating a spark.

Warnings And Instructions

IMPORTANT SAFETY INFORMATION

⚠ WARNING This section introduces the hazards and safety precautions associated with installing, inspecting, maintaining or servicing this product. Before performing any task on this product, read this safety information and the applicable sections in this manual, where additional hazards and safety precautions for your task will be found. Fire, explosion, electrical shock or pressure release could occur and cause death or serious injury, if these safe service procedures are not followed.

PRELIMINARY PRECAUTIONS

⚠ WARNING You are working in a potentially dangerous environment of flammable fuels, vapors, and high voltage or pressures. Only trained or authorized individuals knowledgeable in the related procedures should install, inspect, maintain or service this equipment.



Read the Manual

Read, understand and follow this manual and any other labels or related materials supplied with this equipment. If you do not understand a procedure, call 1-800-323-1719 to locate a qualified technician. It is imperative to your safety and the safety of others to understand the procedures before beginning work. **Make sure your employees and any service contractors read and follow the instructions.**

Follow the Regulations

Applicable information is available in National Fire Protection Association (NFPA) 30A; *Code for Motor Field Dispensing Facilities and Repair Garages*, NFPA 70; *National Electrical Code* (NEC), Occupational Safety and Hazard Association (OSHA) regulations and federal, state, and local codes. All these regulations must be followed. Failure to install, inspect, maintain or service this equipment in accordance with these codes, regulations and standards may lead to legal citations with penalties or affect the safe use and operation of the equipment.

Prevent Explosions and Fires

Fuels and their vapors will explode or burn, if ignited. Spilled or leaking fuels cause vapors. Even filling customer tanks will cause potentially dangerous vapors in the vicinity of the dispenser or island.

Working Alone

It is highly recommended that someone who is capable of rendering first aid be present during servicing. Familiarize yourself with Cardiopulmonary Resuscitation (CPR) methods, if you work with or around high voltages. This information is available from the American Red Cross. Always advise the station personnel about where you will be working, and caution them not to activate power while you are working on the equipment. Use the OSHA Lockout/Tagout procedures. If you are not familiar with this requirement, refer to OSHA documentation.

Working With Electricity Safely

Ensure that you use safe and established practices in working with electrical devices. Poorly wired devices may cause a fire, explosion or electrical shock. Ensure that grounding connections are properly made. Ensure that you do not pinch wires when replacing covers. Follow OSHA Lockout/Tagout requirements. Station employees and service contractors need to understand and comply with this program completely to ensure safety while the equipment is down. Before you start work, know the location of the Emergency Power Cutoff Switch (the E-STOP). This switch cuts off power to all fueling equipment and submerged turbine pumps and is to be used in the event of an emergency. The buttons on the console at the cashier's station WILL NOT shut off electrical power to the pump/dispenser. This means that even if you press a button on the console labeled EMERGENCY STOP, ALL STOP, PUMP STOP, or something similar, fuel may continue to flow uncontrolled.

Hazardous Materials

Some materials may present a health hazard if not handled correctly. Ensure that you clean hands after handling equipment. Do not place any equipment in the mouth.

⚠ WARNING FAILURE TO COMPLY WITH THE FOLLOWING WARNINGS AND SAFETY PRECAUTIONS COULD CAUSE DAMAGE TO PROPERTY, ENVIRONMENT, RESULTING IN SERIOUS INJURY OR DEATH.



FIRE HAZARD! Do **NOT** use **power tools** (Class I Division I and Class I Division II) during the installation or maintenance of equipment. Sparking could ignite fuel or vapors, resulting in fire.



CHEMICAL EXPOSURE HAZARD! Wear appropriate **safety equipment** during installation or maintenance of equipment. Avoid exposure to fuel and vapors. Prolonged exposure to fuel may cause severe skin irritations and possible burns.

REQUIREMENTS FOR USE

- The STP is designed for use only at facilities dispensing motor fuels.
- Application of STP must be consistent with NFPA Code 30A, OSHA regulations, and federal, state and local fire codes, and other applicable local regulations.
- The selection of any Veeder-Root product must be based upon physical specifications and limitations and the product's compatibility with the materials to be handled. Veeder-Root makes no warranty of fitness for a particular purpose.
- All Veeder-Root products should be used in accordance with applicable federal, state and local laws, ordinances and regulations.

OPERATING PRECAUTIONS



- **NO SMOKING.** Extinguish all open flames and pilot lights, such as on RV appliances.
- **TURN OFF** cell phones and other electronic devices to avoid distractions while fueling.
- **GASOLINE CAN BE HARMFUL OR FATAL IF SWALLOWED.** Long-term exposure may cause cancer. Keep eyes and skin away from liquid gasoline and gasoline vapors. Avoid prolonged breathing of gasoline vapors.

Fuel Compatibilities

Pumps are designed to operate in a Class 1, Group D atmosphere and in accordance with CENELEC standard and the European Directive 94/9/EC "Equipment for Potentially Explosive Atmosphere" (II 2G Ex IIA T4).

All Models of the Standard STP are UL Listed for the Following Fuel Compatibility						
Diesel	Gasoline	Gasoline and up to				
		10% Ethanol	15% Methanol	20% MTBE	20% ETBE	20% TAME

The Standard STP is designed to be compatible with 100 percent gasoline, or diesel and 80 percent gasoline with 20 percent methanol, ethanol, TAME, ETBE, or MTBE. All UMPs having the model numbers including the AG prefix are designed to be compatible with 100 percent gasoline, methanol, diesel, 90 percent ethanol with 10 percent gasoline and 80 percent gasoline with 20 percent TAME, ETBE, or MTBE (See Table 1 for UMP models and working parameters).

Table 1. Maximum Specific Gravity and Maximum Viscosity

UMP Model	Maximum Specific Gravity	Maximum Viscosity
AGUMP33R1, UMP33R1	.95	70SSU at 60°F (15°C)
AGUMP75S1, UMP75S1	.95	70SSU at 60°F (15°C)
AGUMP150S1, UMP150S1	.95	70SSU at 60°F (15°C)
AGUMP75S3-3, UMP75S3-3	.95	70SSU at 60°F (15°C)
AGUMP150S3-3, UMP150S3-3	.95	70SSU at 60°F (15°C)
X3AGUMP150S1, X3UMP150S1	.87	70SSU at 60°F (15°C)
AGUMP75S17-3, UMP75S17-3	.95	70SSU at 60°F (15°C)
AGUMP150S17-3, UMP150S17-3	.95	70SSU at 60°F (15°C)
X4AGUMP150S17, X4UMP150S17	.86	70SSU at 60°F (15°C)
X4GUMP150S3, X4UMP150S3	.86	70SSU at 60°F (15°C)

The Quick-Set feature is an adjustable column pipe and electrical conduit that allows the overall length to be adjusted to a wide range of overall pump lengths. By loosening a collet on the column pipe, the length of the ump may be varied by extending or retracting the column pipe.

Four Quick-Set sizes are available, covering most pump length requirements, for precise lengths, see the sizing charts within this chapter.

Leak Detector Installation and Manifold Dimensions

Figure 1 shows several manifold views of the Standard pump.

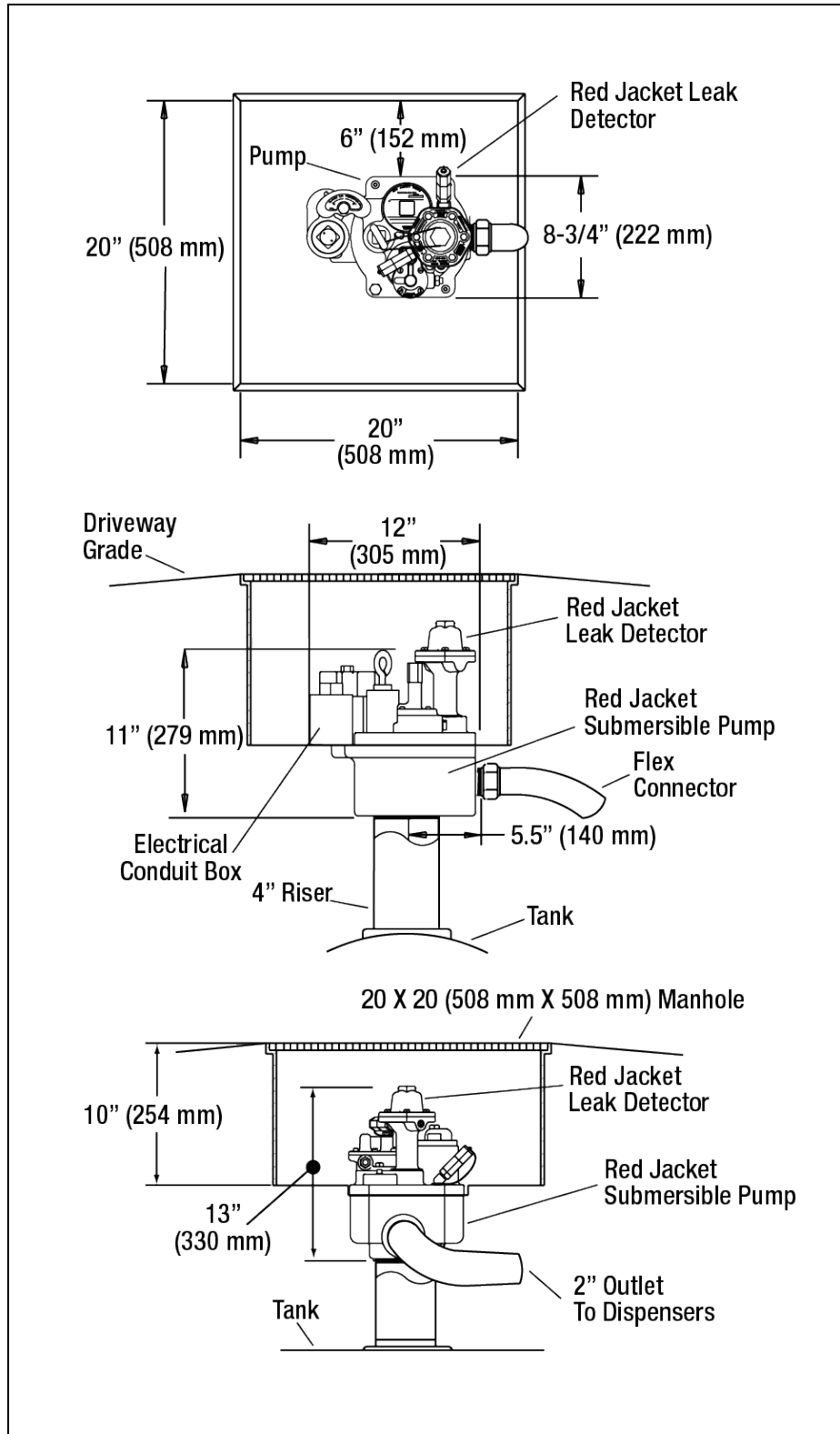

Figure 1. Leak Detector And Manifold Dimensions

Recommended Floating Suction Installation

Figure 2 is an example of a floating suction installation. The floating suction arm can be mounted to pump previous to installing in tank.

NOTICE Veeder-Root supplies adapter only, not the apparatus.

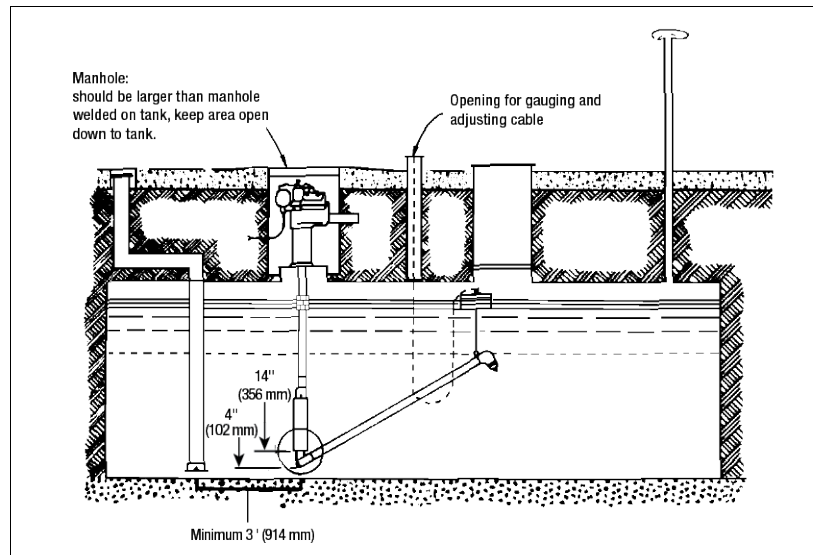

Figure 2. Floating Suction Installation

Figure 3 is an enlarged view within the circle in the above figure.

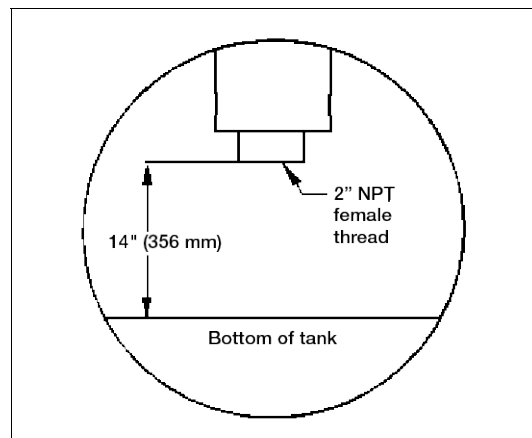

Figure 3. Floating Suction Adapter

Easy service access is provided by unbolting manhole lid through which pump is mounted and removing entire assembly. Use proper thread sealant and insert gasket between flanges of floating suction and pump. This prevents hindrance to pump performance when product level is below this point.

NOTICE Red jacket pumps are centrifugal type pumps and are not designed to pump product when the level is below the bottom end of the UMP.

Dimensions For Pump Selection

Figure 4 shows the dimensions needed to ensure a correctly sized pump.

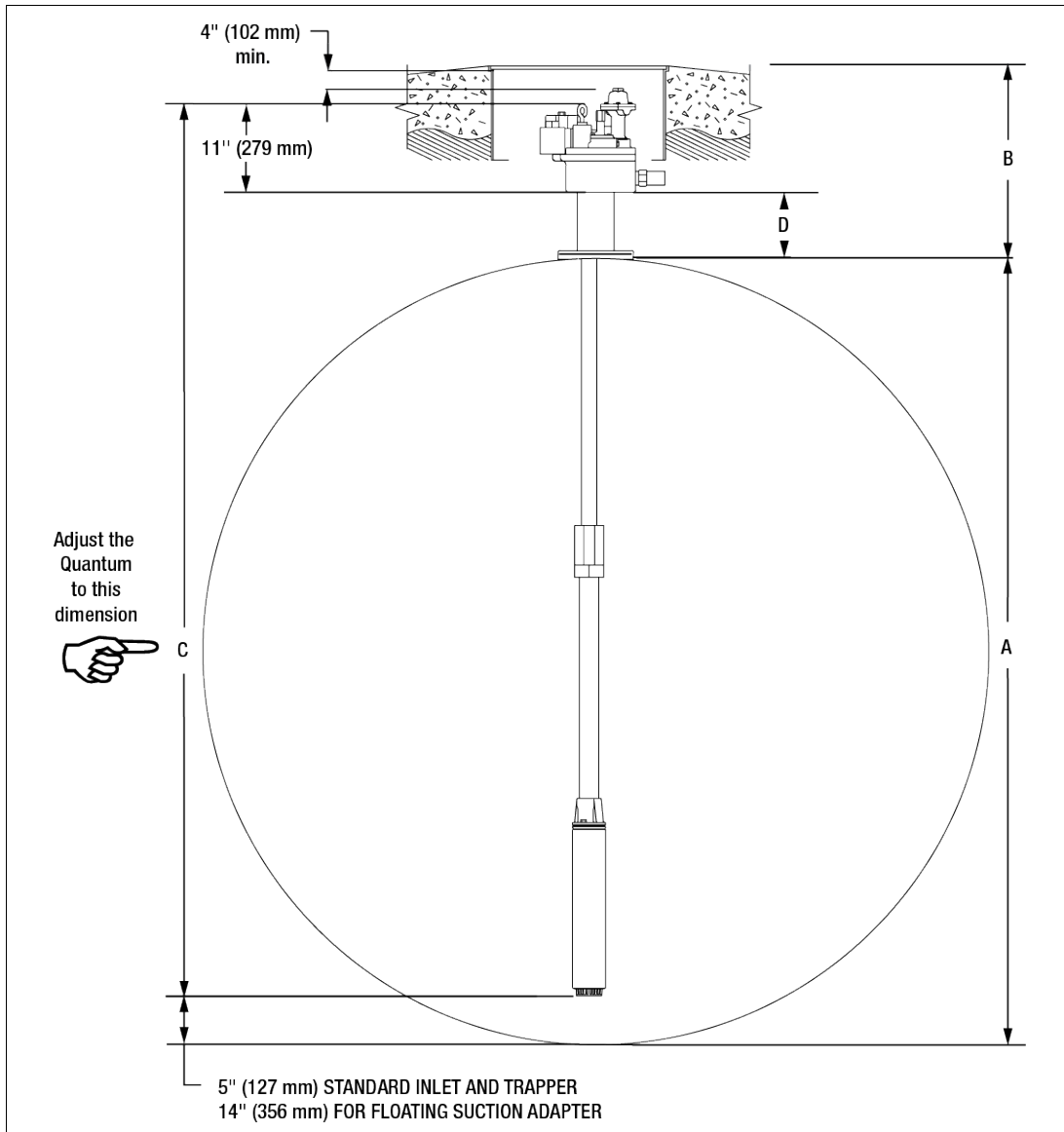

Figure 4. Measuring The Tank (See Table 2 For Adjustment Ranges).

NOTICE Distance between centerline of pump motor and centerline of bottom fill tube should be 3 feet (914 mm) minimum. Air locking of pump after product delivery may occur at distances less than this.

Specifications

Table 2 shows the adjustable pump lengths by model number

Table 2. Distance From Eye Bolt To Inlet

MODEL#	COMPRESSED		EXTENDED	
	in	mm	in	mm
P33R1T1	68.5	1740	95.5	2426
P33R1T2	91.5	2324	125.5	3188
P33R1T3	125.5	3188	192.5	4890
P33R1T4	125.5	3188	159.5	4051
P75S1T1	71.0	1803	98.0	2489
P75S1T2	94.0	2387	128.0	3251
P75S1T3	128.0	3251	195.0	4953
P75S1T4	128.0	3251	162.0	4115
P150S1T1	73.5	1865	100.5	2551
P150S1T2	96.5	2450	130.5	3313
P150S1T3	130.5	3313	197.5	5015
P150S1T4	130.5	3313	164.5	4177
X3P150S1T1	74.5	1887	101.5	2573
X3P150S1T2	97.5	2471	131.5	3335
X3P150S1T3	131.5	3335	198.5	5037
X3P150S1T4	131.5	3335	165.5	4199
P75S3-3T1	73.0	1853	100.0	2539
P75S3-3T2	96.0	2437	130.0	3301
P75S3-3T3	130.0	3301	197.0	5003
P75S3-3T4	130.0	3301	164.0	4165
P150S3-3T1	75.0	1907	102.0	2592
P150S3-3T2	98.0	2491	132.0	3354
P150S3-3T3	132.0	3354	199.0	5056
P150S3-3T4	132.0	3354	166.0	4218
X4P150S3T1	75.5	1920	102.5	2606
X4P150S3T2	98.5	2504	132.5	3368
X4P150S3T3	132.5	3368	199.5	5073
X4P150S3T4	132.5	3368	166.5	4232
P75S17-3T1	72.0	1828	99.0	2514
P75S17-3T2	95.0	2412	129.0	3276
P75S17-3T3	129.0	3276	196.0	4977
P75S17-3T4,	129.0	3276	163.0	4139
P150S17-3T1	74.0	1878	101.0	2564
P150S17-3T2	97.0	2462	131.0	3326
P150S17-3T3	131.0	3326	198.0	5028
P150S17-3T4	131.0	3326	165.0	4189

Table 2. Distance From Eye Bolt To Inlet

MODEL#	COMPRESSED		EXTENDED	
	in	mm	in	mm
X4P150S17T1	74.5	1892	101.5	2578
X4P150S17T2	97.5	2476	131.5	3340
X4P150S17T3	131.5	3340	198.5	5041
X4P150S17T4	131.5	3340	165.5	4203

Table 3 shows pump electrical service requirements for UMPs with end view A and Table 4 shows pump electrical service requirements for UMPs with end view B.

Table 3. Electrical Service Information (Use For UMPs Containing A Franklin Motor With End View A)

Required power supply rating for 60 Hz, 1 phase motors is 208 - 230 Vac. For 50 Hz, 1 phase motors, required rating is 220 - 240 Vac. 3 phase motors required rating is 380 - 415 Vac.

UMP Model No.	HP	Hz	PH	Voltage Fluctuation Range		Max. Load Amps	Locked Rotor Amps	Winding Resistance (Ohms)			Capacitor Kit (µF) or Heaters (KXX)
				Min.	Max.			Black-Orange	Red-Orange	Black-Red	
AGUMP33R1, UMP33R1	1/3	60	1	200	250	4	13	7.7 - 9.4	17.4 - 21.2	25 - 30.7	144-224-5 (17.5)
AGUMP75S1, UMP75S1	3/4	60	1	200	250	6.5	25	2.9 - 3.6	14.9 - 18.2	17.7 - 21.9	144-224-5 (17.5)
AGUMP150S1, UMP150S1	1-1/2	60	1	200	250	10.5	37	2 - 2.5	11.6 - 14.2	13.5 - 16.8	144-225-5 (25)
X3AGUMP150S1, X3UMP150S1	1/1/2	60	1	200	250	10.5	37	2 - 2.5	11.6 - 14.2	13.5 - 16.8	144-225-5 (25)
AGUMP75S3-3, UMP75S3-3	3/4	50	1	200	250	5.8	17	3.6 - 4.5	20.4 - 25	23.9 - 29.6	144-224-5 (17.5)
AGUMP150S3-3, UMP150S3-3	1-1/2	50	1	200	250	10	28	2.5 - 3.1	11.5 - 14	13.9 - 17.2	144-225-5 (25)
X4AGUMP150S3, X4UMP150S3	1-1/2	50	1	200	250	10	28	2.5 - 3.1	11.5 - 14	13.9 - 17.2	144-225-5 (25)
AGUMP75S17-3, UMP75S17-3	3/4	50	3	342	457	2.2	11	25.8 - 32.4	25.8 - 32.4	25.8 - 32.4	K26
AGUMP150S17-3, UMP150S17-3	1-1/2	50	3	342	457	3.8	15.8	13.1 - 16.4	13.1 - 16.4	13.1 - 16.4	K33
X4AGUMP150S17, X4UMP150S17	1-1/2	50	3	342	457	3.8	15.8	13.1 - 16.4	13.1 - 16.4	13.1 - 16.4	K33

Table 4. Electrical Service Information (Use For UMPs Containing A Faradyne Motor With End View B)

Required power supply rating for 60 Hz, 1 phase motors is 208 - 230 Vac. For 50 Hz, 1 phase motors, required rating is 220 - 240 Vac.
3 phase motors required rating is 380 - 415 Vac.

UMP Model No.	HP	Hz	PH	Voltage Fluctuation Range		Max. Load Amps	Locked Rotor Amps	Winding Resistance (Ohms)			Capacitor Kit (µF)
				Min.	Max.			Black-Orange	Red-Orange	Black-Red	
AGUMP33R1, UMP33R1	1/3	60	1	200	250	4	10	8.9 - 10.8	11.5 - 13.9	20.2 - 24.5	144-224-5 (17.5)
AGUMP75S1, UMP75S1	3/4	60	1	200	250	6.5	19	4.7 - 5.7	7.1 - 8.6	11.7 - 14.1	144-224-5 (17.5)
AGUMP150S1, UMP150S1	1-1/2	60	1	200	250	10.5	33	2.8 - 3.4	6.8 - 8.2	9.4 - 11.3	144-225-5 (25)
X3AGUMP150S1, X3UMP150S1	1/1/2	60	1	200	250	10.5	33	2.8 - 3.4	6.8 - 8.2	9.4 - 11.3	144-225-5 (25)
AGUMP75S3-3, UMP75S3-3	3/4	50	1	200	250	5.8	18	5.2 - 6.3	10.3 - 12.5	15.4 - 18.6	144-224-5 (17.5)
AGUMP150S3-3, UMP150S3-3	1-1/2	50	1	200	250	10	31	2.8 - 3.4	13.4 - 16.3	16.1 - 19.5	144-225-5 (25)
X4AGUMP150S3, X4UMP150S3	1-1/2	50	1	200	250	10	31	2.8 - 3.4	13.4 - 16.3	16.1 - 19.5	144-225-5 (25)

When using a Red Jacket IQ™ Control Unit with an UMP containing a Faradyne motor, IQ software 805-001C (Version3.2) or newer, is required for proper operation of the system. The UMPs will have an 'FM' designation printed on the UMP shell. Software upgrade kit part number is 410600-001.

Table 5 lists pump weights and lengths.

NOTICE The weights and lengths listed below are approximate values and will vary due to manufacturing tolerances.

The optional trapper intake screen is available as a field installed accessory. Trapper options will change the length of the UMP by 3.3 inches (83 mm). For installation instructions, see Red Jacket installation instructions #051-256-1. For models with Floating Suction Adapter, add 2-3/8 inches (59 mm) and 4 pounds (1.8 kg).

Table 5. UMP Model Dimensions

UMP Model	HP	Franklin Motors (Use these lengths for UMPs with end view A shown in Figure 5)		Faradyne Motors (Use these lengths for UMPs with end view B shown in Figure 5)		Weight	
		in.	mm	in.	mm	lb.	kg
UMP33U1, AGUMP33R1	1/3	15-1/2	390	15-3/8	391	24	11
UMP75U1, AGUMP75S1	3/4	17-3/4	447	17-5/8	448	28	12.7
UMP75U3-3, AGUMP75S3-3	3/4	20	507	19-7/8	505	30.5	13.9
UMP75U17-3, AGUMP75U17-3	3/4	19-1/4	489	----	----	28	12.7
UMP150U1, AGUMP150S1	1-1/2	20-1/2	519	20-5/8	524	34	15.5
X3P150U1, X3AGUMP150S1	1-1/2	21-1/4	540	21-1/2	546	35	15.8
UMP150U3-3, AGUMP150S3-3	1-1/2	22-1/4	565	22-1/4	565	34	15.5
X4P150U3, X4GUMP150S3	1-1/2	22-3/4	576	22-7/8	581	35	15.9
UMP150U17-3, AGUMP150S17-3	1-1/2	21	532	----	----	31	14.1
X4P150U17, X4AGUMP150S17	1-1/2	21-1/2	547	----	----	32	14.5

Figure 5 identifies UMP models by their end view.

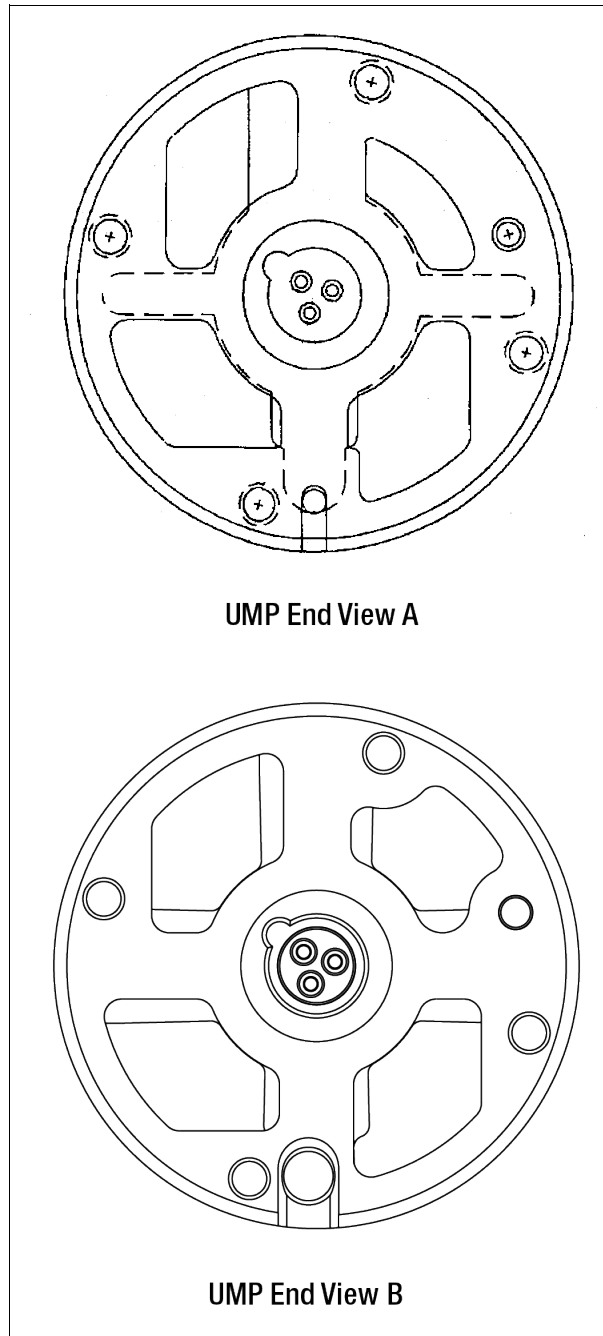

Figure 5. Identifying UMP Models By Their End View

Installation

Attaching The UMP

Table 6 lists the applicable UMPs for each packer/manifold.

Table 6. Applicable UMPs for 4" Standard Packer/Manifolds

Packer/Manifold	UMP	Packer/Manifold	UMP
AGP33R1	AGUMP33R1	P150S3-3	UMP150S3-3
P33R1	UMP33R1	X4AGP150S3	X4AGUMP150S3
AGP75S1	AGUMP75S1	X4P150S3	X4UMP150S3
P75S1	UMP75S1	AGP75S17-3	AGUMP75S17-3
AGP150S1	AGUMP150S1	P75S17-3	UMP75S17-3
P150S1	UMP150S1	AGP150S17-3	AGUMP15017-3
X3AGP150S1	X3AGUMP150S1	P150S17-3	UMP15017-3
X3P150S1	X3UMP150S1	X4AGP150S17	X4AGUMP150S17
AGP75S3-3	AGUMP75S3-3	X4P150S17	X4UMP150S17
P75S3-3	UMP75S3-3		
AGP150S3-3	AGUMP150S3-3		

The UMP is identified by the model number marked on the shell. The packer/manifold assembly with attached piping is identified by the catalog number on the capacitor cover nameplate. The catalog number will be followed by T1, T2, T3, or T4 on adjustable length pumps or a four-digit number indicating the original pump length in feet and inches (a 9 ft. 6 inch [2896 mm] pump would have 0906 after the model number).

The attachment hardware kit to be used to connect the UMP to the Packer/Manifold assembly piping consists of four Grade 5, 5/16 -18 x 1" socket head cap screws, four 5/16 spring lock washers and one discharge head gasket. It is identified by the kit number (144-328-4) marked on the bag (see Figure 6).

NOTICE Suggested tools (non-sparking) include a 3/4" wrench, pipe wrench, 1/4" allen wrench, 9/16" wrench, screw driver, wire cutter and wire stripper.

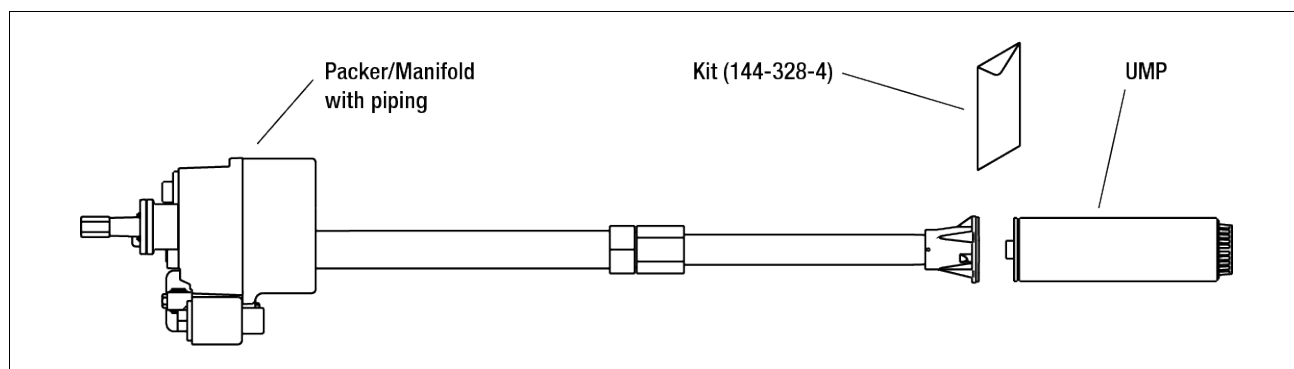

Figure 6. Packer/Manifold With Piping Attaching To UMP

1. Place the new gasket on the new UMP so that all holes align (see Figure 7).

CAUTION Gaskets from competitive UMPs will not seal properly and performance will be reduced.

2. Visually inspect the pigtail connector in the discharge head. Replace if damaged. Be certain the indexing tab of the pigtail is seated in the notch of the discharge head.

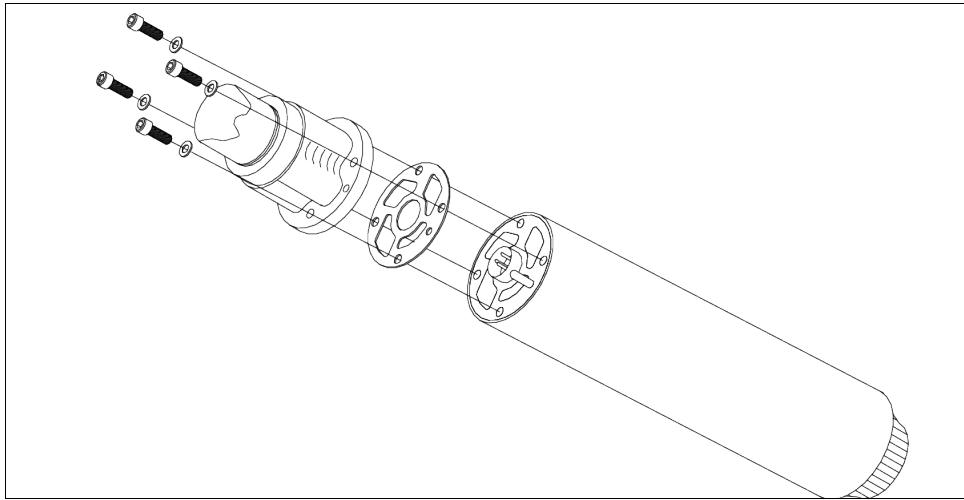

Figure 7. Aligning The UMP Gasket

3. Lubricate the o-ring and pigtail with petroleum based jelly.
4. Align the UMP positioning dowel and boss with the proper holes in the discharge head and push the UMP into position using hand force only (see Figure 8). The UMP should be snug against the discharge head prior to installing the UMP retaining bolts.

WARNING Use hand force to put the UMP onto the discharge head. If the UMP does not seat snug against the discharge head, remove the UMP and correct the problem.

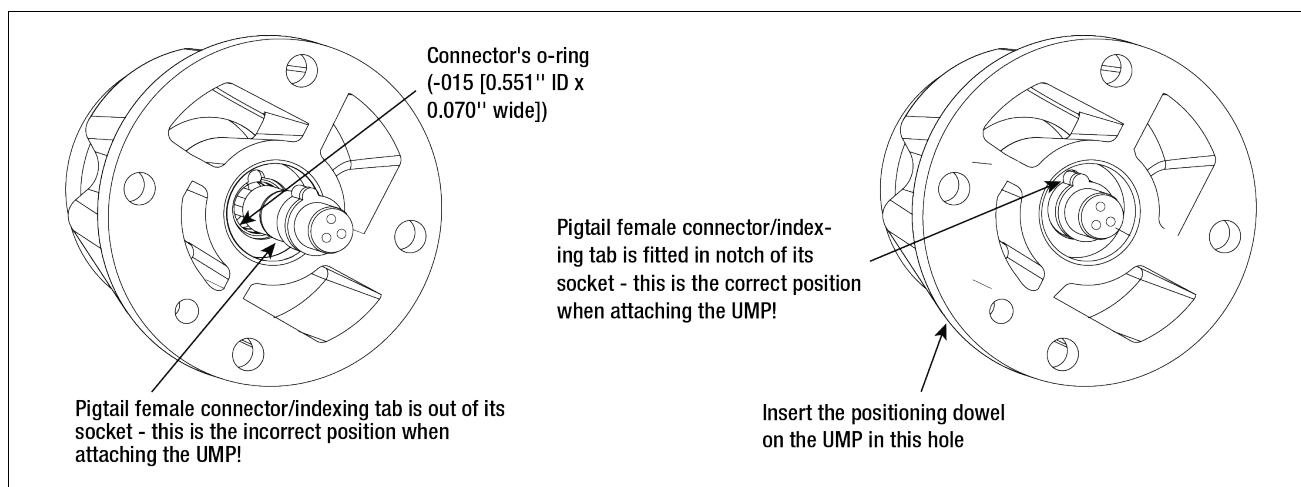

Figure 8. Verifying Pigtail's Female Connector Is Seated Properly

5. Install the UMP retaining bolts and lock washers (see Figure 7). Snug and then torque the bolts using a cross pattern. Torque to 7 ft-lb. (11 N•m).

▲WARNING Do not use the bolts to pull the UMP into position. Use the cross pattern to snug and torque bolts. Do not over torque the bolts.

Installing The Pump

 When servicing equipment, use non-sparking tools and use caution when removing or installing equipment to avoid generating a spark.

NOTES:

- Red Jacket petroleum pumps are designed to operate in a Class 1, Group D atmosphere.
 - The manufacturer may recommend new specifications and installation instructions.
 - The product temperature must not exceed 105°F (41°C) because the thermal overload protectors in the submersible motors may trip.
1. Install the riser pipe into the 4-inch tank opening. Apply an adequate amount of fresh, UL classified for petroleum, non-setting thread sealant. Tighten the riser pipe in the tank until watertight.
 2. Measure the distance from the bottom of the tank to the top of the 4 inch riser pipe as shown in Figure 9. Confirm the installed length of the pump maintains adequate clearance from the pump inlet to the bottom of the tank (see Figure 4).

FOR FIXED LENGTH PUMPS, SKIP STEPS 3 - 6 AND THEN FOLLOW STEPS 7 - 10.

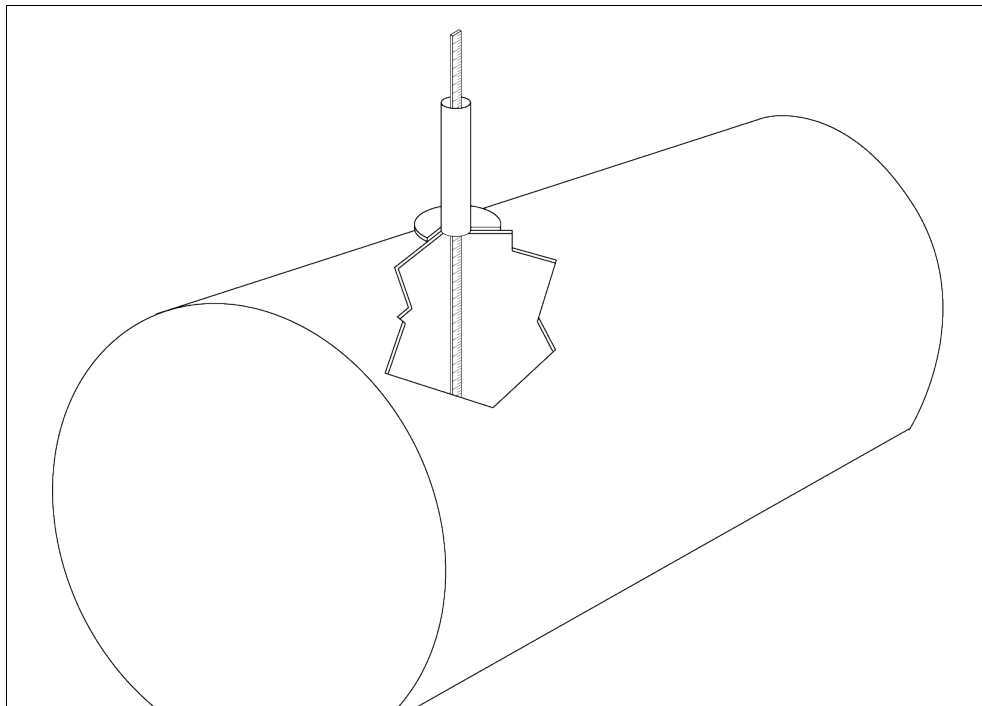

Figure 9. Measuring Tank

3. Uncoil the pigtail and lay it flat so it will feed into the packer without knotting or kinking.
4. Loosen the clinch assembly starting by unscrewing the set screw in the side of locking nut, then backing off the locking nut (see Figure 10). A slight twisting of the UMP will loosen the seals and facilitate adjusting it to the correct length.

NOTICE Do not rotate piping beyond 1/4 turn.

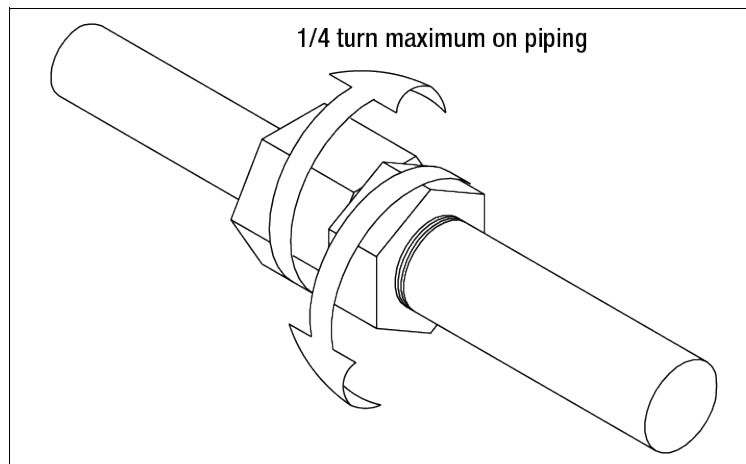

Figure 10. Loosening Locking Nut

5. Referencing Figure 11, pull the UMP end until the distance between the bottom of the manifold and the bottom of the UMP is 5 inches (125 mm) (15 inches [381 mm] for floating suction) shorter than the distance measured in Step 2.

NOTICE If UMP is equipped with floating suction adapter, see section entitled “Recommended Floating Suction Installation” on page 6.

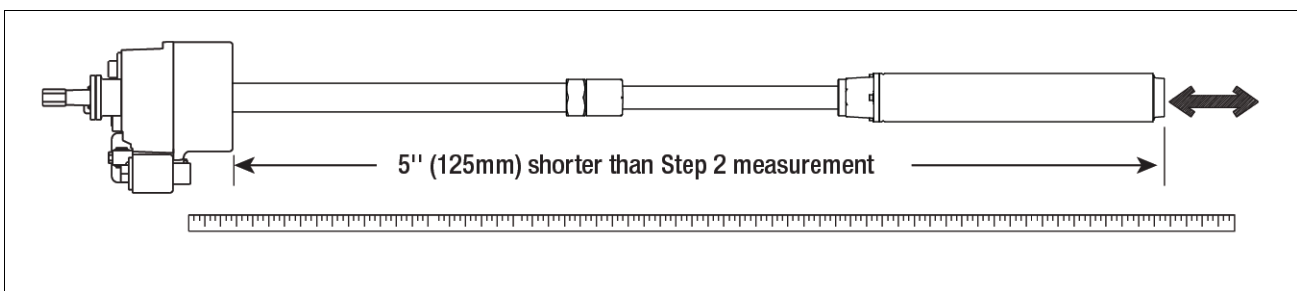

Figure 11. Adjusting Pump Length

⚠ WARNING Take care not to damage the pigtail. If pump is to be adjusted shorter, tension must be kept on pigtail to eliminate kinking.

6. Tighten the column pipe locking nut and torque to 150 ft-lb. (200 N•m) minimum, then torque the setup screw in the locking nut to 30 - 35 in. lb. (3.5 - 4 N•m).

NOTICE Return line should be installed on every application to reduce nuisance trips of electronic tank monitoring.

7. Attach tubing to barbed fitting, secure with clamp.
8. Lay the tubing beside the column pipe. Stop 1 - 3 inches (25 - 76 mm) above the discharge head.
9. Secure the siphon return line tube to the column pipe with tie straps. Locate the tie straps approximately 6 inches (152 mm) from the packer, 6 inches from the discharge head and in the middle of the tubing (see Figure 12).

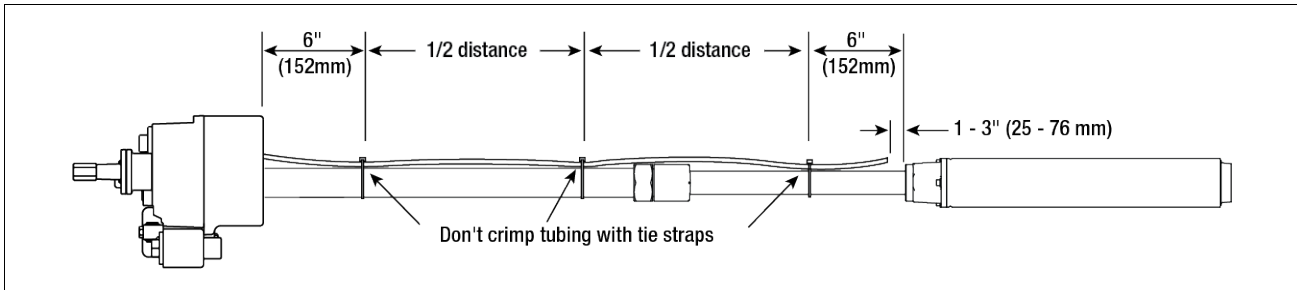

Figure 12. Attaching Return Line Tubing To Pump

10. Remove cover from wiring compartment.
11. Pull pigtail wires into wiring compartment.
12. Cut pigtail wires leaving approximately 8 inches (200 mm) hanging out of wiring compartment.
13. Strip insulation off all wires 3/8 inch (10 mm).
14. Using supplied wire nuts, attach like colored pump pigtail wires to like colored electrical connector wires as shown in Figure 13.

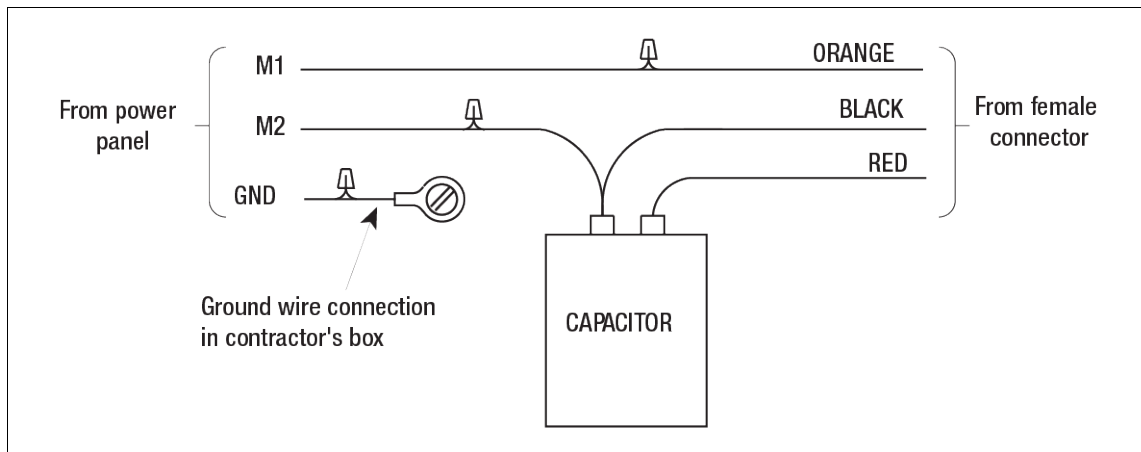

Figure 13. Capacitor Wiring Schematic

15. Install excess wire into wiring compartment. Replace wiring compartment cover. Torque to 35 ft-lb (50 N•m). Thread sealant should not be used.
16. Install eyebolt plug, using an adequate amount of fresh, UL classified for petroleum, non-setting thread sealant, and torque to 50 ft-lb (70 N•m).
17. Apply an adequate amount of fresh, UL classified for petroleum, non-setting thread sealant to the threads of the riser pipe.



Confirm that the lifting eyebolt is properly torqued to 10 ft-lbs (13.6 N•m) with a minimum of 6 full threads installed. Occasionally, eyebolts are removed after pump installation and corrosion may occur in the threaded areas of the wiring compartment cover (eyebolt plug) and the eyebolt. If corrosion has occurred, the cover and eyebolt should be replaced.

18. Utilize the lifting eyebolt to suspend the pump vertically and then install the pump onto the riser pipe until watertight and in alignment with the piping to the dispensers.

Conduit Box Wiring



Disconnect, lock out, and tag power at the panel before servicing the pump.

1. Connect electrical conduit approved fittings to conduit box.
2. Remove cover from conduit box
3. Connect wires from power supply to wires in the conduit box. Install ground wire from power panel (see Figure 14) as shown. Thread sealant required on single box.
4. For Dual Box: Inspect o-rings on access covers, replace if necessary. Lubricate o-rings with petroleum based jelly. Reinstall access covers. Torque 35-ft-lbs (50 N•m). Do not use thread sealant on dual box.
5. For Single Box: Apply an adequate amount of fresh, UL classified for petroleum, non-setting thread sealant to the 2" NPT plug and torque until watertight.

For three Phase Pumps (Without Capacitor)

See Figure 17 for Steps 1 through 4.

1. Connect the orange wire from the manifold's female connector to M1 from the output of the control box.
2. Connect the black wire from the manifold's female connector to M2 from the output of the control box.
3. Connect the red wire from the manifold's female connector to M3 from the output of the control box.
4. Connect the ground wire from the power panel to the ground screw in the conduit box.
5. For Dual Box: Inspect o-rings on access covers, replace if necessary. Lubricate o-rings with petroleum based jelly. Reinstall access covers. Torque 35-ft-lbs (50 N•m). Do not use thread sealant on dual box.
6. For Single Box: Apply an adequate amount of fresh, UL classified for petroleum, non-setting thread sealant to the 2" NPT plug and torque until watertight.

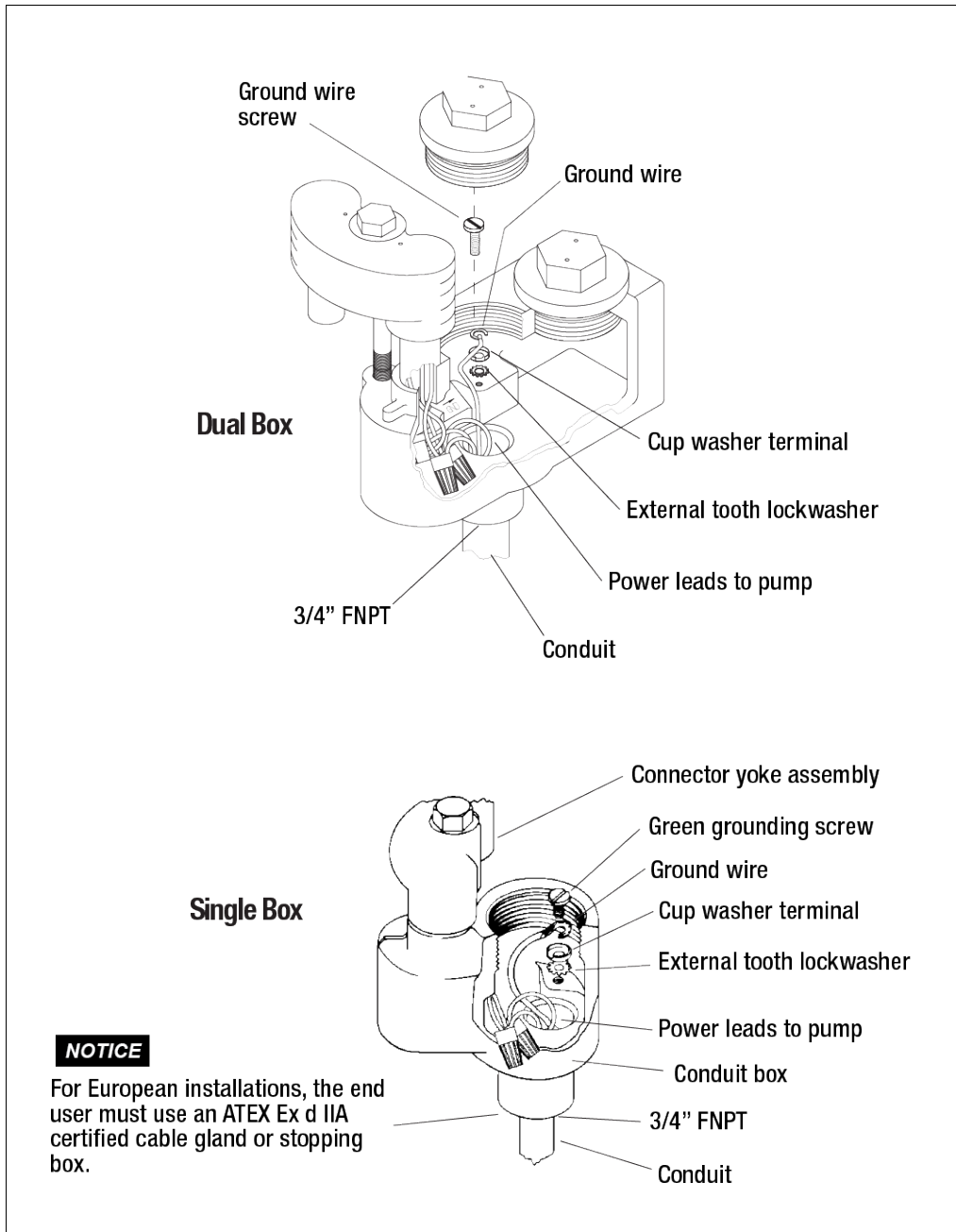

Figure 14. Conduit Box Wiring

Figure 15 through Figure 20 display various wiring diagrams.

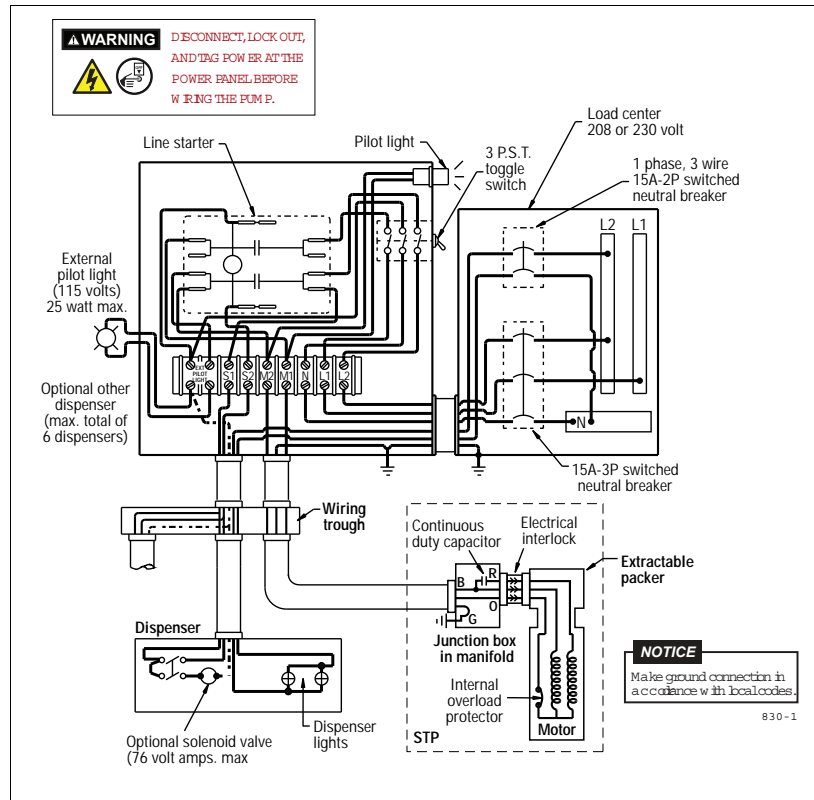

Figure 15. 230 VAC Remote Control Box With 110 VAC Coil - Model 880-041-5

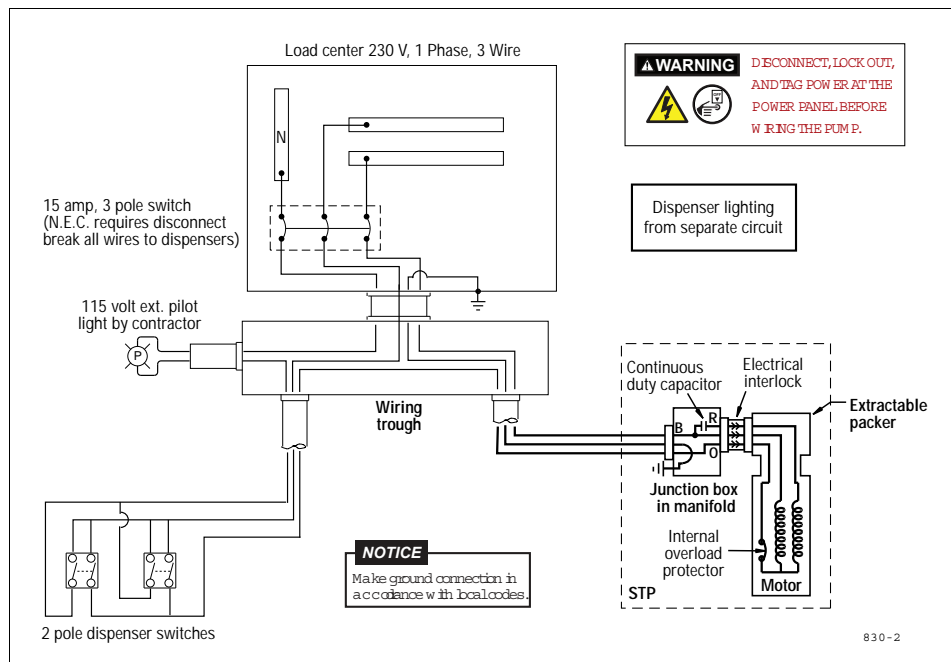

Figure 16. Suggested Wiring Diagram Without Optional Control Box

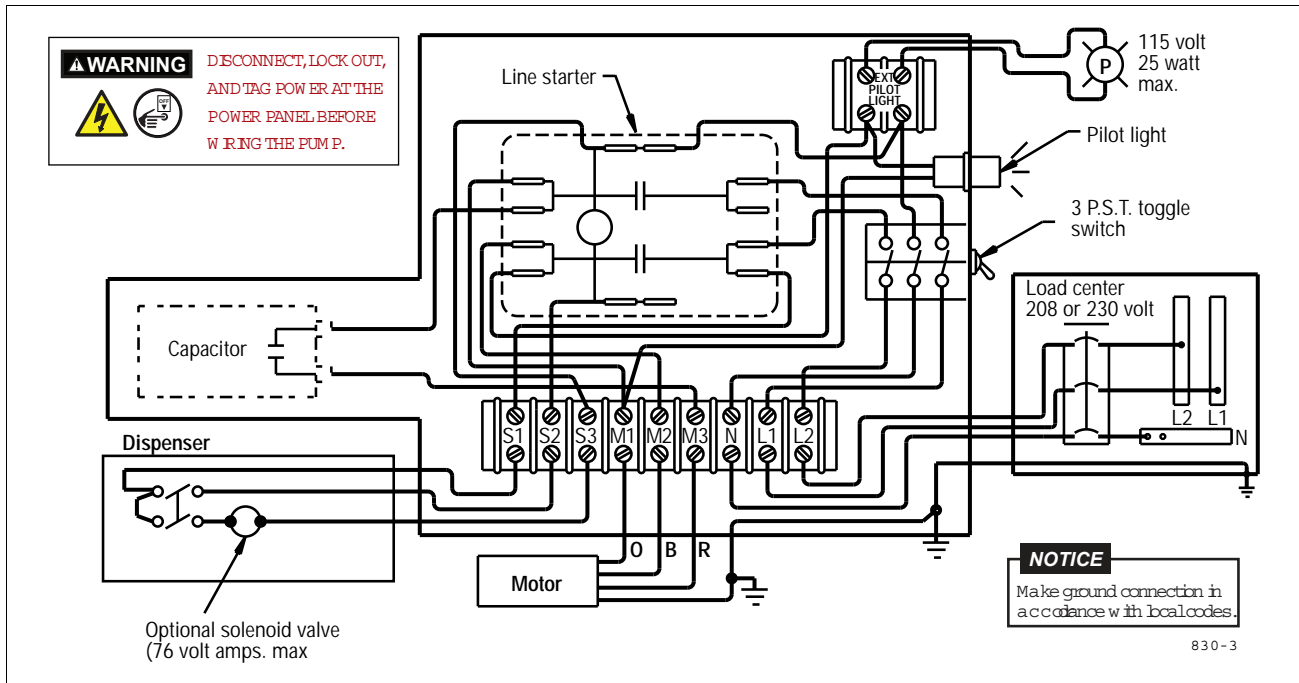

Figure 17. 230 Vac Remote Control Box With 110 VAC Coil And Cap - Model 880-045-5/880-046-5

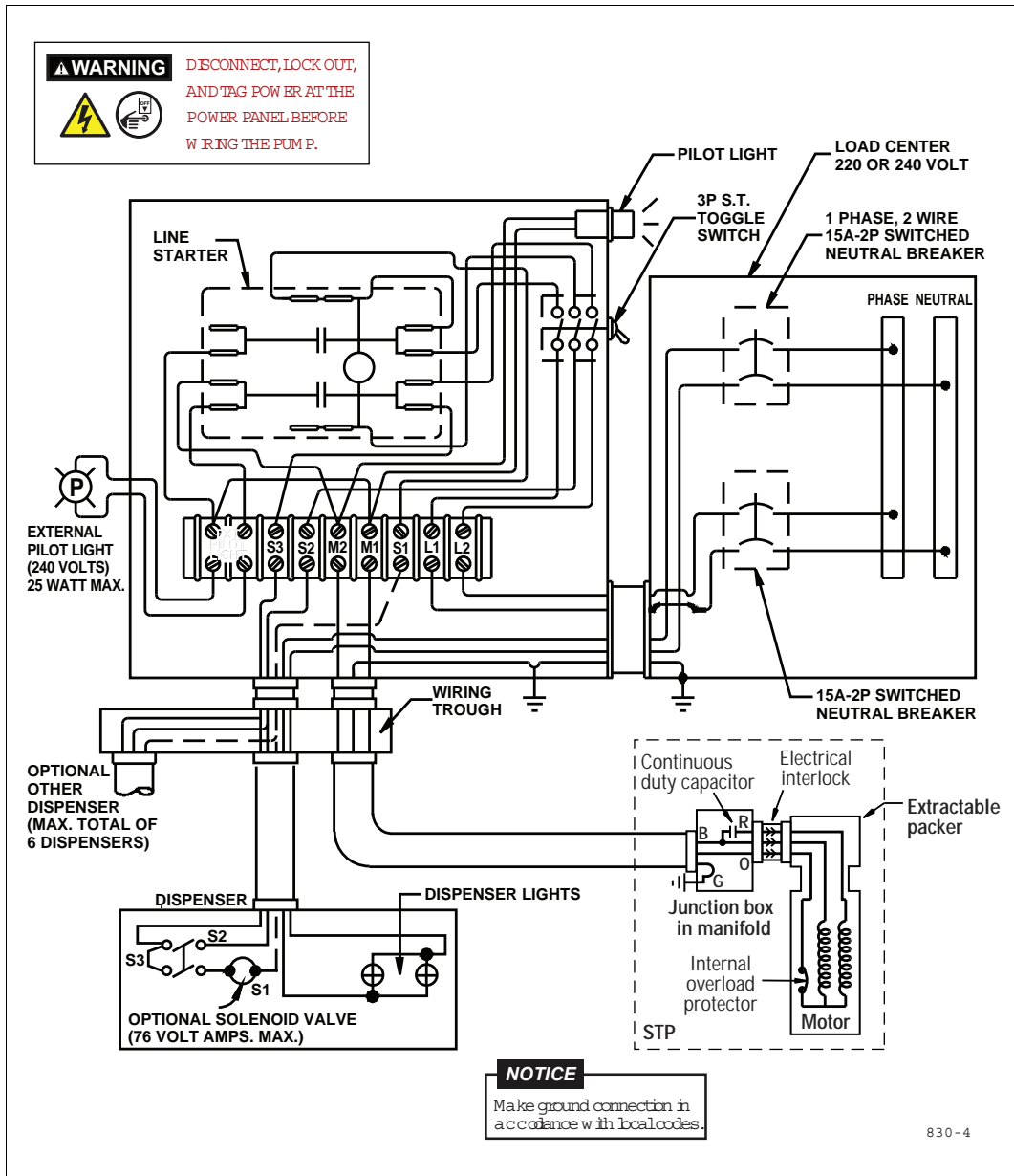

Figure 18. 230 VAC Remote Control Box With 230 VAC Coil - Model 880-042-5

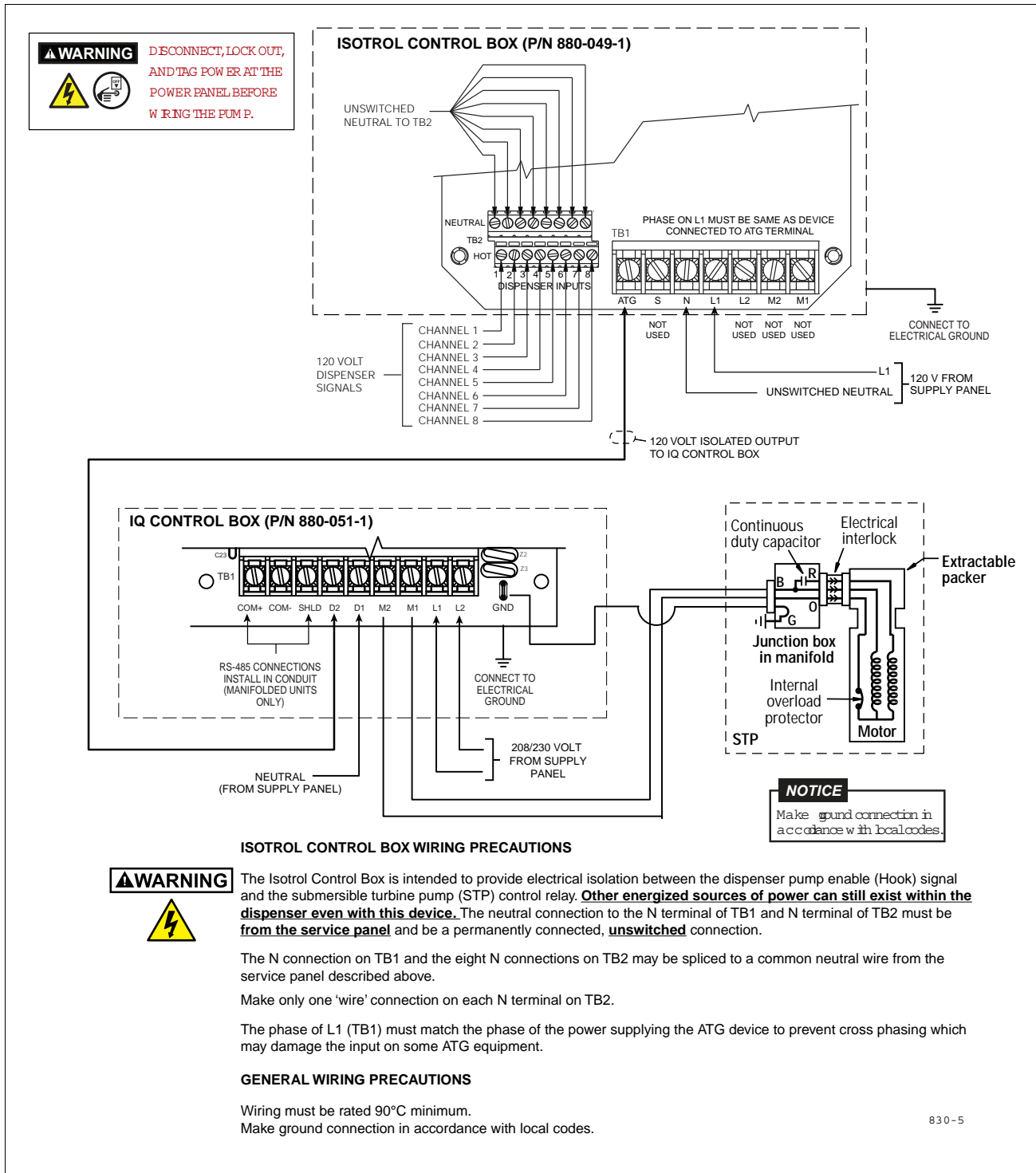
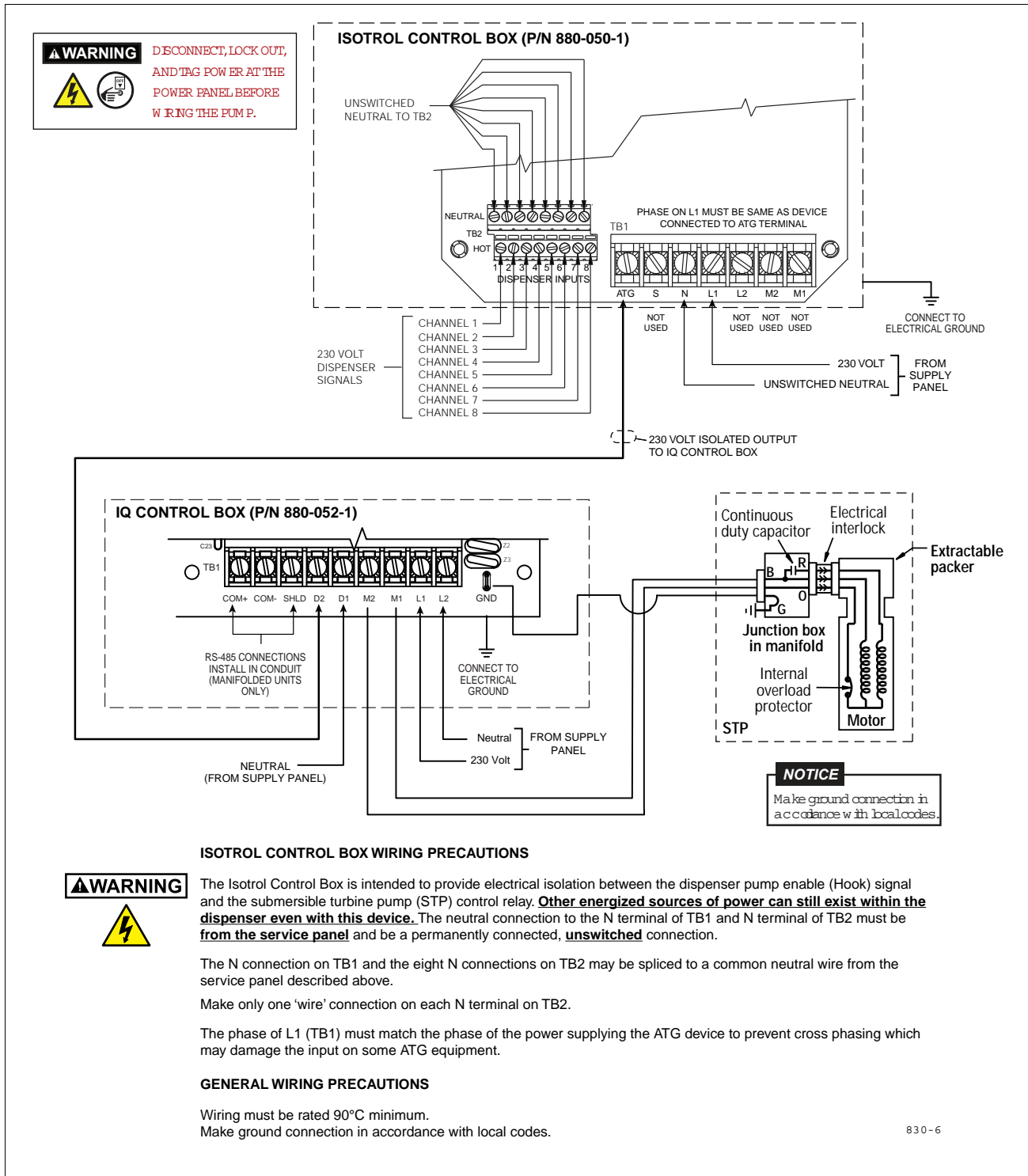

Figure 19. Isotrol To IQ System Wiring - 120 Volt Dispenser Signals



Installing Two Pumps For Tandem Operation

When greater flow rates are needed, two pumps may be installed in the same piping system by means of a manifold. If installed according to the Figure 21, tandem systems offer backup support so operations can continue if one pump stops working.

Alternatively, Veeder-Root's Red Jacket IQ™ Control Unit can be connected to additional control boxes to allow up to four pumps per tank with demand-based sequencing. UMPs containing a Faradyne motor require IQ software 805-001 C (Version 3.2 or newer for proper operation of the system. Refer to specification section.

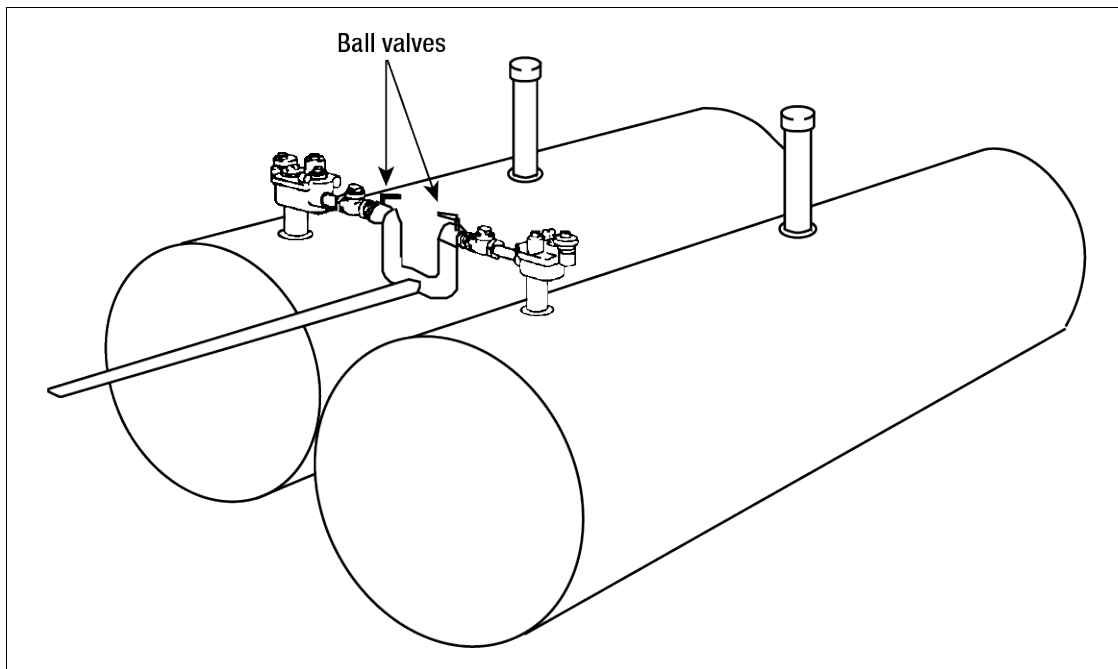

Figure 21. Tandem Pumps

⚠ WARNING Adjust the Functional Element on both packers to maximum relief pressure by rotating fully clockwise. If maximum pump pressures are NOT a minimum of 5 psi (34 kPa) below the Functional Element relief setting then proper check valves with pressure relief are required to be installed in the discharge line of each pump to prevent product from being pumped through the pressure relief system of the adjacent pump when it is not operating.

NOTICE Ball valves should be installed at the pump end of the discharge line for ease of maintenance and troubleshooting (see Figure 21).

NOTICE The in-line check valves and 115 Vac relay are not available from Veeder-Root and should be purchased locally.

Wiring Single-Phase Tandem Pumps

Figure 22 shows the wiring allowing both STPs to operate simultaneously with any combination of dispensers turned on. To operate individually, the appropriate toggle switch, located externally on the side of the control box can be turned off manually.

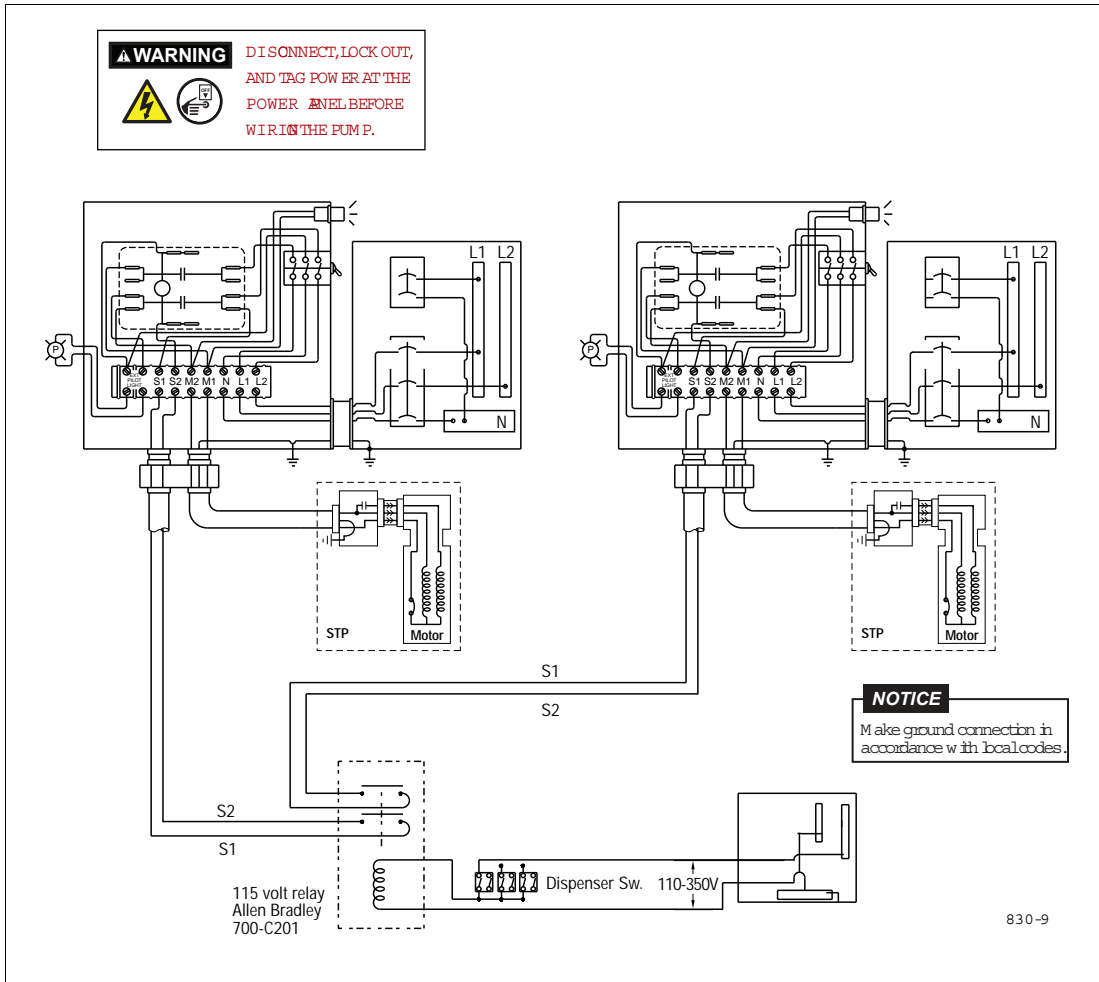

Figure 22. Suggested Wiring For Tandem Pumps

Wiring Three-Phase Tandem Pumps

Figure 23 shows the wiring schematic which allows both three-phase STPs to operate simultaneously with any combination of dispensers turned on.

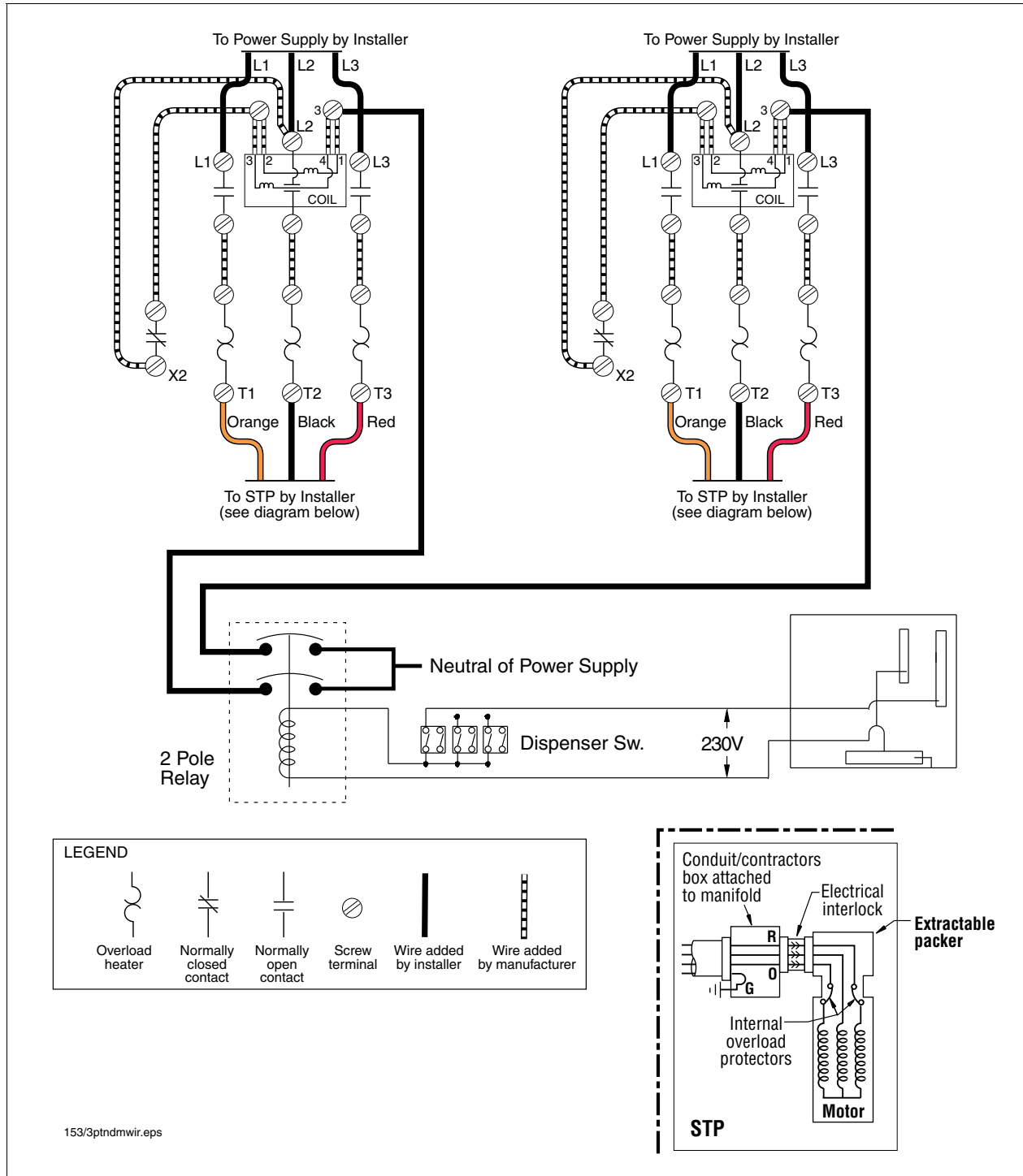

Figure 23. Suggested Wiring For Three-Phase Tandem Pumps

Adjusting The Functional Element

WARNING



Disconnect, lock out, and tag power at the panel before servicing the pump.

The Functional Element contained in this package is an adjustable model. All new Functional Elements are factory set at relief pressures of 11.5 - 16 psi (79 - 93 kPa) but can be adjusted to a maximum of approximately 30 psi (207 kPa) by turning down the adjustment screw.

This adjustment feature allows the use of the Red Jacket Standard pump with electronic line leak detection systems that require higher relief pressures and enhances performance of electronic line leak detection systems where field conditions have necessitated minor adjustments to the relief pressure.

To Adjust the Relief Pressure

1. Remove the cap (see Figure 24).
2. Turn down the adjustment screw (see Figure 24). Tightening the screw clockwise will increase the pressure. When the adjusting screw is fully down, the relief pressure is approximately 30 psi (207 kPa). Fully up will result in relief pressures between 0 - 3 psi (0 - 20 kPa).
3. Lubricate the cap's o-ring with petroleum jelly and replace cap by turning it until it contacts the Functional Element body. Hand tightening is sufficient as the o-ring completes the seal.

There are two methods to verify the relief pressure setting:

- a. The pressure reading can be taken from the control unit of an electronic line leak detection system if one is in operation. Observe the pressure that occurs after the pump turns off - this is the adjusted relief pressure.
- b. Pressure may be observed using a gauge attached at the impact valve or the line test port at the pump. Observe the pressure that occurs after the pump turns off - this the adjusted relief pressure.

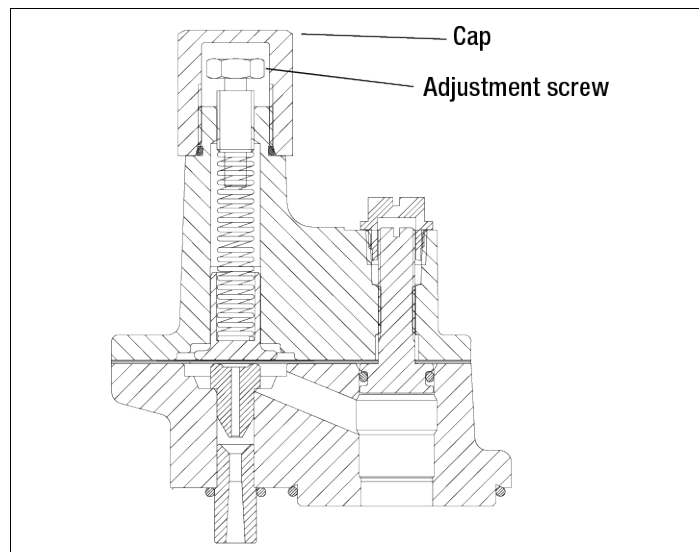

Figure 24. Functional Element Cap And Adjustment Screw

NOTICE When the adjustable Functional Element is installed, the pump/motor unit must operate at a minimum of 5 psi (34 kPa) greater than the relief (seating) pressure at which the Functional Element has been set. An improper pressure setting may cause mechanical damage and will void the warranty.

NOTICE If a siphon system is being utilized, it is especially important to follow the 5 psi (34 kPa) rule, that is the pump must create 5 psi more pressure than the relief pressure setting.

For example, if a relief pressure of 25 psi (170 kPa) is desired, the pump in use must be capable of producing 30 psi (210 kPa).

Table 7. Approximate Pressures at shut-off

Pump	Approximate Shut Off Pressure
AGUMP33R1, UMP33R1	25 psi (172 kPa) .74 SG @ 60°F (15°C)
AGUMP75S1, UMP75S1	28 psi (193 kPa) .74 SG @ 60°F (15°C)
AGUMP150S1, UMP150S1	30 psi (207 kPa) .74 SG @ 60°F (15°C)
X3AGUMP150S1, X3UMP150S1	43 psi (297 kPa) .74 SG @ 60°F (15°C)
AGUMP75S3-3, UMP75S3-3	30 psi (207 kPa) .74 SG @ 60°F (15°C)
AGUMP150S3-3, UMP150S3-3	32 psi (220 kPa) .74 SG @ 60°F (15°C)
X4AGUMP150S3, X4UMP150S3	40 psi (275 kPa) .74 SG @ 60°F (15°C)
AGUMP75S17-3, UMP75S17-3	29 psi (200 kPa) .74 SG @ 60°F (15°C)
AGUMP150S17-3, UMP150S17-3	32 psi (220 kPa) .74 SG @ 60°F (15°C)
X4AGUMP150S17, X4UMP150S17	39 psi (267 kPa) .74 SG @ 60°F (15°C)

Initial Start-Up Of Pump

Turn on the pump and purge the system of air by pumping at least 15 gallons (57 liters) through each dispenser. Begin with the dispenser furthest from the pump and work toward the pump.

Pump start-up is now complete.

NOTE: For Three-Phase Pumps Only!

Where it is not convenient to predetermine the power supply phase rotation, the proper rotation can be determined by pump performance. The pump head pressure and capacity will be considerably less than rated when rotating backwards.

Connect the pump leads to terminals T1, T2, and T3 of the magnetic starter observing the color code shown in Figure 25 A, B, and C. With ample product in the tank and the system purged of air, start the pump and make a pressure gauge reading of the system pressure with the ball valve closed; or, open valve and calculate the pumping rate.

Next, reverse power leads at L1 and L2. Repeat either the pressure or capacity test, as described above. If the results are higher than the first test, the rotation of the second test is correct. If the second test gives lower performance than the first, reconnect the power leads to L1 and L2 (as under test 1) for the correct rotation.

Where the power supply has been properly marked L1, L2, and L3 in accordance with the accepted phase rotation standards, it is possible to predetermine the proper rotation of these units. The pump power leads are color coded orange, black, and red, and if connected through the magnetic starter to L1, L2, and L3 respectively, the UMP will rotate in the correct direction. It is recommended, however, that the performance tests always be made whether or not the power supply has been properly 'phased out'.

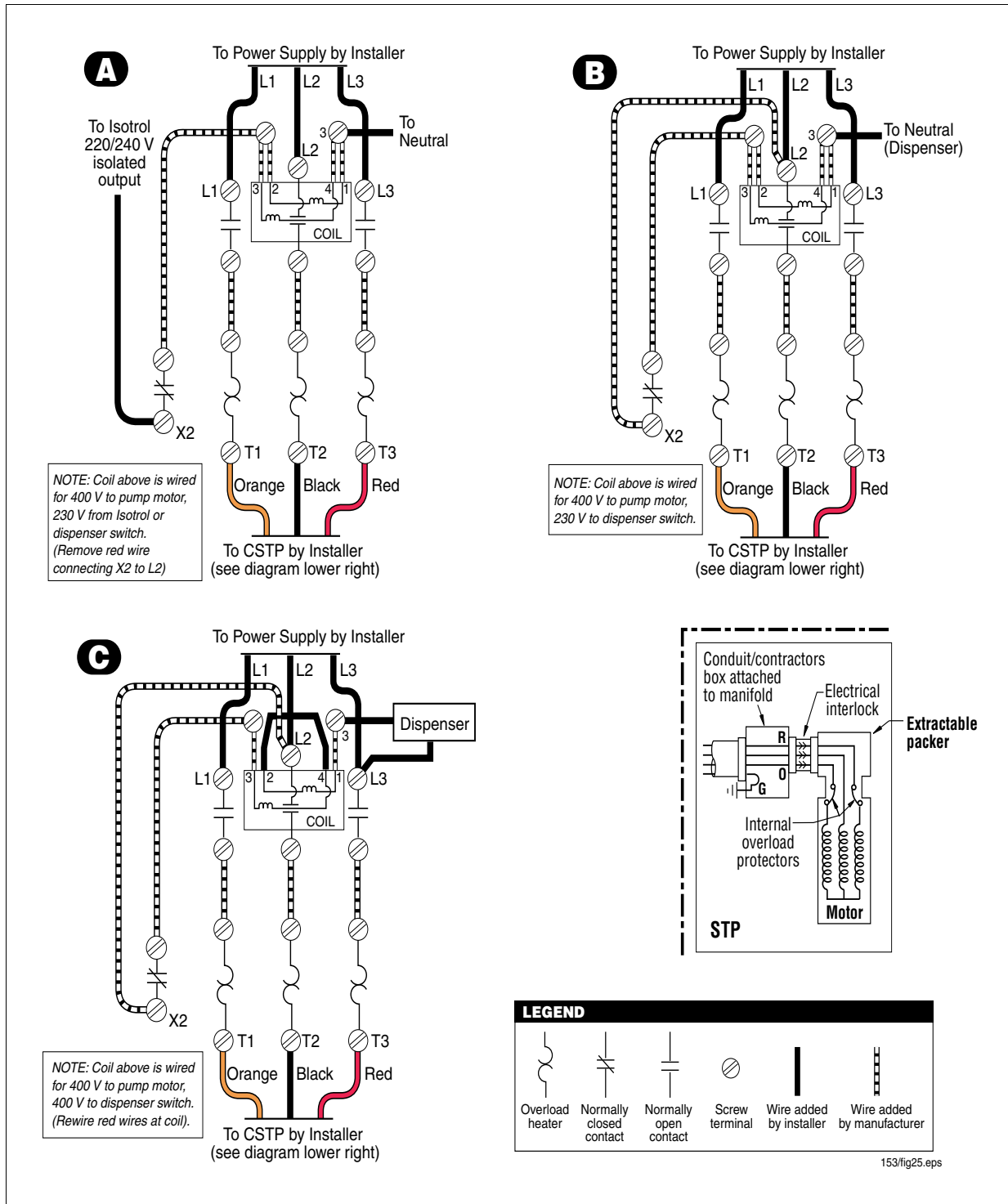

Figure 25. Three-Phase Pump Wiring Diagram Examples

Testing The Installation

WARNING



Disconnect, lock out, and tag power at the panel before servicing the pump.



When servicing unit use non-sparking tools and use caution when removing or installing equipment to avoid generating a spark.

To Test Piping

1. Block lines at each dispenser. (Trip dispenser shear valve.) Remove line test plug for this test.
2. Remove protective plug and close pump check valve by turning the vent closing screw clockwise as far down as possible (see Figure 26).

WARNING

Excessive pressure (above normal test pressure of 50 - 55 psi [345 - 380 kPa]) may damage check valve seat and other system components.

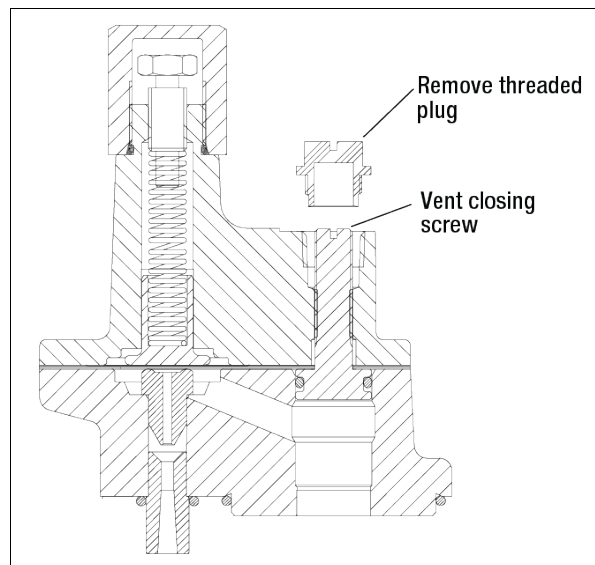

Figure 26. Closing The Check Valve

3. Remove line test port plug and apply line test pressure at line test port (50 psi [345 kPa] maximum) - see Figure 27.
4. Depressurize the line by reversing Step 2. Replace the protective plug over the vent closing screw.
5. Apply adequate amount of fresh, UL classified for petroleum, non-setting thread sealant on the 1/4" NPT line test port plug and replace it. Torque the plug to 14 - 24 ft-lbs (19.4 - 29 N•m)

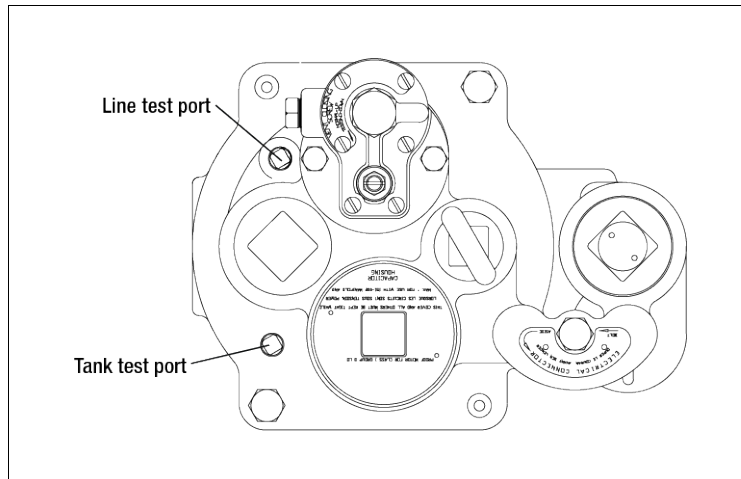

Figure 27. Line Test Port

To Test Tank

WARNING



Disconnect, lock out, and tag power at the panel before servicing the pump.



When servicing unit use non-sparking tools and use caution when removing or installing equipment to avoid generating a spark.

1. Remove the protective plug and close pump check valve by turning the vent closing screw (see Figure 26) as far down as possible. Remove the 1/4" NPT tank test port plug and attach tank testing equipment. Apply tank test pressure at tank test port.
2. After completion of tank tests, depressurize tank and remove testing equipment. Apply an adequate amount of fresh, UL classified for petroleum, non-setting thread sealant on the 1/4" NPT plug and replace it in the tank test port. Torque the plug to 14 to 21 ft-lbs (19.4 to 29 N•m).
3. After the installation is completed and tests have been made, purge system of air by pumping at least 15 gallons (57 liters) through each dispenser. Begin with the dispenser furthest from the pump and work toward the pump.

Service And Repair

Removing the Pump

⚠ WARNING



Disconnect, lock out, and tag power at the panel before servicing the pump.



When servicing unit use non-sparking tools and use caution when removing or installing equipment to avoid generating a spark.

1. If a ball valve is installed down line from the pump, close it.
2. Back out the electrical yoke disconnect bolt (see Figure 28).

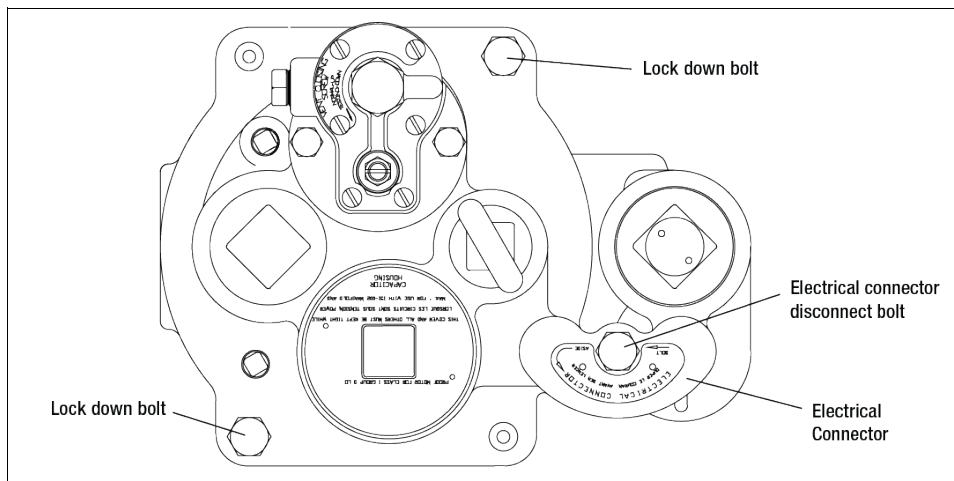

Figure 28. Packer

3. Swing the electrical connector aside.
4. If a siphon system is in place, disconnect the siphon tubing. If ball valves are installed, close them.
5. Remove the two lock-down bolts. To relieve pressure, rock the pump to allow excess pressure to flow into the tank or back out Functional Element screw.

⚠ WARNING

Confirm that the packer wiring compartment cover/plug (with lifting eyebolt) is properly torqued at 50 ft-lbs (70 N•m). Confirm that the lifting eyebolt is properly torqued to 10 ft-lbs (13.6 N•m) with a minimum of 6 full threads installed. Occasionally, eyebolts are removed after pump installation and corrosion may occur in the threaded areas of the wiring compartment cover/plug and the eyebolt. If corrosion has occurred, the cover/plug and eyebolt should be replaced.

6. Utilize the lifting eyebolt to lift out the extractable unit and place it on a clean surface. **Removal of the extractable section of the pump must be conducted with caution.** Make certain that the extractable portion remains centered within the riser pipe and that no portion of the extractable binds during the removal process. If binding occurs during removal, stop and determine the cause of the binding and correct the situation before proceeding with removal.
7. Lift out the extractable unit.

⚠ WARNING

DO NOT damage the surface above the discharge port. The o-ring below the leak detector port seals on this surface.

NOTICE Before replacing the extractable portion, make sure that the packer o-ring and discharge o-ring seal surfaces are clean. New o-rings should be installed, lubricate with petroleum jelly.

Replacing the UMP

WARNING



Disconnect, lock out, and tag power at the panel before servicing the pump.



When servicing unit use non-sparking tools and use caution when removing or installing equipment to avoid generating a spark.

1. Remove the extractable portion of the old pump from the tank as described in Removing the Pump.
2. Remove the old UMP by removing the four bolts holding the discharge head as shown in Figure 29.

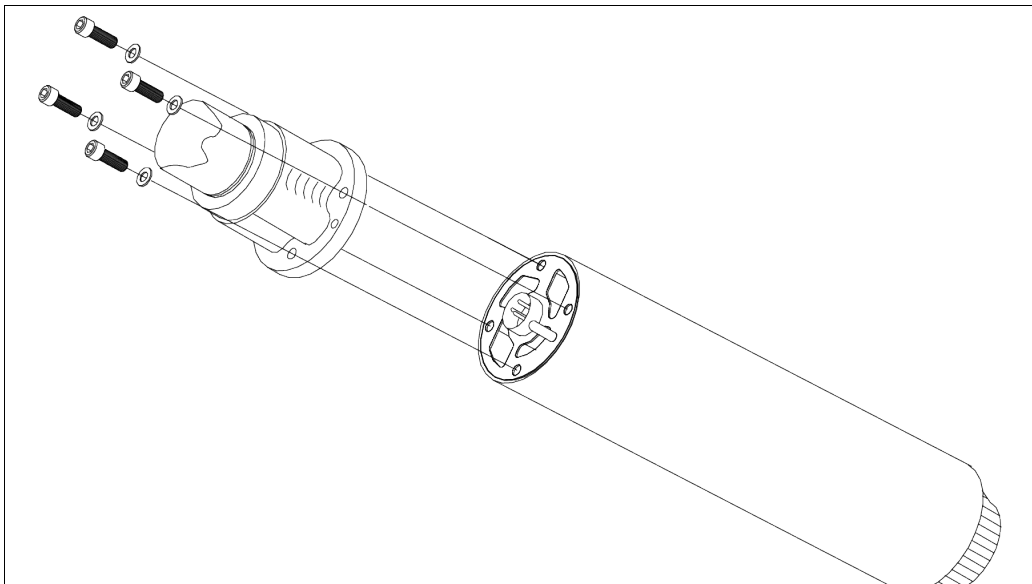

Figure 29. Removing The UMP

3. Rock the unit while pulling away from the discharge head until it is free.
4. Replace the old gasket with a new one provided. Place the new gasket on the new UMP so that all the holes align (see Figure 30).

CAUTION

Gaskets from competitive UMPs will not seal properly and performance will be reduced.

5. Visually inspect the pigtail connector in the discharge head - replace if damaged. Be certain the indexing tab of the pigtail is seated in the notch of the discharge head.

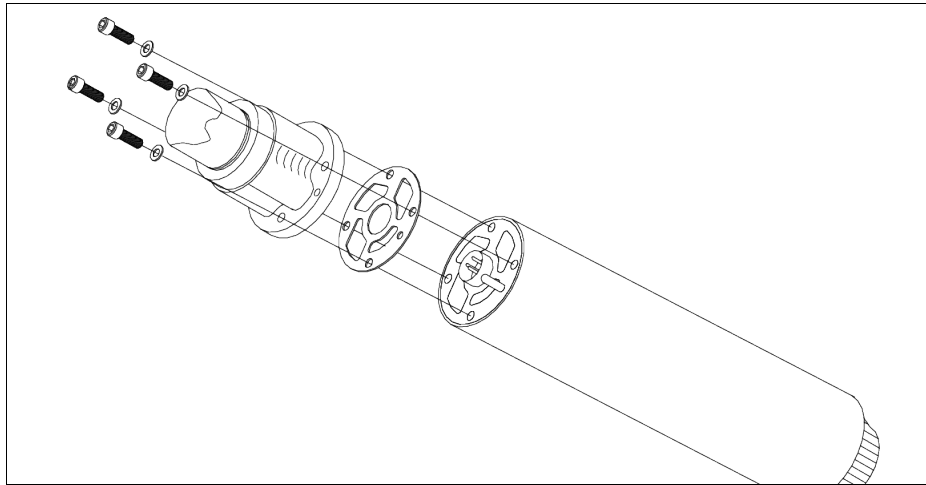

Figure 30. Replacing The gasket

6. Pull the pigtail connector in the discharge head out far enough to see the o-ring in the sidewall of its socket (see Figure 31). Remove the connector's o-ring from the connector's socket and discard it. Get a 0.551" ID x 0.070" wide o-ring from the kit and lubricate it with petroleum jelly. Slide the new o-ring over the pigtail connector and push it in the groove in the wall of the connector's socket. Lubricate the pigtail connector body with petroleum jelly and push it back into its socket, making sure its index tab is in the socket's notch.

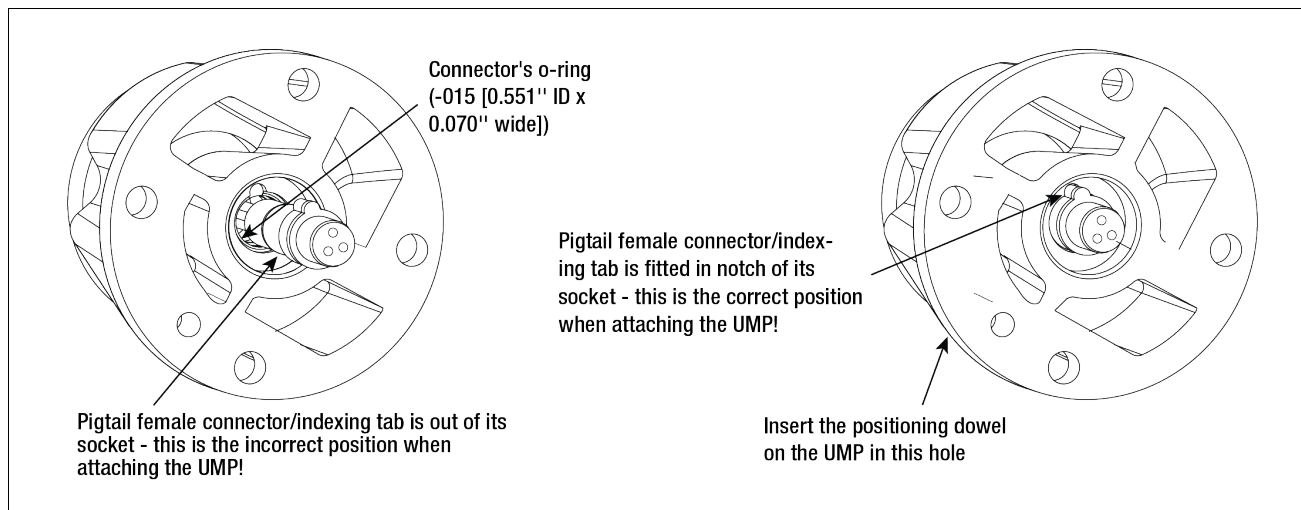

Figure 31. Verifying Pigtail's Female Connector Is Seated Properly

7. Lubricate o-ring and pigtail with petroleum jelly.
8. Align the UMP positioning dowel and boss with the proper holes in the discharge head and push the UMP into position using hand force only. The UMP should be snug against the discharge head prior to installing the UMP retaining bolts.

⚠ WARNING Use hand force to put the UMP onto the discharge head. If the UMP does not seat properly, snug against the discharge head, remove the UMP and correct the problem.

9. Install the four UMP retaining bolts and lock washers. Snug and then torque the bolts using a cross pattern technique. Torque to 7 ft-lb (11 N•m).

⚠ WARNING Do not over torque the bolts. Not following these instructions may cause parts to fail.

10. Replace the packer o-ring and the discharge o-ring seals after lubricating them with petroleum jelly.
11. Reinstall the extractable portion into the tank using the steps previously described under "Installing The Pump" on page 15.

NOTICE Before replacing the extractable, make sure that the surfaces of the packer o-ring and the discharge o-ring seals are clean.

12. Refer to section entitled "Testing The Installation" on page 31.
13. If applicable, open the ball valve down line from the pump.

Replacing The Quad Seal

⚠ WARNING



Disconnect, lock out, and tag power at the panel before servicing the pump.



When servicing unit use non-sparking tools and use caution when removing or installing equipment to avoid generating a spark.

1. If a ball valve is installed down line from the pump, close it.
2. If an electronic line leak detection transducer is installed, it must be removed from the leak detector port following instructions in the appropriate Line Leak installation manual (see Figure 32). A mechanical line leak detector does not need to be removed.

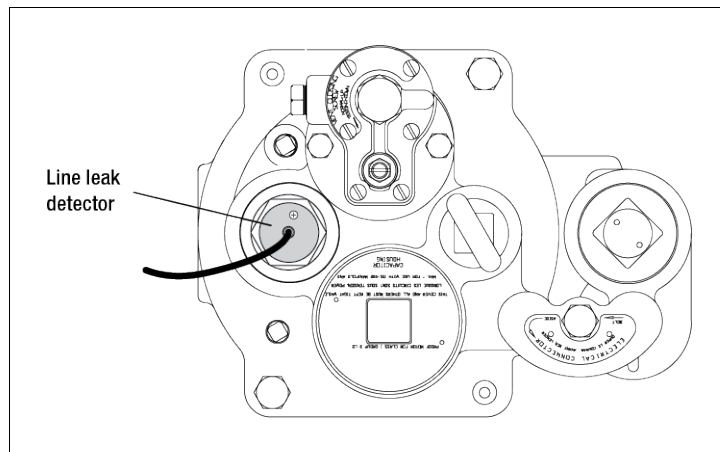

Figure 32. Electronic Line Leak Detector

3. Back out the electrical yoke disconnect bolt (see Figure 28 on page 33).
4. Swing the electrical connector aside.
5. If a siphon system is in place, disconnect the siphon tubing. If ball valves are installed, close them.
6. Remove the two lock-down bolts. To relieve pressure, rock the pump to allow excess pressure to flow into the tank or back out pressure adjustment screw (see Figure 24 on page 28).

⚠ WARNING

Confirm that the packer wiring compartment cover/plug (with lifting eye bolt) is properly torqued at 50 ft-lbs (70 N•m). Confirm that the lifting eye bolt is properly torqued to 10 ft-lbs (13.6 N•m) with a minimum of 6 full threads installed. Occasionally, eye bolts are removed after pump installation and corrosion may occur in the threaded areas of the wiring compartment cover/plug and the eye bolt. If corrosion has occurred, the cover/plug and eye bolt should be replaced.

7. Utilize the lifting eye bolt to lift out the extractable unit and place it on a clean surface. Removal of the extractable section of the pump must be conducted with caution. Make certain that the extractable portion remains centered within the riser pipe and that no portion of the extractable binds during the removal process. If binding occurs during removal, stop and determine the cause of the binding and correct the situation before proceeding with removal.
8. Lift out the extractable unit.

⚠ WARNING

DO NOT damage the surface above the manifold's discharge port. The quad seal below the packer's leak detector port seals on this surface.

9. Once the pump is lifted off of the manifold, remove the old quad seal from the base of the packer (under the line leak port (see Figure 33).
10. Clean the seating surface and the sealing surface of the quad seal.
11. Lubricate the quad seal with petroleum jelly and install it into the base of the packer's line leak port. The seal's retaining lip fits over the outward angled edge of the port as shown in Figure 34.

⚠ WARNING Proper replacement of the quad seal is critical for maintenance of product line pressure. An improper seal will allow the release of product inside the unit and back into the tank.

12. Lubricate the 7" packer o-ring with petroleum jelly and install it in the groove in the packer (see Figure 33).

⚠ WARNING For fixed length pumps: Confirm that the lifting eyebolt is properly torqued to 10 ft-lbs (13.6 N•m) with a minimum of 6 full threads installed. Occasionally, eyebolts are removed after pump installation and corrosion may occur in the threaded areas of the wiring compartment cover (eyebolt plug) and the eyebolt. If corrosion has occurred, the cover and eyebolt should be replaced.

13. Utilize the lifting eye bolt to suspend the pump vertically and then install the pump into the manifold.

NOTICE Before replacing the extractable, make sure that the surfaces of the packer o-ring and the quad seal are clean.

14. Install the pump into the manifold.
15. Align the positioning dowels of the manifold with the holes in the packer.
16. Push the packer as far as possible against the manifold.
17. Insert the lock-down bolts and torque to 45 – 55 ft-lb (61 – 75 N•m).
18. Loosen the bolts that hold the conduit box to the manifold. Do not remove.
19. Swing the electrical connector into position.
20. Torque the electrical connector bolt to 25 – 50 ft-lb (34 – 68 N•m).
21. Torque the conduit box bolts to 30 – 45 ft-lb (40 – 61 N•m).

NOTICE Suggested tools (non-sparking) include a 3/4" wrench, pipe wrench, 1/4" Allen wrench, 9/16" wrench, screw driver, wire cutter and wire stripper.

22. If applicable, open ball valve down line from the pump.
23. After the installation is completed and tests have been made, purge system of air by pumping at least 15 gallons (57 liters) through each dispenser. Begin with the dispenser furthest from the pump and work toward the pump.

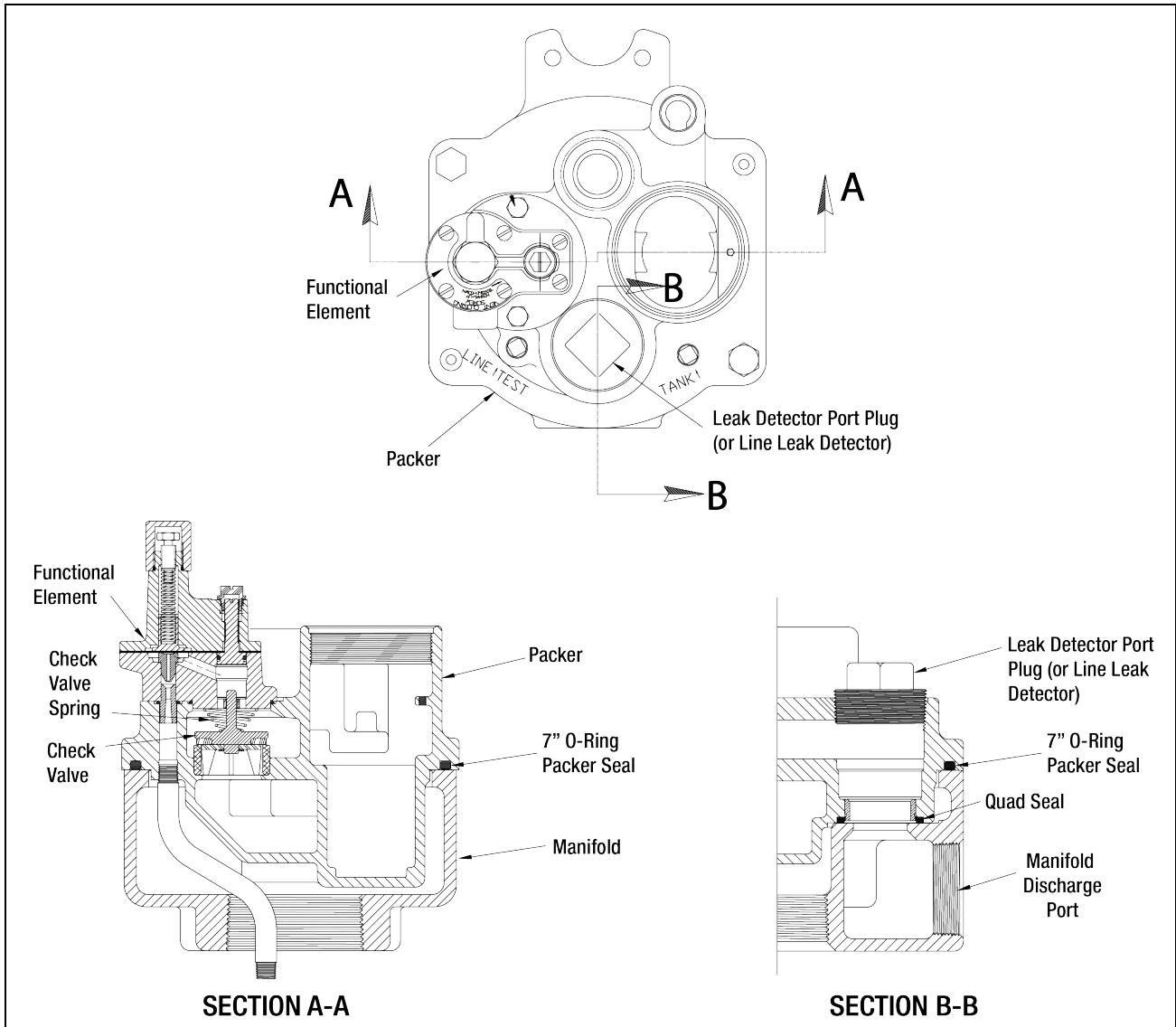

Figure 33. Locating 7" Packer O-Ring And Quad Seal

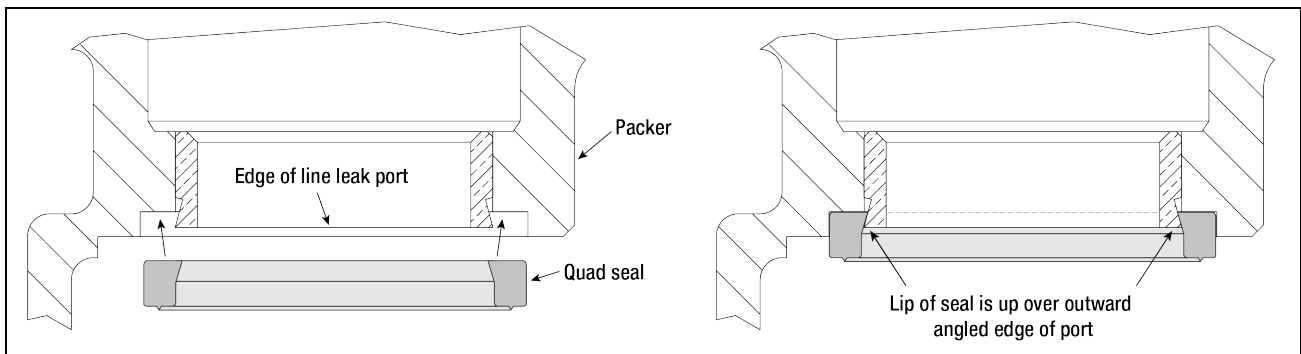

Figure 34. Installing New Quad Seal

Replacing The Check Valve, Spring And Functional Element



Disconnect, lock out, and tag power at the panel before servicing the pump.



When servicing unit use non-sparking tools and use caution when removing or installing equipment to avoid generating a spark.

Disable the Pump

1. If a ball valve is installed down line from the pump, close it.
2. Back out the electrical connector disconnect bolt (see Figure 35).

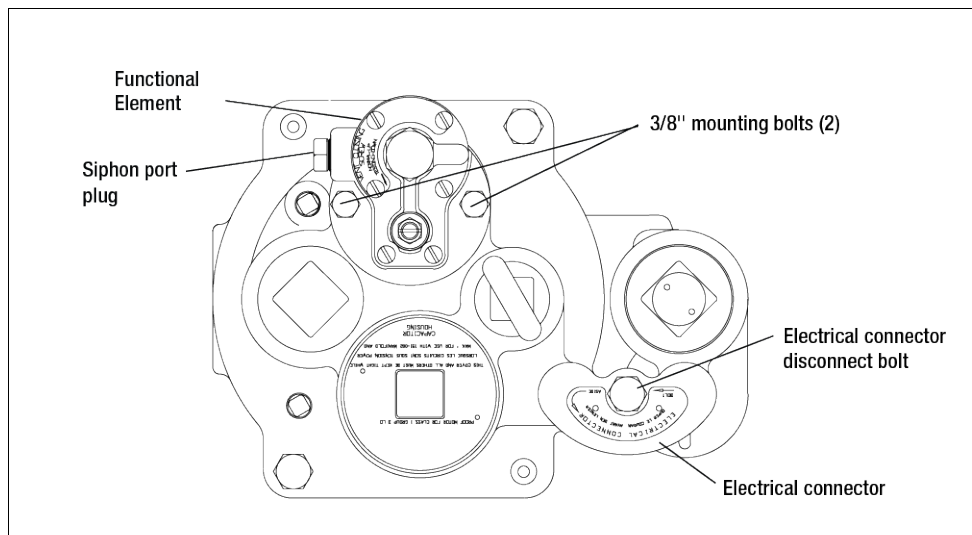

Figure 35. Packer With Functional Element

3. Swing the electrical connector aside.
4. To relieve the pressure, back out Functional Element screw (see Figure 24 on page 28), or remove the two lock-down bolts and rock the pump to allow excess pressure to flow into the tank.

Replace the Check Valve, Spring and Functional Element

1. If siphon tubing is connected to the functional element, disconnect the siphon fitting from the old functional element (see Figure 35).
2. Remove and discard the two 3/8 inch bolts securing the functional element to the packer.
3. Carefully lift the functional element assembly from the packer. Notice the spring resting on the check valve inside the packer. The larger diameter end of the spring is facing up. Notice the small O-ring (0.379" O.D.) in the groove around the diaphragm vent port in the mating surface of the packer (see Figure 36).
4. Remove and discard the old spring and old check valve. Remove and discard the small O-ring in the groove around the packer's diaphragm vent port.
5. Be certain all mating surfaces are clean. Lubricate the three new functional element O-rings from the kit with petroleum jelly. Install the 2.193" O.D. and 0.63" O.D. O-rings in the bottom of the functional element as shown in Figure 36. Install the new 0.379" O.D. O-ring in the groove around the packer's diaphragm vent port.

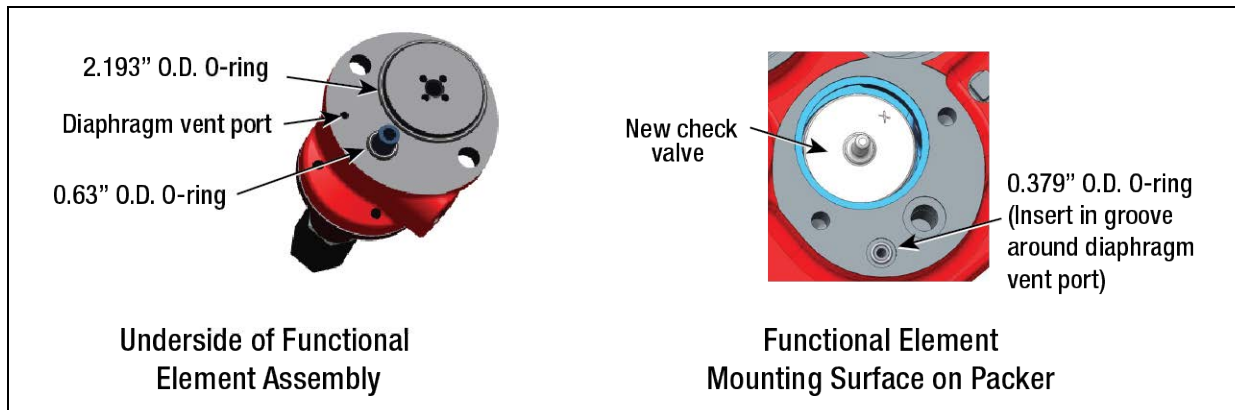

Figure 36. Functional Element O-Rings

6. Position the new check valve in the packer in same position as was the old check valve (see Figure 36). Position the new check valve spring on top of the new check valve with the larger diameter end of the spring facing up.
7. Carefully set the new functional element assembly in place, then install the two new 3/8-inch securing bolts from the kit and torque to 20 - 35 ft-lb (27 - 50 N•m).
8. If siphon tubing is installed, remove the siphon plug from the new functional element. Connect the siphon tubing fitting to the siphon port using fresh, UL classified for petroleum, non-setting thread sealant.
9. If applicable, open ball valve down line from the pump.

Replacing the Capacitor in Packer

WARNING



Disconnect, lock out, and tag power at the panel before servicing the pump.



When servicing unit use non-sparking tools and use caution when removing or installing equipment to avoid generating a spark.

WARNING

Serious injury or death can result from using a generic-type capacitor. Generic-type capacitors do not contain internal bleed resistors.

NOTICE Capacitor for 1/3 and 3/4 HP models is 440V, 17.5 μ F continuous duty with internal bleed resistor. Capacitor for 1-1/2 HP models is 440V, 25 μ F continuous duty with internal bleed resistor.

1. Remove wiring compartment cover.
2. Remove retaining clip.
3. Pull out capacitor.
4. Pull quick connectors.
5. Push connectors onto new capacitor.
6. Push capacitor into wiring compartment. Clip into place.
7. Lubricate capacitor cover O-ring with petroleum jelly and reinstall cover. Do not use thread sealant. Torque to 35 ft-lb (50 N•m).

Installing a Replacement Extractable Pump

⚠ WARNING



Disconnect, lock out, and tag power at the panel before servicing the pump.



When servicing unit use non-sparking tools and use caution when removing or installing equipment to avoid generating a spark.

IF FIXED LENGTH, SKIP TO STEP 9.

1. If a ball valve is installed down line from the pump, close it.
2. Remove existing Red Jacket pump - see "Removing the Pump" on page 33.

NOTICE Confirm length of pump prior to installation.

⚠ WARNING

Do not damage the surface above the discharge port. The o-ring below the leak detector port seals on this surface.

3. Attach the UMP (see "Attaching The UMP" on page 13).
4. Measure the distance from the bottom of the tank to the sealing surface on the manifold.
5. Uncoil pigtail and lay flat so it will feed into the packer without knotting or kinking.
6. Loosen the clinch assembly starting by unscrewing the set screw in the side of locking nut, then backing off the locking nut (see Figure 10 on page 16).

NOTICE A slight twisting of the UMP will loosen the seals and facilitate adjusting it to the correct length. Do not rotate piping beyond 1/4 turn.

7. Pull the UMP end until the distance between the packer o-ring seal and the bottom of the UMP is 5 inches (125 mm) (14 inches [356 mm] for floating suction) shorter than the distance measured in Step 4.

NOTICE If UMP is equipped with floating suction adapter, see "Recommended Floating Suction Installation" on page 6.

⚠ WARNING

Take care not to damage the pigtail. If pump is to be adjusted shorter, keep tension on the pigtail to eliminate kinking.

8. Tighten the column pipe locking nut and torque to 150 ft-lb (200 N•m), then torque the set screw to 30 - 35 in-lb (3.5 - 4 N•m).
9. Attach tubing to barbed fitting, secure with clamp.

NOTICE Return line should be installed on every application to reduce nuisance trips of electronic tank monitoring.

10. Lay the siphon return line tubing beside the column pipe. Stop 1 - 3 inches (25 - 76 mm) above the discharge head.
11. Secure the siphon return line tubing to the column pipe with tie straps. Locate the tie straps approximately 6 inches (152 mm) from packer, 6 inches from the discharge head, and in the middle of the tubing.

⚠ WARNING

For fixed length pumps: If removed, install eyebolt plug, using an adequate amount of fresh, UL classified for petroleum, non-setting thread sealant and torque to 50 ft-lbs (70 N•m). Confirm that the lifting eyebolt is properly torqued to 10 ft-lbs (13.6 N•m) with a minimum of 6 full threads installed. Occasionally, eyebolts are removed

after pump installation and corrosion may occur in the threaded areas of the wiring compartment cover (eyebolt plug) and the eyebolt. If corrosion has occurred, the cover and eyebolt should be replaced.

12. Utilize the lifting eyebolt to suspend the pump vertically and then install the pump into the manifold per Step 18.
13. Remove cover from wiring compartment.
14. Pull pigtail wires into wiring compartment.
15. Cut pigtail wires leaving approximately 8 inches (200 mm) hanging out of wiring compartment.
16. Strip insulation off all wires 3/8 inch (10 mm).
17. Using supplied wire nuts attach like colored pump pigtail wires to like colored electrical connector wires as shown in Figure 37.

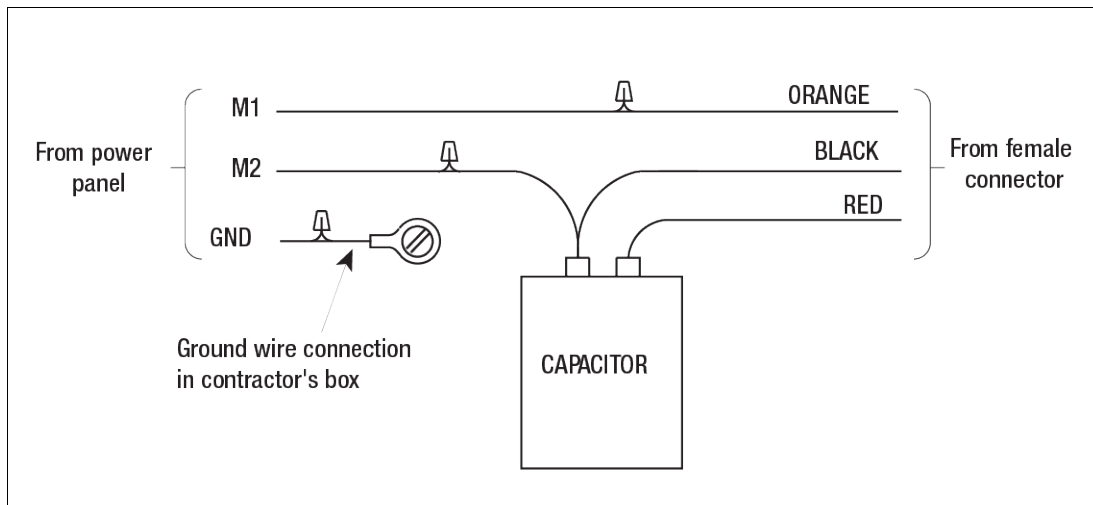

Figure 37. Wiring Schematic

18. Install excess wire into wiring compartment. Replace wiring compartment cover. Torque to 35 ft-lb (50 N•m). Thread sealant should not be used.
19. Install the pump into the manifold.

⚠ WARNING

For fixed length pumps:

If removed, install eyebolt plug, using an adequate amount of fresh, UL classified for petroleum, non-setting thread sealant and torque to 50 ft-lbs (70 N•m). Confirm that the lifting eyebolt is properly torqued to 10 ft-lbs (13.6 N•m) with a minimum of 6 full threads installed. Occasionally, eyebolts are removed after pump installation and corrosion may occur in the threaded areas of the wiring compartment cover (eyebolt plug) and the eyebolt. If corrosion has occurred, the cover and eyebolt should be replaced.

20. Utilize the lifting eyebolt to suspend the pump vertically and then install the pump into the manifold.

NOTICE

Before replacing the extractable, make sure that the surfaces of the packer o-ring and the discharge o-ring seals are clean.

21. Align the positioning dowels of the manifold with the holes in the packer.
22. Push the packer as far as possible against the manifold.

23. Insert the lock-down bolts and torque to 45 - 55 ft-lb (61 - 75 N•m).
24. Loosen the bolts that hold the conduit box to the manifold. Do not remove.
25. Swing the electrical connector into position.
26. Torque the electrical connector bolt to 25 - 50 ft-lb (34 - 68 N•m).
27. Torque the conduit box bolts to 30 - 45 ft-lb (40 - 61 N•m).

NOTICE Suggested tools (non-sparking) include a 3/4" wrench, pipe wrench, 1/4" allen wrench, 9/16" wrench, screw driver, wire cutter and wire stripper.

28. If applicable, open ball valve down line from the pump.
29. After the installation is completed and tests have been made, purge system of air by pumping at least 15 gallons (57 liters) through each dispenser. Begin with the dispenser furthest from the pump and work toward the pump.

Parts Lists

Customer Service Number

After unpacking the equipment, please inspect the parts. Make sure all accessories are included and that no damage occurred during shipping. Report any damage to the shipper immediately and inform a customer service representative at 1-800-873-3313 of any equipment damage or missing parts.

Yoke Assembly and Conduit Box Parts

Table 8. Yoke Assembly and Conduit Box Parts List

Item (ref. Figure 38)	Part No.	Description	Qty.
1	113-105-5	Connector - Male (2-wire)	1
1	113-555-5	Connector - Male (3-wire) (Not Shown)	1
2	072-492-1	Ring - Snap	1
3	313-015-5	Connector - Repair (2-wire) AG	1
3	313-021-5	Connector - Repair (3-wire) AG (Not Shown)	1
3	313-002-5	Connector - Repair (2-wire) Petro (Not Shown)	1
3	313-019-5	Connector - Repair (3-wire) Petro (Not Shown)	1
4	108-496-5	Conduit Box - Single Petro	1
4	108-549-5	Conduit Box - Single AG	1

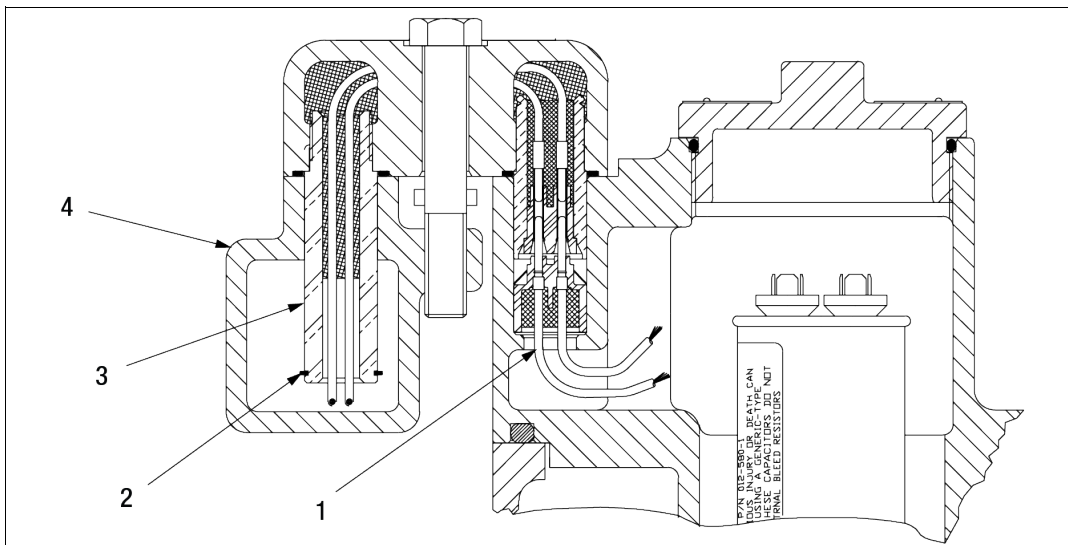

Figure 38. Yoke Assembly And Conduit Box Part Identification

Packer-Manifold Assembly Parts

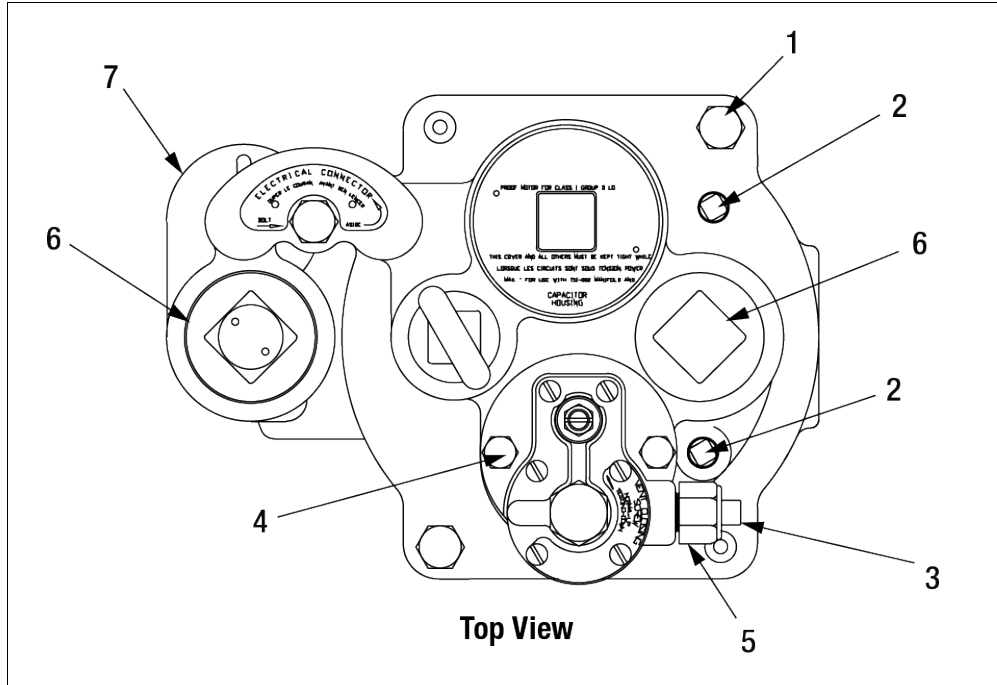

Figure 39. Packer-Manifold Assembly Top View - Part Identification

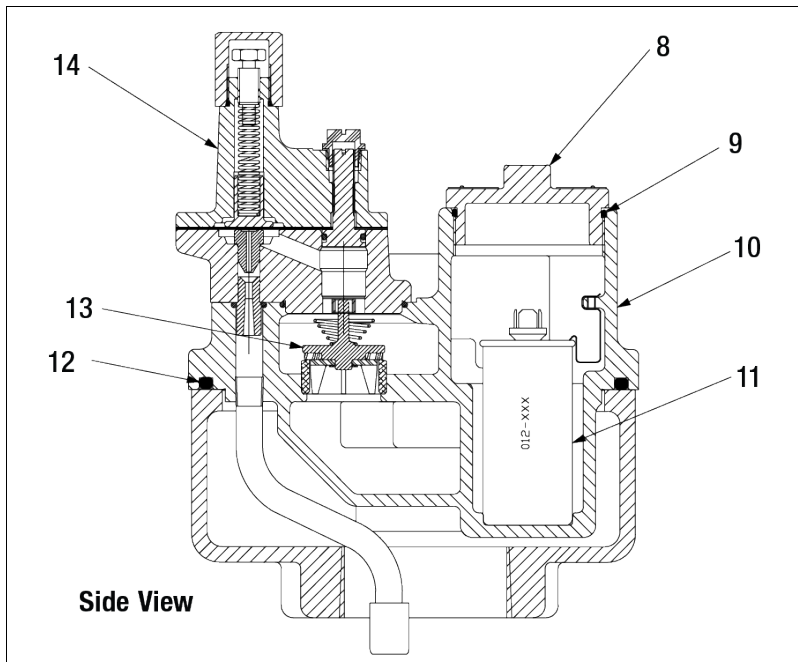

Figure 40. Packer-Manifold Assembly Side View- Part Identification

Table 9. Packer-Manifold Assembly Parts List

Item (Ref. Figure 39 & Figure 40)	Part No.	Description	DOM	INT'L
1	026-205-1	Screw - 1/2-13 x 1-1/4 UNC	2	2
2	027-031-1	Plug - Pipe 1/4" NPT	2	2
3	027-084-1	Plug - Pipe 3/8" NPT	1	1
4	026-176-1	Screw - 3/8-16 x 3/4 UNC	2	2
5	188-241-5	Siphon Check Valve AG	1	1
6	027-086-3	Plug - Pipe 2" NPT (Single Box Only)	1	1
6	067-281-5	Plug - Ass'y. Conduit Box (Dual Box Option Not Shown)	2	2
7	144-229-5	Kit - 2 Wire Electrical Connector & Dual Conduit Box Petro (Not Shown)	1	1
7	144-221-5	Kit - 3 Wire Electrical Connector & Dual Conduit Box Petro (Not Shown)	1	1
7	144-222-5	Kit - 3 Wire Electrical Connector & Dual Conduit Box AG (Not Shown)	1	---
8	113-084-5	P33R1 Capacitor Cover With O-ring	1	---
8	113-085-5	P75S1 Capacitor Cover With O-ring	1	---
8	113-319-5	P150S1 Capacitor Cover With O-ring	1	---
8	113-536-5	X3P150S1 Capacitor Cover With O-ring	1	---
8	113-543-5	X4P150S3 Capacitor Cover With O-ring	---	1
8	113-320-5	P150S3-3 Capacitor Cover With O-ring	---	1
8	113-479-5	AGP33R1 Capacitor Cover With O-ring	1	---
8	113-480-5	AGP75S1 Capacitor Cover With O-ring	1	---
8	113-481-5	AGP150S1 Capacitor Cover With O-ring	1	---
8	113-538-5	X3AGP150S1 Capacitor Cover With O-ring	1	---
8	113-544-5	P75S17-3 Capacitor Cover With O-ring	---	1
8	113-545-5	P150S17-3 Capacitor Cover With O-ring	---	1
8	113-546-5	X4P150S17 Capacitor Cover With O-ring	---	1
8	113-599-5	AGP75S3-3 Capacitor Cover With O-ring	---	1
8	113-600-5	AGP150S3-3 Capacitor Cover With O-ring	---	1
9	072-190-1	Capacitor Cover O-ring Buna (-233) PETRO	1	1
9	072-543-1	Capacitor Cover O-ring FKM (-233) AG	1	1
10	264-138-5	2-Wire Replacement Packer Ass'y. PETRO	1	1
10	264-142-5	2-Wire Replacement Packer Ass'y. AG	1	1
10	264-141-5	3-Wire Replacement Packer Ass'y. PETRO	1	1
11	111-092-5	Capacitor 17.5 μ F	1	1
11	111-661-5	Capacitor 25 μ F	1	1

Table 9. Packer-Manifold Assembly Parts List

Item (Ref. Figure 39 & Figure 40)	Part No.	Description	DOM	INT'L
12	072-718-1	O-Ring - FKM (-443) PETRO	1	1
	072-542-1	O-Ring - FKM (-443) AG	1	1
13	144-183-5	Kit - Check Valve & Spring PETRO	1	1
13	144-184-5	Kit - Check Valve & Spring AG	1	1
14	323-001-5	Functional Element Ass'y. PETRO	1	1
14	323-002-5	Functional Element Ass'y. AG	1	1

Pump Parts

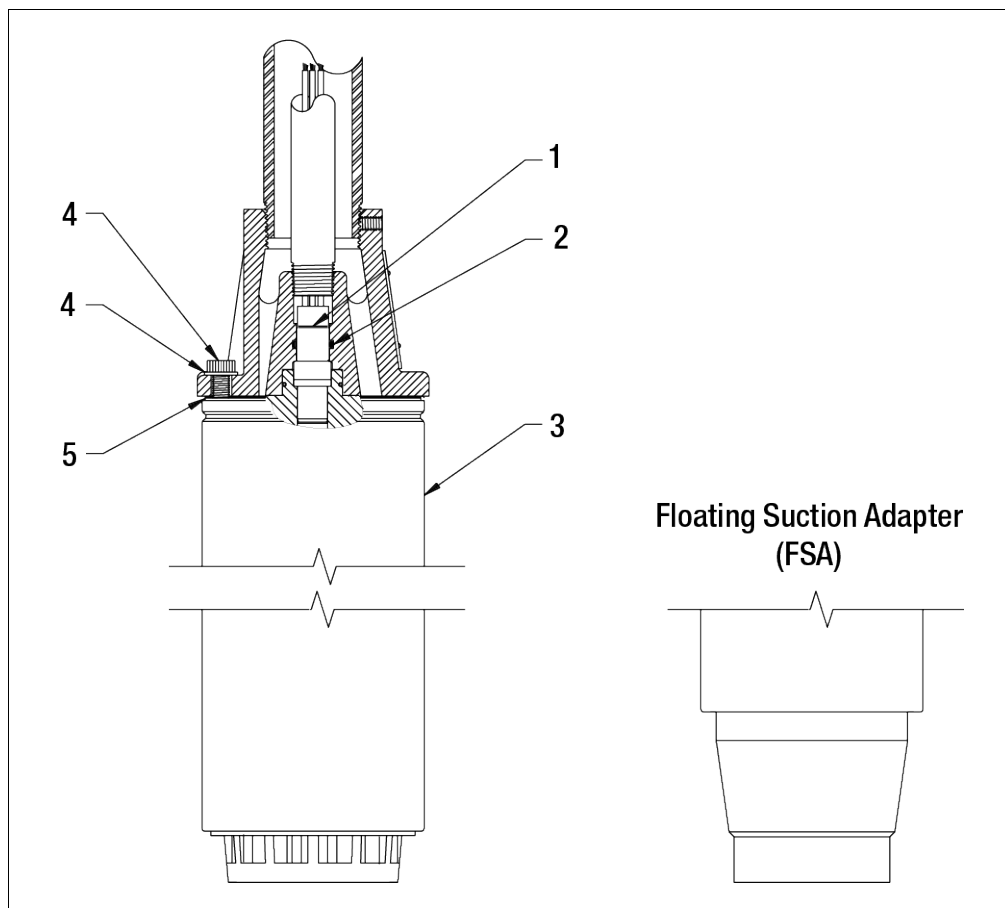

Figure 41. Pump Parts

Table 10. Pump Parts List

Item	Part No.	Description	DOM	INT'L
1	144-091-5	Kit - Pigtail (20 feet)	1	1
2	072-106-1	O-Ring Buna (-113) PETRO	1	1
2	072-528-1	O-Ring FKM (-113) AG	1	1
3	852-198-5	UMP33R1	1	---
3	852-024-5	UMP33R1 W/FSA	1	---
3	852-199-5	UMP75S1	1	---
3	852-025-5	UMP75S1 W/FSA	1	---
3	852-204-5	UMP75S3-3	---	1
3	852-206-5	UMP75S3-3 W/FSA	---	1
3	852-058-5	UMP75S17-3	---	1
3	852-200-5	UMP150S1	1	---
3	852-042-5	UMP150S1 W/FSA	1	---
3	852-205-5	UMP150S3-3	---	1
3	852-207-5	UMP150S3-3 W/FSA	---	1
3	852-059-5	UMP150S17-3	---	1
3	852-202-5	X3UMP150S1	1	---
3	852-203-5	X3UMP150S1 W/FSA	1	---
3	852-153-5	X4UMP150S3	---	1
3	852-154-5	X4UMP150S3 W/FSA	---	1
3	852-155-5	X4UMP150S17	---	1
3	852-156-5	X4UMP150S17 W/FSA	---	1
3	852-083-5	AGUMP33R1	1	---
3	852-134-5	AGUMP33R1 W/FSA	1	---
3	852-084-5	AGUMP75S1	1	---
3	852-135-5	AGUMP75S1 W/FSA	1	---
3	852-107-5	AGUMP75S3-3	---	1
3	852-111-5	AGUMP75S3-3 W/FSA	---	1
3	852-085-5	AGUMP150S1	1	---
3	852-136-5	AGUMP150S1 W/FSA	1	---
3	852-108-5	AGUMP150S3-3	---	1
3	852-112-5	AGUMP150S3-3 W/FSA	---	1
3	852-128-5	X3AGUMP150S1	1	---
3	852-132-5	X3AGUMP150S1 W/FSA	1	---

Table 10. Pump Parts List

Item	Part No.	Description	DOM	INT'L
3	852-061-5	UMP75U17-3 W/DH	---	1
3	852-062-5	UMP150U17-3 W/DH	---	1
3	852-074-5	UMP75U3-3 W/DH	---	1
3	852-075-5	UMP150U3-3 W/DH	---	1
3	852-080-5	AGUMP75S3-3 W/DH	---	1
3	852-081-5	AGUMP150S3-3 W/DH	---	1
3	852-105-5	AGUMP75S17-3 W/DH	---	1
3	852-106-5	AGUMP150S17-3 W/DH	---	1
3	852-145-5	AGUMP75S17-3	---	1
3	852-146-5	AGUMP150S17-3	---	1
3	852-147-5	AGUMP75S17-3 W/FSA	---	1
3	852-148-5	AGUMP150S17-3 W/FSA	---	1
3	852-157-5	X4UMP150U3 W/DH	---	1
3	852-158-5	X4UMP150U17 W/DH	---	1
3	852-215-5	X4AGUMP150S3	---	1
3	852-216-5	X4AGUMP150S3 W/FSA	---	1
3	852-217-5	X4AGUMP150S17	---	1
3	852-218-5	X4AGUMP150S17 W/FSA	---	1
3	852-219-5	UMP75U17-3 W/FSA	---	1
3	852-220-5	UMP150U17-3 W/FSA	---	1
4	144-328-4	Kit - Flex Siphon/UMP (includes gasket, lockwashers and bolts)	1	1
---	144-194-5	Trapper - Retrofit (not shown)	1	1
---	144-212-5	Kit - Repair, Quick Set O-Ring (Not Shown)	1	1

Control Boxes

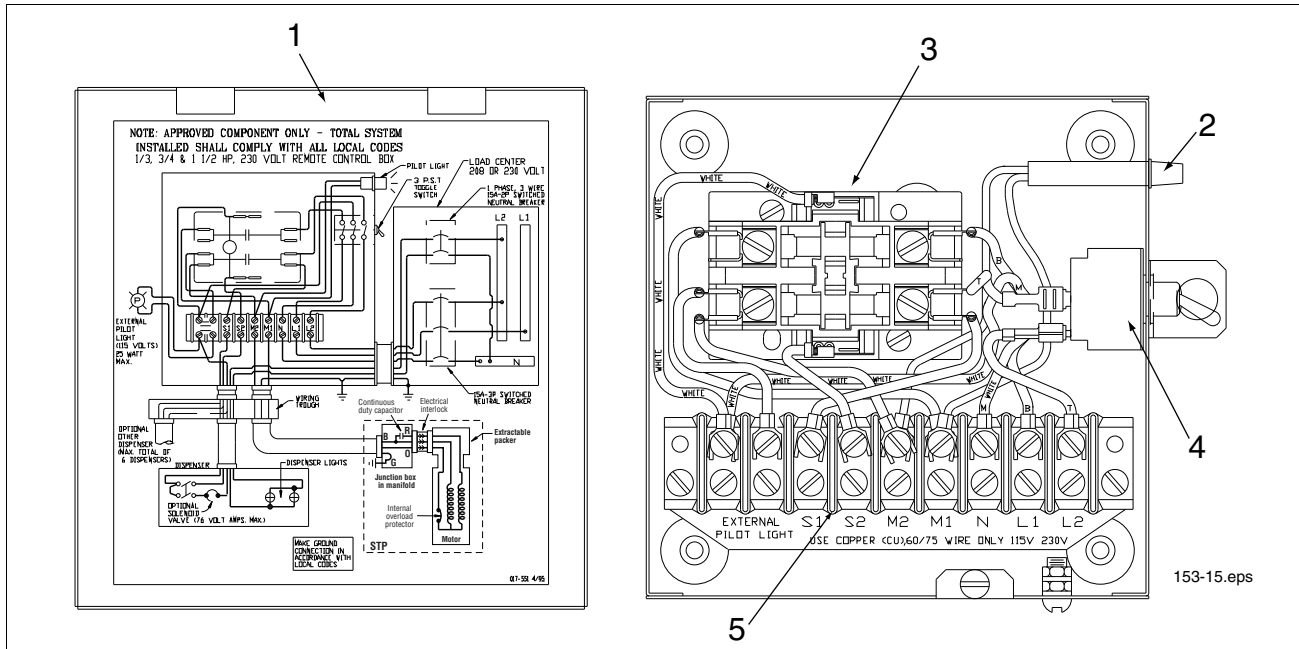

Figure 42. 880-041-5/880-042-5 Control Box

Table 11. 880-041-5 Control Box W/115V Coil (60 Hz)

Item (Ref. Figure 42)	Part No.	Description	Qty.
1	108-572-4	Control box	1
2	147-006-1	Pilot light ass'y	1
3	014-723-1	Line contractor relay	1
4	080-858-1	Toggle switch	1
5	008-202-1	Terminal block	1

Table 12. 880-042-5 Control Box W/230V Coil (50/60 Hz)

Item (Ref. Figure 42)	Part No.	Description	Qty.
1	108-572-4	Control box	1
2	147-006-1	Pilot light ass'y	1
3	014-720-1	Line contractor relay	1
4	080-858-1	Toggle switch	1
5	008-202-1	Terminal block	1

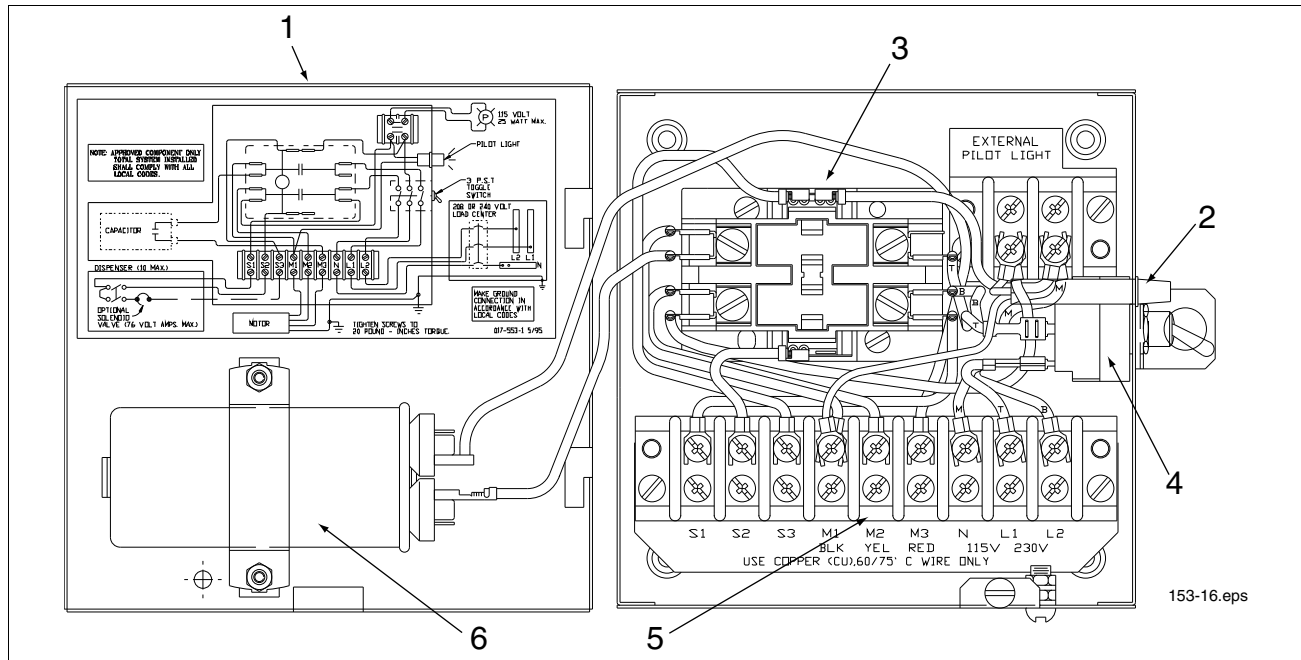

Figure 43. 880-045-5/880-046-5 Control Box

Table 13. 880-045-5 1/3 & 3/4 HP Control Box W/Cap (115V Coil)

Item (Ref. Figure 43)	Part No.	Description	Qty.
1	123-141-1	Control box	1
2	147-006-1	Pilot light ass'y	1
3	014-723-1	Line contractor relay	1
4	080-858-1	Toggle switch	1
5	008-202-1	Terminal block	1
6	111-092-5	Capacitor	1

Table 14. 880-046-5 All 1-1/2 HP Control Box W/Cap (115V Coil)

Item (Ref. Figure 43)	Part No.	Description	Qty.
1	123-141-1	Control box	1
2	147-006-1	Pilot light ass'y	1
3	014-723-1	Line contractor relay	1
4	080-858-1	Toggle switch	1
5	008-202-1	Terminal block	1
6	111-661-5	Capacitor	1

The City of New York Fire Department Conditions of Approval Certificate of Approval #4939

1. Motor wiring shall be in accordance with the New York City Electrical code for hazardous locations.
2. The installation and use of pumps shall comply with applicable New York City Code, rules and regulations including 3RCNY § 21-20 and/or 3RCNY § 21-21. Manufacturer's and Underwriters Laboratories Inc.'s safety requirements and limitations shall be complied with.
3. Pumps shall be Underwriters Laboratories Inc. listed and pump manufacturer shall retain follow up service requirements of Underwriters Laboratories Inc.
4. Equipment shall have secured and shall maintain all required approvals and shall meet all applicable Federal and State requirements. The use of this product shall be limited to the indicated intent and has not been acceptable for other uses or applications.
5. Certificate of Approval number shall be plainly and permanently stamped or otherwise fixed upon each pump by the manufacturer. NOTE: Product must already be identified with Certificate of Approval number before it arrives at New York City job site.
6. The Certificate of Approval is issued upon condition that the material or equipment's technology does not violate any patent, trade name, trade secret or other intellectual right.
7. The Fire Department Certificate of Approval does not constitute an endorsement or recommendation of your product by the Fire Department, but is a certification that your product, as represented, meets the standards as of the date of issuance.
8. The Fire Department's conditions of approval shall be enumerated in the installation manuals and brochures that will be provided to New York City buyers, users and installers.
9. The Fire Department reserves the right to withdraw this approval at any time in the event there is a reasonable doubt that the product does not operate or perform as required by code, the conditions of this resolution or as represented in your application.
10. As the manufacturer of this equipment/material, you should be aware that any end user who fails to comply with the condition as outlined in the approval will be subject to enforcement action which may include fines and imprisonment.

Pursuant to §15-220.1 of the New York City Administrative Code, any person who shall knowingly make a false statement or who shall knowingly falsify or allow to be falsified any Certificate of Approval application shall be punished by a fine of not less than one thousand dollars (\$1,000.00) and not more than five thousand dollars (\$5,000.00) or by imprisonment not to exceed six months, or both, for each such offense.

