



Introduction

This document provides instructions for installing the NPT Discharge Kit (M06648K001) on Atlas™ units.

Intended Users

The intended users of this document are Authorized Service Contractors (ASCs), Software Quality Assurance (SQA) and Manufacturing personnel.

Abbreviations and Acronyms

The following table contains a list of acronyms used in this document.

| Term | Expansion |
|-------------|-------------------------------|
| ASC | Authorized Service Contractor |
| SQA | Software Quality Assurance |

Warranty

For information on warranty, refer to Gasboy's Warranty Policy Statement - MDE-4255. If you have any warranty-related questions, contact Gasboy's Warranty Department at its Greensboro location.

Required Tools

- 13 mm socket and ratchet
- Pipe wrench
- Channel-lock pliers (2 sets or other means of tightening 2 fittings, for example vise)

Parts List

The M06648K001 kit contains the following parts:

| Description | Part Number | Quantity |
|--|-------------|----------|
| 1-inch Std. Pipe X 6.88 | R11495-123 | 1 |
| Fitting, Discharge Meter Hose | M04624B020 | 1 |
| O-ring .862 X .103 | N16891-32 | 1 |
| Bracket, Discharge Mount Discharge Kit | M06642B001 | 1 |
| Screw Metric M8 X 25 | M00415B011 | 2 |
| Plate, Discharge Blanking | M06432A002 | 1 |
| Nut, Metric, Hex Serrd Flanged (M8) | M00414B003 | 6 |
| U-Bolt Metric | M00703B001 | 1 |
| Grommet, Discharge 1-inch Pipe | 028960 | 1 |
| Elbow 1-inch X 90 Degree Painted | 024895 | 1 |

Figure 1: Discharge Kit

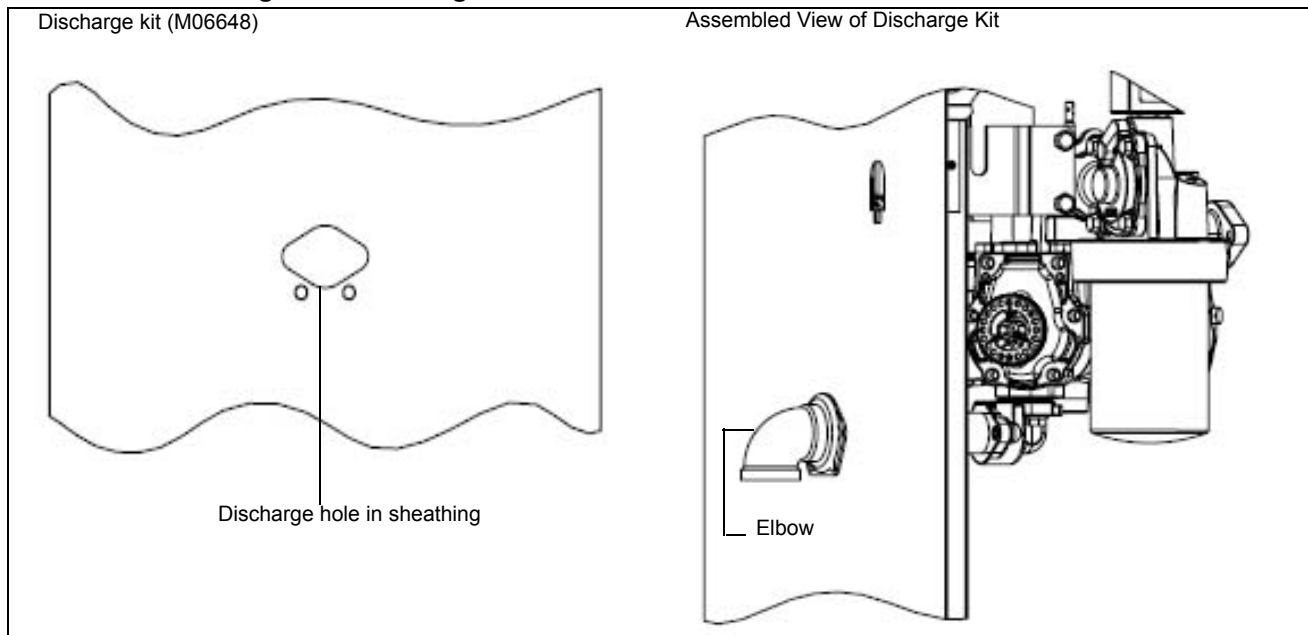

Note: This kit is for Atlas units with the sheathing configuration shown above.

Important Safety Information

This section introduces the hazards and safety precautions associated with installing, inspecting, maintaining or servicing this product. Before performing any task on this product, read this safety information and the applicable sections in this manual, where additional hazards and safety precautions for your task will be found. Fire, explosion, electrical shock or pressure release could occur and cause death or serious injury, if these safe service procedures are not followed.

Preliminary Precautions

You are working in a potentially dangerous environment of flammable fuels, vapors, and high voltage or pressures. Only trained or authorized individuals knowledgeable in the related procedures should install, inspect, maintain or service this equipment.

Emergency Total Electrical Shut-Off

The first and most important information you must know is how to stop all fuel flow to the pump/dispenser and island. Locate the switch or circuit breakers that shut off all power to all fueling equipment, dispensing devices, and Submerged Turbine Pumps (STPs).

⚠ WARNING

The EMERGENCY STOP, ALL STOP, and PUMP STOP buttons at the cashier's station WILL NOT shut off electrical power to the pump/dispenser. This means that even if you activate these stops, fuel may continue to flow uncontrolled.

You must use the TOTAL ELECTRICAL SHUT-OFF in the case of an emergency and not the console's ALL STOP and PUMP STOP or similar keys.

Total Electrical Shut-Off Before Access

Any procedure that requires access to electrical components or the electronics of the dispenser requires total electrical shut off of that unit. Understand the function and location of this switch or circuit breaker before inspecting, installing, maintaining, or servicing Gasboy equipment.

Evacuating, Barricading and Shutting Off

Any procedure that requires access to the pump/dispenser or STPs requires the following actions:



- An evacuation of all unauthorized persons and vehicles from the work area
- Use of safety tape, cones or barricades at the affected unit (s)
- A total electrical shut-off of the affected unit (s)

Read the Manual

Read, understand and follow this manual and any other labels or related materials supplied with this equipment. If you do not understand a procedure, call a Gasboy Authorized Service Contractor or call the Gasboy Support Center at 1-800-800-7498. It is imperative to your safety and the safety of others to understand the procedures before beginning work.

Follow the Regulations

Applicable information is available in National Fire Protection Association (NFPA) 30A; *Code for Motor Fuel Dispensing Facilities and Repair Garages*, NFPA 70; *National Electrical Code (NEC)*, Occupational Safety and Hazard Association (OSHA) regulations and federal, state, and local codes. All these regulations must be followed. Failure to install, inspect, maintain or service this equipment in accordance with these codes, regulations and standards may lead to legal citations with penalties or affect the safe use and operation of the equipment.

Replacement Parts

Use only genuine Gasboy replacement parts and retrofit kits on your pump/dispenser. Using parts other than genuine Gasboy replacement parts could create a safety hazard and violate local regulations.

Safety Symbols and Warning Words

This section provides important information about warning symbols and boxes.

Alert Symbol



This safety alert symbol is used in this manual and on warning labels to alert you to a precaution which must be followed to prevent potential personal safety hazards. Obey safety directives that follow this symbol to avoid possible injury or death.

Signal Words

These signal words used in this manual and on warning labels tell you the seriousness of particular safety hazards. The precautions below must be followed to prevent death, injury or damage to the equipment:



DANGER: Alerts you to a hazard or unsafe practice which will result in death or serious injury.



WARNING: Alerts you to a hazard or unsafe practice that could result in death or serious injury.



CAUTION with Alert symbol: Designates a hazard or unsafe practice which may result in minor injury.

CAUTION without Alert symbol: Designates a hazard or unsafe practice which may result in property or equipment damage

Working With Fuels and Electrical Energy

Prevent Explosions and Fires

Fuels and their vapors will explode or burn, if ignited. Spilled or leaking fuels cause vapors. Even filling customer tanks will cause potentially dangerous vapors in the vicinity of the dispenser or island.

No Open Fire



Open flames from matches, lighters, welding torches or other sources can ignite fuels and their vapors.

No Sparks - No Smoking



Sparks from starting vehicles, starting or using power tools, burning cigarettes, cigars or pipes can also ignite fuels and their vapors. Static electricity, including an electrostatic charge on your body, can cause a spark sufficient to ignite fuel vapors. Every time you get out of a vehicle, touch the metal of your vehicle, to discharge any electrostatic charge before you approach the dispenser island.

Working Alone

It is highly recommended that someone who is capable of rendering first aid be present during servicing. Familiarize yourself with Cardiopulmonary Resuscitation (CPR) methods, if you work with or around high voltages. This information is available from the American Red Cross. Always advise the station personnel about where you will be working, and caution them not to activate power while you are working on the equipment. Use the OSHA Lockout/ Tagout procedures. If you are not familiar with this requirement, refer to this information in the service manual and OSHA documentation.

Working With Electricity Safely

Ensure that you use safe and established practices in working with electrical devices. Poorly wired devices may cause a fire, explosion or electrical shock. Ensure that grounding connections are properly made. Take care that sealing devices and compounds are in place. Ensure that you do not to pinch wires when replacing covers. Follow OSHA Lockout/Tagout requirements. Station employees and service contractors need to understand and comply with this program completely to ensure safety while the equipment is down.

Hazardous Materials

Some materials present inside electronic enclosures may present a health hazard if not handled correctly. Ensure that you clean hands after handling equipment. Do not place any equipment in the mouth.

WARNING

The pump/dispenser contains a chemical known to the State of California to cause cancer.

WARNING

The pump/dispenser contains a chemical known to the State of California to cause birth defects or other reproductive harm.

In an Emergency

Inform Emergency Personnel

Compile the following information and inform emergency personnel:

- Location of accident (for example, address, front/back of building, and so on)
- Nature of accident (for example, possible heart attack, run over by car, burns, and so on)
- Age of victim (for example, baby, teenager, middle-age, elderly)
- Whether or not victim has received first aid (for example, stopped bleeding by pressure, and so on)
- Whether or not a victim has vomited (for example, if swallowed or inhaled something, and so on)

WARNING



Gasoline ingested may cause unconsciousness and burns to internal organs.
Do not induce vomiting.
Keep airway open.
Oxygen may be needed at scene.
Seek medical advice immediately.

WARNING



Gasoline inhaled may cause unconsciousness and burns to lips, mouth and lungs.
Keep airway open.
Seek medical advice immediately.

WARNING



Gasoline spilled in eyes may cause burns to eye tissue.
Irrigate eyes with water for approximately 15 minutes.
Seek medical advice immediately.

WARNING





Gasoline spilled on skin may cause burns.
Wash area thoroughly with clear water.
Seek medical advice immediately.

IMPORTANT: Oxygen may be needed at scene if gasoline has been ingested or inhaled. Seek medical advice immediately.

Lockout/Tagout

Lockout/Tagout covers servicing and maintenance of machines and equipment in which the unexpected energization or start-up of the machine(s) or equipment or release of stored energy could cause injury to employees or personnel. Lockout/Tagout applies to all mechanical, hydraulic, chemical or other energy, but does not cover electrical hazards. Subpart S of 29 CFR Part 1910 - Electrical Hazards, 29 CFR Part 1910.333 contains specific Lockout/ Tagout provision for electrical hazards.

Hazards and Actions

| | |
|---|--|
|  | WARNING |
|  | Spilled fuels, accidents involving pumps/dispensers, or uncontrolled fuel flow create a serious hazard. |
|  | Fire or explosion may result, causing serious injury or death. Follow established emergency procedures. |

The following actions are recommended regarding these hazards:

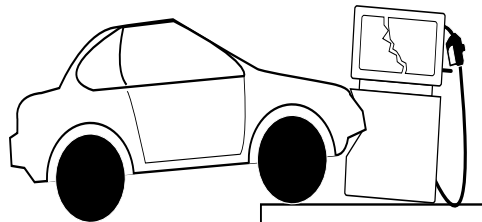

Collision of a Vehicle with Unit



Fire at Island

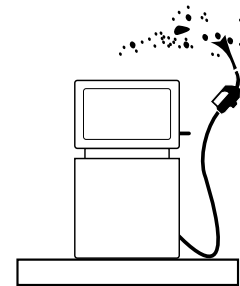

Fuel Spill

- Do not go near a fuel spill or allow anyone else in the area.
- Use station EMERGENCY CUTOFF immediately. Turn off all system circuit breakers to the island(s).
- Do not use console E-STOP, ALL STOP and PUMP STOP to shut off power. These keys do not remove AC power and do not always stop product flow.
- Take precautions to avoid igniting fuel. Do not allow starting of vehicles in the area. Do not allow open flames, smoking or power tools in the area.
- Do not expose yourself to hazardous conditions such as fire, spilled fuel or exposed wiring.
- Call emergency numbers.

This page is intentionally left blank.

Installing Atlas NPT Discharge Kit (M06648K001)

To install the Atlas Discharge Kit, proceed as follows:

- 1 Remove the existing discharge fitting from the exterior of the unit, copper discharge tube and meter discharge fitting.

Figure 2: Discharge Kit Assembly

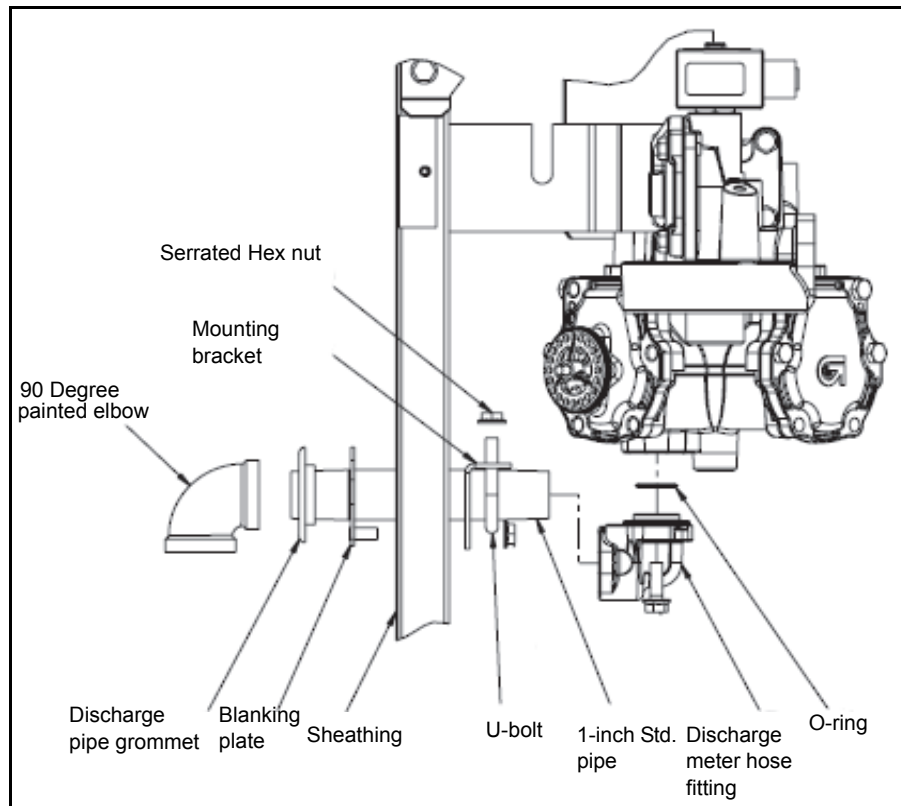

- 2 Apply pipe sealant to the threads of the 1-inch pipe nipple (R11495-123).
Note: Use sealant approved for use with petroleum products.
- 3 Insert the nipple into the discharge fitting (M04624B020) and tighten it.
Note: Ensure that you do not overtighten the nipple.
- 4 Apply oil to the O-ring (N16891-32) and insert it into the O-ring groove in the meter discharge.
Note: Ensure that the O-ring is properly aligned with the grooves while inserting.

Installing Atlas NPT Discharge Kit (M06648K001)

- 5 Slide the discharge mounting bracket (M06642B001) over the nipple.
- 6 Inserting the open nipple end through the discharge hole in the frame, insert the discharge fitting (M04624B020) into the meter discharge and place and tighten the (2) screws (M00415B011).
- 7 Slide the discharge blanking plate (M06432A002) over the nipple protruding on the outside of the unit so that the attached clinch-studs are inserted through the frame.
- 8 Slide the discharge mounting bracket (M06642B001) to the frame capturing the clinch studs on the blanking plate through the holes in the discharge mounting bracket. Place (4) M8 flanged nuts (M00414B003) to the studs and tighten.
- 9 Slide the U-bolt (M00703B001) through the holes on top of the discharge mounting bracket so that it captures the nipple. Place (2) M8 flanged nuts (M00414B003) to the U-bolt and tighten them.
- 10 Slide the discharge grommet (028960) over the end of the nipple to where the rear face of the grommet is against the blanking plate.
- 11 Apply pipe sealant to the threads of the 1-inch painted elbow (024895), screw it onto the nipple and tighten the elbow.
Note: While tightening the elbow, use a cloth to wrap the elbow or some other means of protecting the elbow's finish.
- 12 Reattach hoses and hardware. After purging air from unit, check for leaks.



GASBOY

© 2005 GASBOY

7300 West Friendly Avenue • Post Office Box 22087
Greensboro, North Carolina 27420

Phone 1-800-444-5529 • <http://www.gasboy.com> • Printed in the U.S.A.

MDE- 4533 Instructions for Installing Atlas NPT Discharge Kit (M06648K001) • December 2005