

Installation Instructions

Replacement of CPT Controller door

The following terms are used throughout this document to bring attention to the presence of hazards of various risk levels, or to important information concerning use of the product

DANGER!!	Indicates the presence of a hazard that will cause severe personal injury, death, or substantial property damage if ignored .	Caution	Indicates the presence of a hazard that will or can cause minor personal injury or property damage if ignored .
WARNING!	Indicates the presence of a hazard that can cause severe personal injury, death, or substantial property damage if ignored .	Notice	Indicates special instructions on installation, operation, or maintenance that are important but not related to personal injury hazards.

- 1) Lock out and tag out electrical power to the CPT Controller at the service panel.

Warning!	Voltage stored in the capacitor band of the CPT Controller presents a risk of POTENTIALLY LETHAL ELECTRICAL SHOCK EVEN AFTER THE POWER IS DISCONNECTED . After disconnecting the power, wait 5 minutes. Verify that the red capacitor charge LED on the inverter board has gone out, before servicing or removing the controller.
-----------------	--

- 2) Open the CPT door and disconnect the ribbon cable from connector J5 on the MPU board. see figure 1.

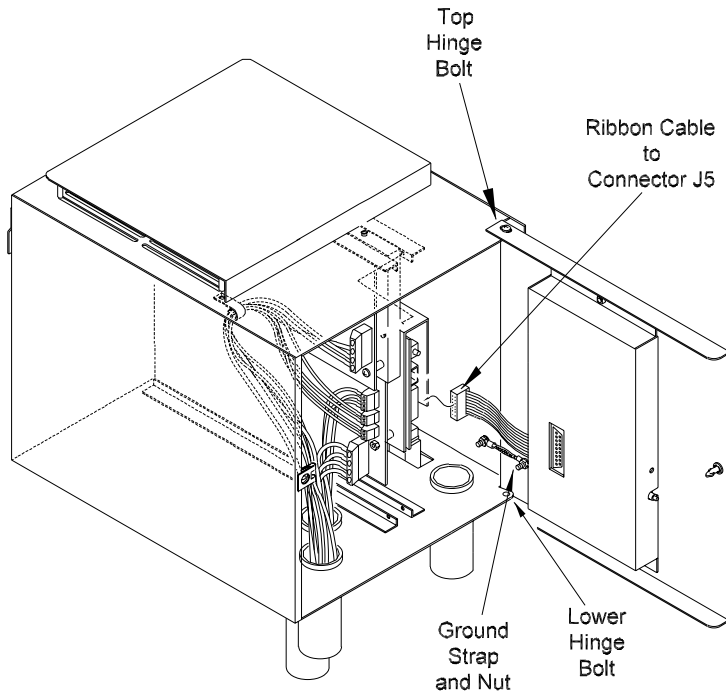

Caution

DO NOT TWIST the ribbon cable when reconnecting to connector J5.

A twisted ribbon cable will destroy the inverter board!!

- 3) Disconnect the ground strap from the door. **DO NOT** lose the nut and lock washer! Refer to figure 1.

- 4) Remove and save the upper and lower door hinge bolts. Remove the door.
- 5) Position the replacement CPT door and reinstall the upper and lower hinge bolts.
- 6) Reconnect the ground strap to the door.

Caution

DO NOT TWIST the ribbon cable when reconnecting to connector J5. This will damage or destroy the inverter board assembly!!

- 7) Reconnect the ribbon cable to connector J5 on the MPU board.
- 8) Close the door and reapply electrical power to the CPT Controller.



by  **VEEDER-ROOT**

125 Powder Forest Drive • Simsbury, CT 06070
Tel: (860) 651-2700 • Fax: (860) 651-2719

ARE260-308 REV. C
