

VEEDER-ROOT **INSTALLATION INSTRUCTIONS**

Technical Manual
9-002
Issued: 4/99
Supersedes: 8/85

Rev. B

INSTALLATION OF SERIES 7856 ELECTRICAL KNOCKOFF SWITCH ON VEEDER-ROOT METER PRESETS **Manual No. 251313 Rev. B**

WARNING: VEEDER-ROOT METER PRESETS EQUIPPED WITH AN ELECTRICAL KNOCKOFF SWITCH MUST BE USED WITH FAIL-SAFE BACKUP EQUIPMENT TO PREVENT ACCIDENTAL RUNAWAY DELIVERY OF PRODUCT. FAILURE TO PROVIDE BACKUP EQUIPMENT COULD RESULT IN PERSONAL INJURY, PROPERTY LOSS AND EQUIPMENT DAMAGE.

WARNING: IN INSTALLATION AND USE OF THIS PRODUCT, COMPLY WITH THE NATIONAL ELECTRICAL CODE; FEDERAL, STATE AND LOCAL CODES; AND ANY OTHER APPLICABLE SAFETY CODES. IN ADDITION, TURN OFF POWER AND TAKE OTHER NECESSARY PRECAUTIONS DURING INSTALLATION, SERVICE AND REPAIR TO PREVENT PERSONAL INJURY, PROPERTY LOSS AND EQUIPMENT DAMAGE.

Note: When a vertical bar **|** appears adjacent to text or illustrations, information has been added or changed at the last issue date.

This switch assembly may be installed on the Preset in one of two locations: the right side or left rear.

GENERAL. The Series 7856 Switch Assembly has four internal switches to provide FULL FLOW, LOW FLOW and OFF control for Veeder-Root Series 7889 Meter Presets.

INSTALLING SWITCH. To have adequate access to install the switch, it may be necessary to remove the preset from its mounting.

If moisture enters the inside of the electrical knockoff switch housing (Figure 1) during installation or repair, freezing temperatures could later restrict switch contact operation and result in a runaway delivery of product. To prevent this potentially dangerous condition, protect the switches from rain and snow when the cover is removed. Ensure that switches are dry, then install the cover and tighten mounting screws to keep moisture out.

WARNING: ELECTRICAL KNOCKOFF SWITCH MUST BE PROTECTED FROM RAIN AND SNOW WHEN COVER IS REMOVED. ENSURE THAT SWITCHES ARE DRY, THEN INSTALL COVER AND TIGHTEN MOUNTING SCREWS TO KEEP MOISTURE OUT. FAILURE TO FOLLOW THIS WARNING COULD RESULT IN A RUNAWAY DELIVERY OF PRODUCT WITH SUBSEQUENT PERSONAL INJURY, PROPERTY LOSS AND EQUIPMENT DAMAGE.

1. Determine best location for the switch: right side or left rear, Figure 1. Remove the thru-bolt from the appropriate corner of the preset.

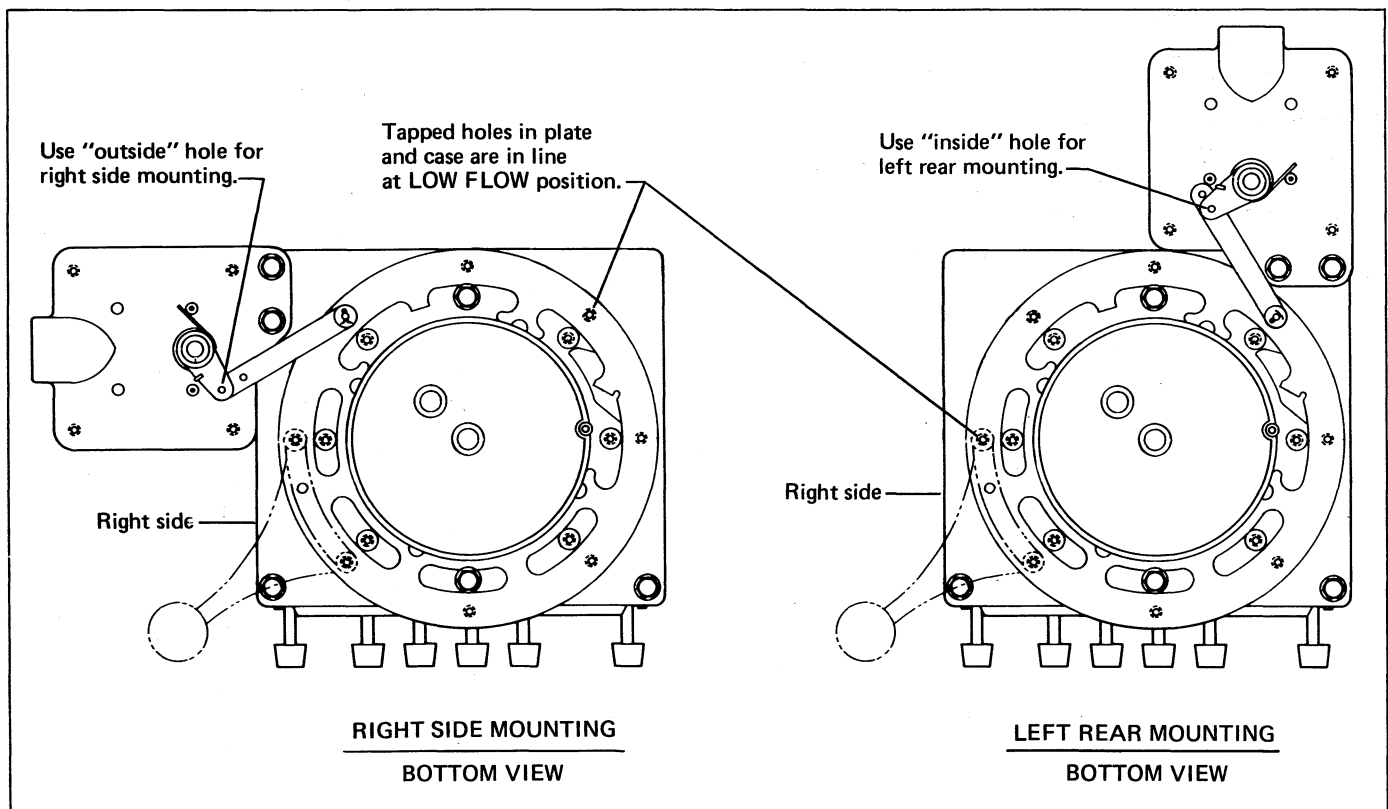

Figure 1. Typical Knockoff Switch Mounting Positions

2. Position the switch on the preset mounting surface. Install a new thru-bolt, P/N 503300-113, and lock washer to secure the switch flange at the corner. Install the second washer and mounting bolt, P/N 503619-001. Tighten both bolts hand tight.
3. Rotate the knockoff plate to the LOW FLOW position. Install the link stud in the ring at the proper location, Figure 1.
4. Attach the link from the stud to the switch shaft lever and secure with washers and cotter pins. Cotter pins must be bent as shown in Figure 2.

Note: After cotter pins are installed, actuate linkage to be sure there is no interference with case.

- A. For switches mounted on the left rear, use the inside hole (located 2-13/16" from stud hole).
 - B. For switches mounted on the right side, use the outside hole (located 3-5/16" from stud hole).
5. Position the handle on the knockoff plate in location desired for proper operating and full travel when the preset is reinstalled. Secure with lock washers and cap screws.

Note: Handle may be located in any position on the knockoff plate except at the link stud.

ADJUSTING KNOCKOFF SWITCHES. All internal switches are adjusted at the factory before shipment and should not require readjustment by the user. Electrical knockoff switches that are shipped loose can be mounted on a preset in the field without further adjustment. If the switch is moved from one position to another, only the linkage relationship has to be changed. If internal switches are replaced or disrupted, however, switch lever-to-actuator measurement must be made and adjusted as required to obtain proper dimension.

1. Set the knockoff plate in the LOW FLOW position.
2. Insert a feeler gage of proper thickness specified in Figure 3 between the switch lever and actuator.
3. Loosen the switch plate screws. Adjust the plate so the switch actuates at this point.
4. Tighten the switch plate screws to 8 to 10 lb-in.
5. Rotate the knockoff plate to its extreme positions and make sure that the switch levers do not make contact with the plastic switch cases.
6. If the switch levers make contact, realign the explosion-proof housing before tightening mounting bolts.
7. Tighten mounting bolts to 8 to 10 lb-in.

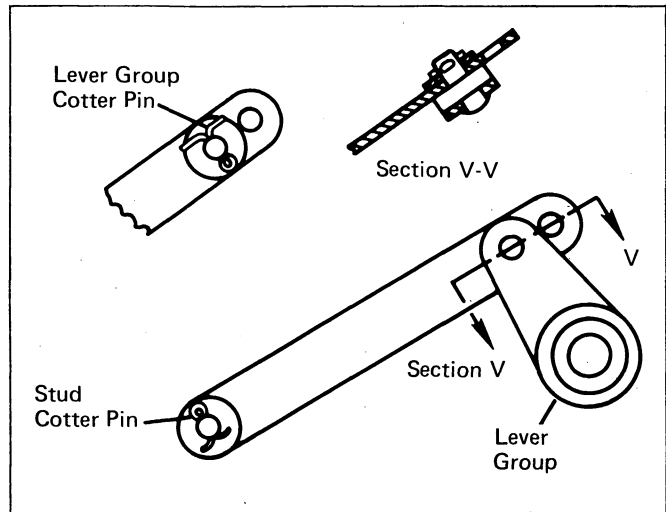

Figure 2. Proper Bend of Cotter Pins.

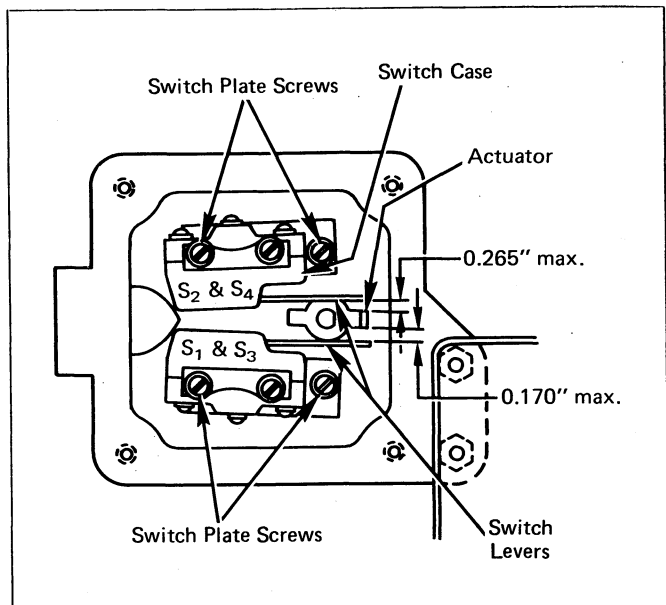

Figure 3. Switch Adjustment.

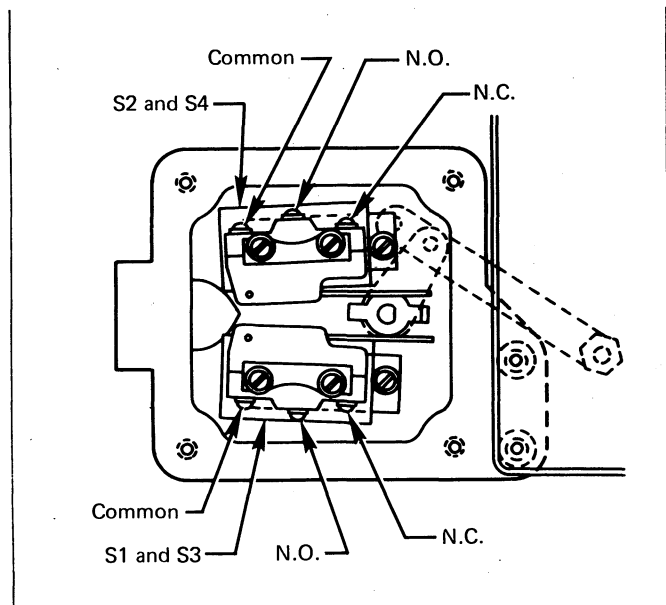

Figure 4. Switch Contacts.

CONNECTING WIRES TO SWITCH TERMINALS.

WARNING: MAIN POWER MUST BE DISCONNECTED BEFORE INSTALLING WIRES TO SWITCH TERMINALS TO PREVENT PERSONAL INJURY, PROPERTY LOSS AND EQUIPMENT DAMAGE.

1. Switches are SPDT, with capacity of 115 VAC or 230 VAC, 50/50 Hz, at 15 amperes; 125 VAC, at 1/2 ampere; 250 VDC, at 1/4 ampere. Each terminal is identified by markings on the switch body (see Figure 4). Use wires of 12 AWG maximum.
2. Thread size is 3/4-14 American Standard taper pipe thread — 0.732 in. min. full thread depth.

Note: See National Electrical Code for size of wire, number of wires allowed in conduit and conduit sealing requirements.

3. After selecting the circuit hookup for proper operation or control (Figure 5) connect leads.
4. Install switch cover. Secure with external tooth lock washers and bolts.

CAUTION: AFTER REINSTALLING THE PRESET AND BEFORE RELEASING IT FOR NORMAL OPERATION, MAKE A LIVE OPERATION CHECK TO BE SURE CIRCUITS PROVIDE PROPER CONTROL TO PREVENT EQUIPMENT DAMAGE.

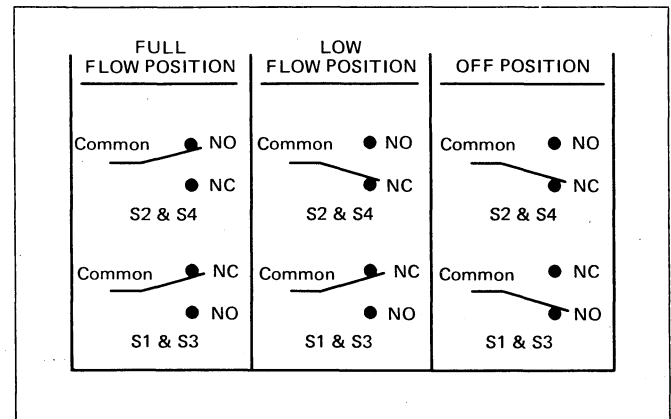

Figure 5. Switch Circuits.

OPERATION

1. Veeder-Root meter presets equipped with an electrical knockoff switch must be used with fail-safe backup equipment to prevent accidental runaway delivery of product.

WARNING: VEEDER-ROOT METER PRESETS EQUIPPED WITH AN ELECTRICAL KNOCKOFF SWITCH MUST BE USED WITH FAIL-SAFE BACKUP EQUIPMENT TO PREVENT ACCIDENTAL RUNAWAY DELIVERY OF PRODUCT. FAILURE TO PROVIDE BACKUP EQUIPMENT COULD RESULT IN PERSONAL INJURY, PROPERTY LOSS AND EQUIPMENT DAMAGE.

2. During cold weather operation, periodically ensure that the electrical knockoff switch is functioning properly. Perform this test by depressing the meter preset STOP button during a delivery, but prior to final knockoff. If shutdown occurs, the switch is functioning properly.

WARNING: PERIODICALLY CHECK FOR PROPER OPERATION OF ELECTRICAL KNOCKOFF SWITCH IN COLD WEATHER. PERFORM THIS TEST BY DEPRESSING METER PRESET STOP BUTTON DURING A DELIVERY, BUT PRIOR TO FINAL KNOCKOFF. FAILURE TO DO THIS COULD RESULT IN PERSONAL INJURY, PROPERTY LOSS AND EQUIPMENT DAMAGE.

DAMAGE CLAIMS, WARRANTY AND CONDITIONS

A. DAMAGE CLAIMS

1. Thoroughly examine the enclosure as soon as it is received. If damaged, write on the face of the freight bill a complete and detailed description of the damage. Have the carrier's agent sign the description.

Note: Insist that the carrier's agent verify the inspection and sign the description.

2. Immediately notify the delivering carrier of damage or loss. This notification may be given either in person or by telephone. Written confirmation must be mailed within 48 hours. Railroads and motor carriers are understandably reluctant to make adjustments for damaged merchandise unless inspected and reported promptly.

3. Risk of loss of, or damage to merchandise remains with the Buyer. It is the Buyer's responsibility to file a claim with the carrier involved.

4. Immediately advise your Veeder-Root representative, distributor, or the factory so that we may assist you.

B. RETURN SHIPPING. All shipments of Veeder-Root products must be prepaid. Equipment must be packed in a strong exterior container and surrounded by shock absorbing material. Veeder-Root will accept no liability for damage caused by improper packing. It is suggested that the original shipping container be used if it is available. Address shipment to Veeder-Root Co., 6th Avenue at Burns Crossing, P.O. Box 1673, Altoona, PA 16603-1673.

C. WARRANTY AND CONDITIONS

1. WARRANTY. We warrant that our products shall be free from defects in material and workmanship for a period of one year from the date of shipment thereof or the product's total rated life, whichever first occurs. Within the warranty period we shall repair or replace such products which are returned to us with shipping charges prepaid and which are determined by us to be defective. This warranty will not apply to any product which has been subjected to misuse, negligence, or accident; or misapplied; or used in violation of product manuals, instructions, or warnings; or modified or repaired by unauthorized persons; or improperly installed.

2. INSPECTION. You shall inspect the product promptly after receipt and shall notify us at our Altoona office, in writing, of any claims, including claims of breach of warranty, within thirty days after you discover or should have discovered the facts upon which the claim is based. Your failure to give written notice of a claim within the time period shall be deemed to be a waiver of such claim.

3. LIMITATION OF REMEDY AND WARRANTY. The provisions of Paragraph 1 are our sole obligation and exclude all other remedies or warranties, express or implied, including warranties of MERCHANTABILITY and FITNESS FOR A PARTICULAR PURPOSE, whether or not purposes or specifications are described herein. We further disclaim any responsibility whatsoever to you or to any other person for injury to person or damage to or loss of property or value caused by any product which has been subjected to misuse, negligence, or accident; or misapplied; or used in violation of product manuals, instructions, or warnings; or modified or repaired by unauthorized persons; or improperly installed.

4. LIMITATION OF DAMAGES. Under no circumstances shall we be liable for any incidental, consequential or special damages, losses or expenses arising from this contract or its performance or in connection with the use of, or inability to use, our product for any purpose whatsoever.

5. LIMITATION OF ACTIONS. No action regardless of form arising out of this contract may be commenced more than one year after the cause of action has accrued, except an action for nonpayment.

6. COLLATERAL PROMISES. There are no representations, warranties, or conditions express or implied, statutory or otherwise except those herein contained, and no agreements or waivers collateral hereto shall be binding on either party unless in writing and signed by you and accepted by us at our Altoona office.

7. INTERPRETATION. Rights and liabilities arising out of any contract with us shall be determined under the Uniform Commercial Code as enacted in Connecticut.



6th Avenue at Burns Crossing, P.O. Box 1673, Altoona, PA 16603-1673 Phone (814) 695-4476, or (800) 873-3313, Fax (814) 695-7605, or (800) 234-5350

BRAZIL: Sao Paulo • CANADA: Mississauga, Ontario • ENGLAND: Richmond Surrey • FRANCE: Aulnay-Sous-Bois • GERMANY: Aldingen • SINGAPORE: Singapore