

Mag Plus Probe 1” Float

Installation Guide

Veeder-Root Authorised Representative is

<p>Veeder-Root Environmental Systems Limited, Hydrex House, Garden Road, Richmond, Surrey TW9 4NR UNITED KINGDOM</p> <p>☎ +44 (0)20 8392 1355</p>	<p>Veeder-Root GmbH Uhlandstrasse 49 D-78554 Aldingen GERMANY</p> <p>☎ +49 (0)7424 1400</p>	<p>Veeder-Root Sarl ZI des Mardelles 94-106 rue Blaise Pascal 93600 Aulnay-sous-Bois FRANCE</p> <p>☎ +33 (0)148 795599</p>
--	--	---

And Distributors throughout Europe

Published in Great Britain by Veeder-Root Environmental Systems Limited,
Hydrex House, Garden Road, Richmond, Surrey TW9 4NR
United Kingdom

Copyright ©2001 Veeder-Root Environmental Systems Limited
All rights reserved. No part of this publication may be reproduced, stored in a retrieval system or
transmitted in any form or by any means electronic, mechanical, photocopying, recording or otherwise,
without the prior permission of Veeder-Root Environmental Systems Limited.

Introduction

Contractor Certification Requirements	1
Related Manuals	1

Installation Kit

1-Inch Float Installation Kit (846401-400)	2
--	---

Probe Components

Assembling Probe Components	3
-----------------------------------	---

Introduction

This manual describes how to identify and assemble the 1-inch float kit components for Mag Plus, Inventory Only Probes - Form Number 8463. Instructions are included for attaching spacer rings to the probe canister, assembling floats onto the probe shaft, installing probe into tank, and attaching the probe's cable to the canister.

For guidelines on site preparation, instructions on selecting the correct Mag Probe length for a tank, and instructions on connecting wiring from the Mag Probe to the console, refer to the appropriate Veeder-Root Site Preparation and Installation Manual.

Contractor Certification Requirements

Veeder-Root requires the following minimum training certifications for contractors who will install and setup the equipment discussed in this manual:

- Level 1** Contractors holding valid Level 1 Certification are approved to perform wiring and conduit routing, equipment mounting, probe and sensor installation, tank and line preparation, and line leak detector installation.
- Level 2/3** Contractors holding valid Level 2 or 3 Certifications are approved to perform installation checkout, startup, programming and operations training, troubleshooting and servicing for all Veeder-Root Tank Monitoring Systems, including Line Leak Detection and associated accessories.

Warranty Registrations may only be submitted by selected Distributors.

Related Manuals

For Mag Probe installation, consult the appropriate Site Prep and Installation Manual for your console:

- 576013-879 TLS-300/TLS-350 Series Consoles Site Prep and Installation Manual
- 576013-977 Guardian AST Monitoring System Site Prep and Installation Manual

Installation Kit

1-Inch Float Installation Kit (846401-400)

Mag Plus, Inventory Only Probes (8463) with 1-inch floats are shipped with the installation kit listed in Table 1 and shown in Figure 1.

Table 1. Mag Plus Probe 1-Inch Floats Installation Kit Contents

Quantity	Description	Part Numbers
1	Cable	330272-00X
1	1-inch Product Float	331773-00X
1	1-inch Water Float	330426-00X
2	Probe Canister Spacer Rings	331555-001
1	Retaining Ring	511805-365

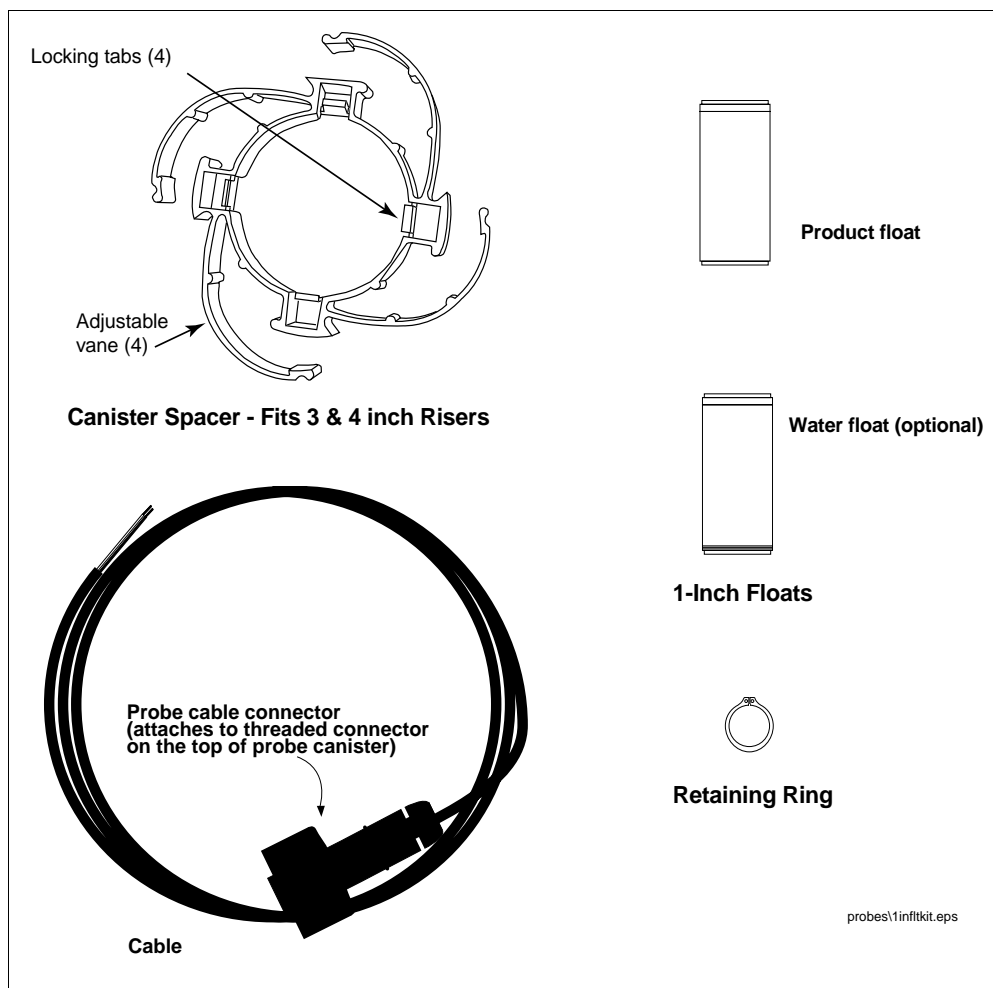

Figure 1. 1-Inch Float Installation Kit

Probe Components

Installation of the Mag Plus probe with 1-inch floats will require additional customer supplied parts/tools:

- A threaded reducer with a 2-, 3-, or 4-inch female end and an appropriately sized male end to fit into the existing threaded tank bung fitting.
- A riser pipe having a 2-, 3-, or 4-inch diameter and a length necessary to completely contain the canister and attached cable plug once the probe shaft is lowered through the installed reducer and its end is resting on the bottom of the tank.
- A riser pipe cap appropriately sized to seal onto the riser pipe, and a cord grip sized for the probe cable.
- A pair of Snap Ring pliers to attach the retaining ring to the bottom of the probe shaft.

Assembling Probe Components

1. Open the Probe shipping carton so that you have access to the probe. Also open the installation kit.
2. If you are installing the probe in a 2-inch riser, you will not need the canister spacer rings. If you are installing the probe in a 3- or 4-inch riser, then you will need to slip the spacer rings on the probe canister as shown in Figure 2. Note: you must slide the bottom spacer over the probe shaft and onto the lower end of the canister.

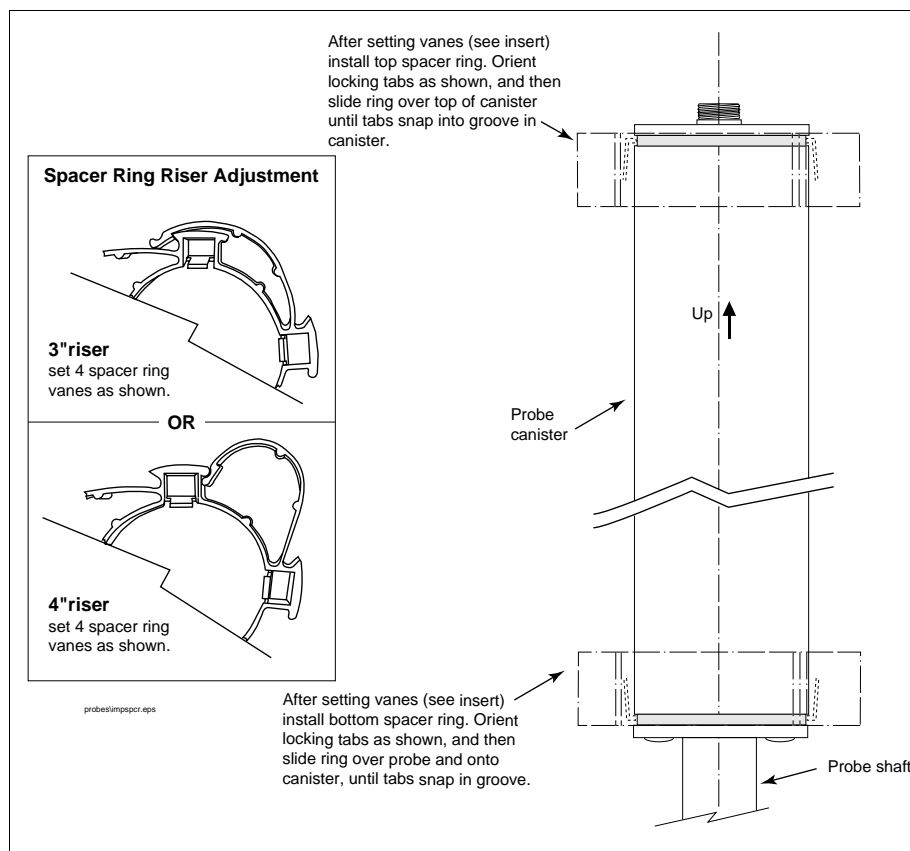

Figure 2. Installing Probe Canister Spacer Rings

3. Support the probe in a horizontal position and slide the reducer, large end first, onto the probe shaft (1).
4. Slide the Product Float onto the shaft, magnet end first (2).
5. Slide the Water Float onto the shaft making sure that the thin ballast rings on the float are facing the bottom of the shaft (3).
6. Using the Snap Ring pliers, attach the Retaining Ring in the groove at the bottom of the shaft (4).
7. Slide the floats against the Retaining Ring. While holding the reducer, carefully raise the probe and lower it into the threaded bung fitting of the tank. Screw the reducer into the tank fitting until it is tight.
8. Pass the probe cable through the riser and screw the cable's plug snugly onto the threaded fitting on top of the probe's canister.
9. Lower the riser over the probe canister and screw it tightly into the threaded reducer.
10. Install the riser cap and proceed with the accepted probe to console splicing procedure.

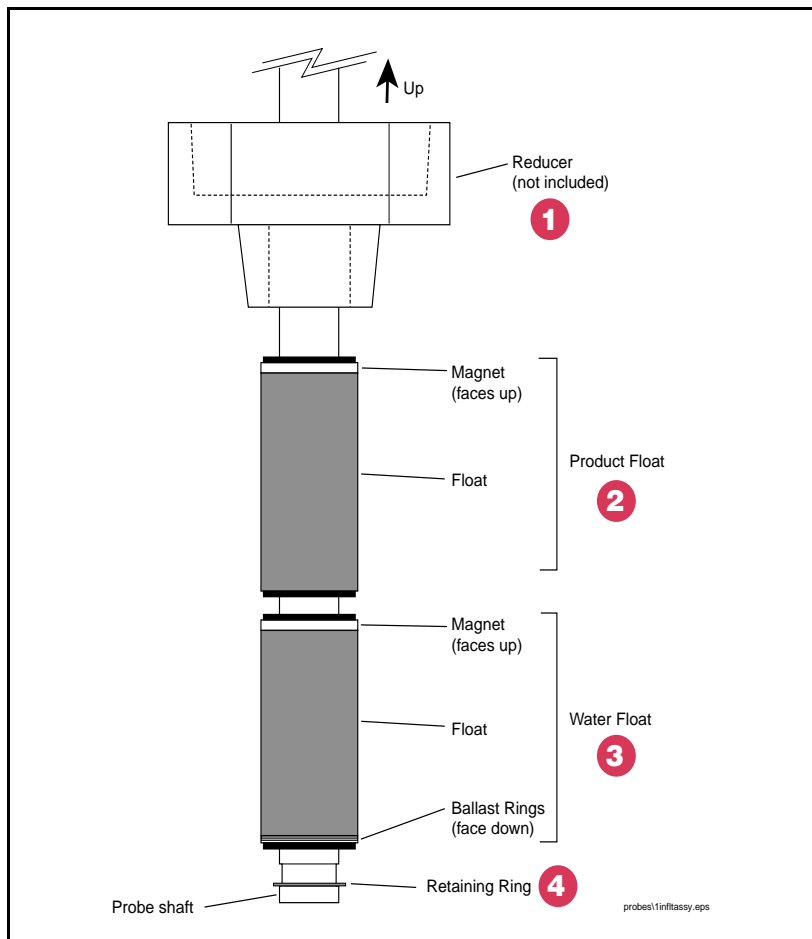

Figure 3. Installing Probe Floats and Retaining Ring

Sales Offices

Veeder-Root has offices around the world to serve you.

Headquarters

Veeder-Root Company
125 Powder Forest Drive
Simsbury, CT 06070-7684 U.S.A.
(860) 651-2700 FAX: (860) 651-2719

England

Veeder-Root Environmental Systems Limited
Hydrex House, Garden Road
Richmond, Surrey TW9 4NR ENGLAND
+44 (0)20 8392 1355

Brazil

Veeder-Root do BRASIL
Rua ado Benatti, 92
Caixa Postal 8343
01051 Sao Paulo BRAZIL
+55 (0)11 3611 2155

Germany

Veeder-Root GmbH
Uhlandstrasse 49
D-78554 Aldingen GERMANY
+49 (0)7424 1400

France

Veeder-Root SARL
ZI des Mardelles
94-106 rue Blaise Pascal
93600 Aulnay-sous-Bois FRANCE
+33 (0)1 4879 5599

Canada

Veeder-Root Canada
151 Superior Boulevard, Suite 24
Mississauga, Ontario, L5T 2L1 CANADA
905-670-2755

Singapore

Veeder-Root Singapore
246 MacPherson Road
#08-01 Betime Building
348578 Singapore
+65 (0)745 9265

Mexico

Veeder-Root Mexico
Prado de las Camelias
No. 4483-4
Praddos Tepeyac C.P. 45500
Zapopan, Jal., MEXICO
+52 (0)36-47-3750