

# Interstitial Liquid Sensor - Steel Tanks

## Installation Guide

# Notice

---

Veeder-Root makes no warranty of any kind with regard to this publication, including, but not limited to, the implied warranties of merchantability and fitness for a particular purpose.

Veeder-Root shall not be liable for errors contained herein or for incidental or consequential damages in connection with the furnishing, performance, or use of this publication.

Veeder-Root reserves the right to change system options or features, or the information contained in this publication.

This publication contains proprietary information which is protected by copyright. All rights reserved. No part of this publication may be photocopied, reproduced, or translated to another language without the prior written consent of Veeder-Root.

Contact TLS Systems Technical Support for additional troubleshooting information at 800-323-1799.

## **DAMAGE CLAIMS / LOST EQUIPMENT**

Thoroughly examine all components and units as soon as they are received. If any cartons are damaged or missing, write a complete and detailed description of the damage or shortage on the face of the freight bill. The carrier's agent must verify the inspection and sign the description. Refuse only the damaged product, not the entire shipment.

Veeder-Root must be notified of any damages and/or shortages within 30 days of receipt of the shipment, as stated in our Terms and Conditions.

## **VEEDER-ROOT'S PREFERRED CARRIER**

1. Contact Veeder-Root Customer Service at 800-873-3313 with the specific part numbers and quantities that were missing or received damaged.
2. Fax signed Bill of Lading (BOL) to Veeder-Root Customer Service at 800-234-5350.
3. Veeder-Root will file the claim with the carrier and replace the damaged/missing product at no charge to the customer. Customer Service will work with production facility to have the replacement product shipped as soon as possible.

## **CUSTOMER'S PREFERRED CARRIER**

1. It is the customer's responsibility to file a claim with their carrier.
2. Customer may submit a replacement purchase order. Customer is responsible for all charges and freight associated with replacement order. Customer Service will work with production facility to have the replacement product shipped as soon as possible.
3. If "lost" equipment is delivered at a later date and is not needed, Veeder-Root will allow a Return to Stock without a restocking fee.
4. Veeder-Root will NOT be responsible for any compensation when a customer chooses their own carrier.

## **RETURN SHIPPING**

For the parts return procedure, please follow the appropriate instructions in the "General Returned Goods Policy" pages in the "Policies and Literature" section of the Veeder-Root **North American Environmental Products** price list. Veeder-Root will not accept any return product without a Return Goods Authorization (RGA) number clearly printed on the outside of the package.

**Introduction**

Contractor Certification Requirements ..... 1  
Product Marking Information ..... 1  
    Related Documents ..... 1  
        Documents Required to Install Equipment ..... 1  
        Product Label Contents ..... 2  
Safety Warnings ..... 3  
Safety Symbols ..... 3  
Sensor Description ..... 4  
    Components Shipped ..... 4  
    Models ..... 4  
    Sensor States ..... 4

**Installation** ..... 5

**Figures**

Figure 1. Example Sensor Installation - Steel Tank ..... 5  
Figure 2. Sensor Field Wiring Diagram ..... 6  
Figure 3. Epoxy sealing example ..... 6

## Introduction

This manual contains installation procedures for the replacement of all interstitial liquid sensors for steel tanks in an existing TLS monitoring system designed and manufactured by Veeder-Root.

This manual assumes field wiring has been run from the console to the tank in which this sensor will be installed following instructions in the appropriate console's site prep manual.

### Contractor Certification Requirements

---

Veeder-Root requires the following minimum training certifications for contractors who will install and setup the equipment discussed in this manual:

**Installer (Level 1) Certification:** Contractors holding valid Installer Certification are approved to perform wiring and conduit routing; equipment mounting; probe, sensor and carbon canister vapor polisher installation; wireless equipment installation; tank and line preparation; and line leak detector installation.

**ATG Technician (Level 2/3 or 4) Certification:** Contractors holding valid ATG Technician Certifications are approved to perform installation checkout, startup, programming and operations training, system tests, troubleshooting and servicing for all Veeder-Root Series Tank Monitoring Systems, including Line Leak Detection. In addition, Contractors with the following sub-certification designations are approved to perform installation checkout, startup, programming, system tests, troubleshooting, service techniques and operations training on the designated system.

- Wireless 2
- Tall Tank

**Warranty Registrations** may only be submitted by selected Distributors.

### Product Marking Information

---

#### RELATED DOCUMENTS

##### *Documents Required to Install Equipment*

This intrinsically safe apparatus is only for use as part of a Veeder-Root Automatic Tank Gauging System (ATG Console with probes and sensors). To install intrinsically safe apparatus, use the specific control drawing that appears on the nameplate of the applicable associated apparatus (ATG Console):

Equipment	UL/cUL Control Drawing Document No.
<b>Associated Apparatus</b>	
TLS-450/8600	331940-008
TLS-350, TLS-350R	331940-011
TLS-300	331940-013
TLS4/8601	331940-018
TLS-XB/8603	331940-020

The control drawings contain information related to the correct installation of the overall intrinsically Safe System. This includes information such as maximum number of apparatus, specific apparatus allowed in the system, maximum cable lengths, references to codes, proper grounding and so on. Control drawings can be found on the

accompanying Compact Disk (TECH DOCS CD) or on the internet at [veeder.com](http://veeder.com) under SUPPORT; VR TECHNICAL DOCUMENTS; DRAWINGS.

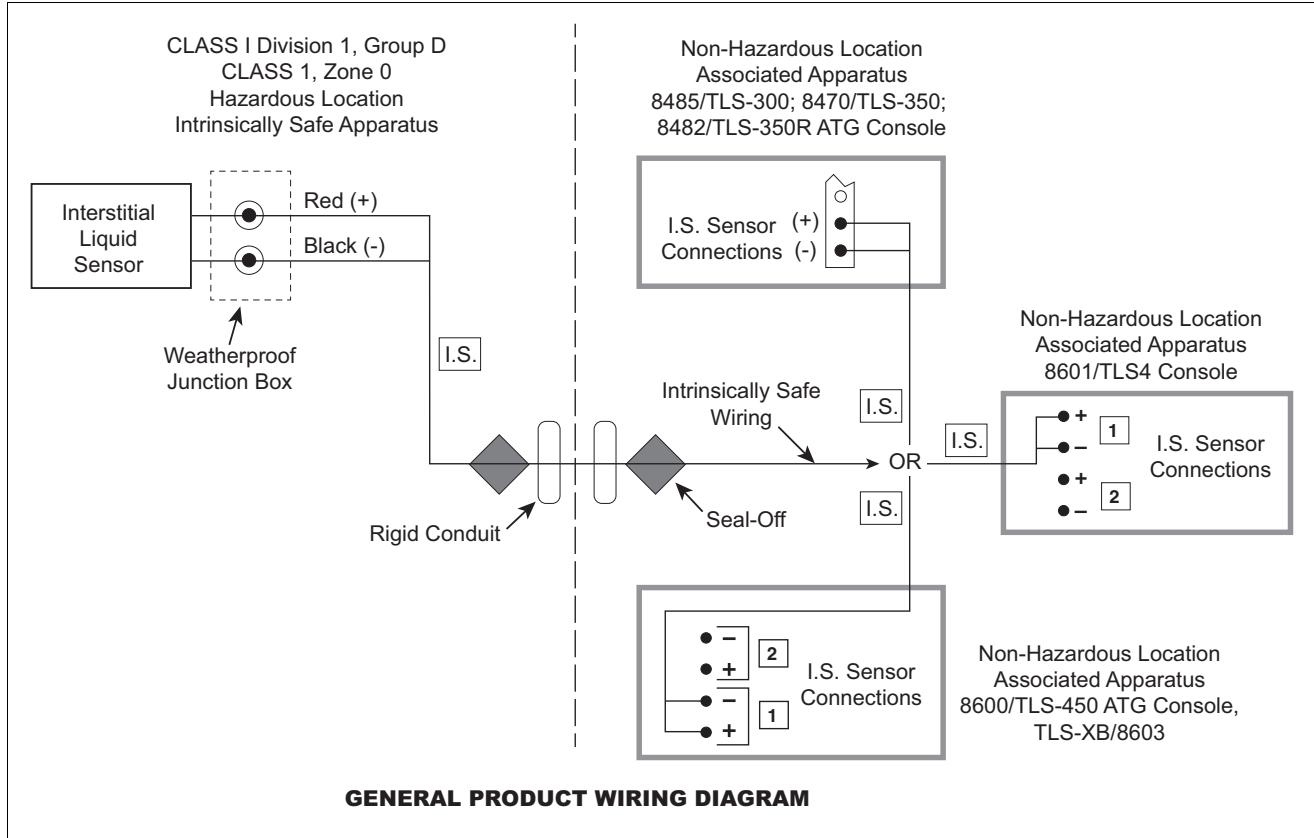





**Product Label Contents**

	I.S. CIRCUIT FOR HAZLOC SENSOR	
	F/N 7943X0-XXX	
CL I, DIV. 1, GP.D	S/N XXXXXX	
CL I, ZONE 0	-40°C ≤ Ta ≤ +60°C	
AEx ia IIA	MANUAL NO. 576013-616	
Ex ia IIA		
TC=T4		
SECURITE INTRINSEQUE	SIMPLE APPARATUS	

## Safety Warnings





To protect yourself and your equipment, observe the following warnings and important information:





<b>⚠ WARNING</b>	
    	<p>This product is to be installed and operated in the highly combustible environment of a gasoline storage tank where flammable liquids and explosive vapors may be present.</p> <p><b>FAILURE TO COMPLY WITH THE FOLLOWING WARNINGS AND SAFETY PRECAUTIONS COULD CAUSE DAMAGE TO PROPERTY, ENVIRONMENT, RESULTING IN SERIOUS INJURY OR DEATH.</b></p> <ol style="list-style-type: none"> <li>1. Read and follow all instructions in this manual, including all safety warnings to protect yourself and others from serious injury, explosion, or electrical shock.</li> <li>2. Comply with all applicable codes including: the National Electrical Code; federal, state, and local codes; and other applicable safety codes.</li> <li>3. To protect yourself and others from being struck by vehicles, block off your work area during installation or service.</li> <li>4. Do not alter or modify any component or substitute components in this kit.</li> <li>5. <b>Warning!</b> Substitution of components may impair intrinsic safety.</li> <li>6. Field wiring to the Sensor must not share a conduit with any non-intrinsically safe device's wiring.</li> <li>7. <b>Warning!</b> To prevent ignition of flammable or combustible atmospheres, disconnect power before servicing.</li> <li>8. Before installing or taking the unit into a hazardous area, earth the unit in a safe area to remove any static charge. Then immediately transport the unit to the installation site. Do not rub or clean the unit prior to installation. Cleaning is not required under normal service conditions. Do not rub or clean the unit after installation. If the unit is not fixed to a known earth point when installed, ensure that a separate earth connection is made to prevent the potential of a static discharge. When fitting or removing the unit, use of anti-static footwear or clothing is required.</li> <li>9. Materials used in the construction of this device do not contain, by mass, more than 10% in total of aluminum, magnesium, zirconium and titanium or 7.5% in total of magnesium, titanium and zirconium.</li> </ol>

**NOTE** Failure to install this product in accordance with its instructions and warnings will result in voiding of all warranties with this product.

## Safety Symbols

The following safety symbols may be used throughout this manual to alert you to important safety hazards and precautions.

	<p><b>EXPLOSIVE</b> Fuels and their vapors are extremely explosive if ignited.</p>		<p><b>FLAMMABLE</b> Fuels and their vapors are extremely flammable.</p>
	<p><b>TURN POWER OFF</b> Live power to a device creates a potential shock hazard. Turn Off power to the device and associated accessories when servicing the unit.</p>		<p><b>GLOVES</b> Wear gloves to protect hands from irritation or injury.</p>

 <p><b>USE SAFETY BARRICADES</b> Unauthorized people or vehicles in the work area are dangerous. Always use safety cones or barricades, safety tape, and your vehicle to block the work area.</p>	 <p><b>READ ALL RELATED MANUALS</b> Knowledge of all related procedures before you begin work is important. Read and understand all manuals thoroughly. If you do not understand a procedure, ask someone who does.</p>
 <p><b>WEAR EYE PROTECTION</b> Wear eye protection when working with pressurized fuel lines or epoxy sealant to avoid possible eye injury.</p>	 <p><b>INJURY</b> Careless or improper handling of materials can result in bodily injury.</p>

## Sensor Description

The Veeder-Root Interstitial Liquid Sensor detects the presence of liquid in the interstitial space of a double-wall tank. When liquid is detected, the sensor sends an alarm signal to the console. The console's visual and audible built-in alarm indicators immediately tell you where the problem is, so you can quickly take action to help prevent serious safety and environmental problems. The Interstitial Liquid Sensor can be used in the annulus of a tank with a sensor riser pipe of 2" I.D. or greater.

## COMPONENTS SHIPPED

Qty.	Description
1	Interstitial Steel Tank Sensor (as ordered)
1	Field wiring kit, P/N 330020-539
1	Installation Guide, P/N 576013-616

## MODELS

Sensor Form No.	Operating Temp.	Storage Temp.	Dimensions	Cable Length	Other
794380-333	-40°C to +60°C	-40°C to +75°C	3.275" high, 1.75" dia.	16 feet	Position Sensitive
794380-430			2.5" high, 1.5" dia.	16 feet	Alternate Fluids
794390-420				16 feet	
794390-460				30 feet	

## SENSOR STATES

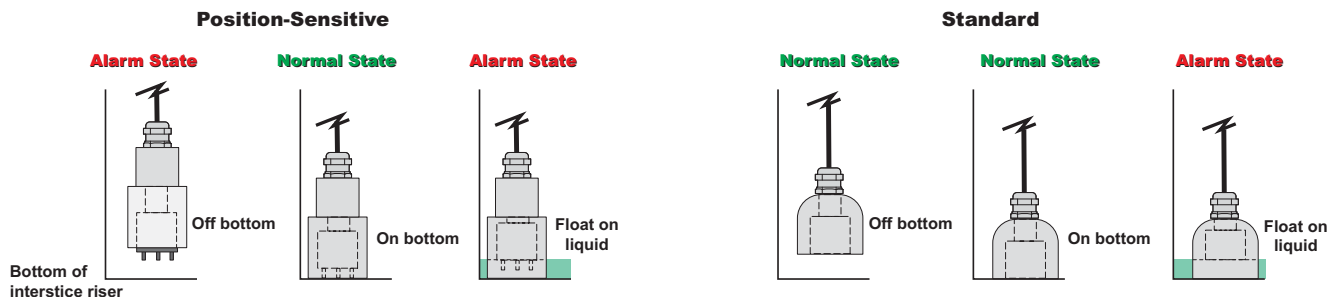

## Installation



1. Turn OFF power to the console.
2. Make sure no liquid is present in the annular space. Important! Do not install the sensor if any liquid is present in the annular space. Failure to comply will lead to an alarm.
3. To ensure proper operation of these sensors, they must rest on the bottom of the tank's interstitial riser. Lower the sensor into the riser until it rests on the bottom of the riser (see Figure 1).
4. Keeping the cable taut, secure the sensor in place by attaching a grip cord. Note: The sensor should not be suspended by the cable, but should rest on the bottom of the tank.
5. Secure the riser cap to the riser pipe.
6. Tighten the cable bushing nuts on the riser cap and junction box to ensure a water-tight seal at the cable entry.

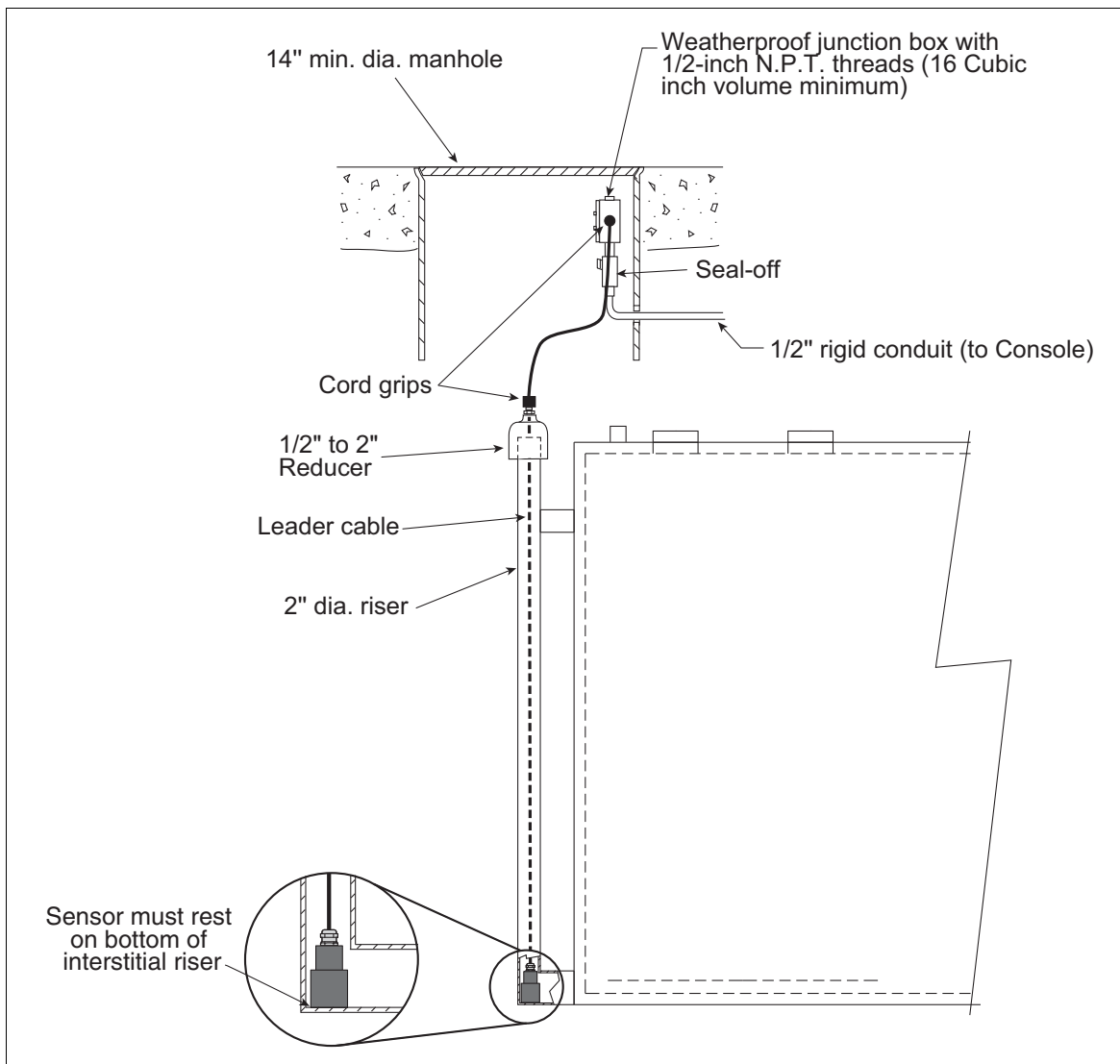

Figure 1. Example Sensor Installation - Steel Tank



- Using wire nuts, connect the two-wire sensor cable to the field wires in the sensor junction box (Figure 2). Seal wire nuts with epoxy sealant following the instructions in Figure 3.

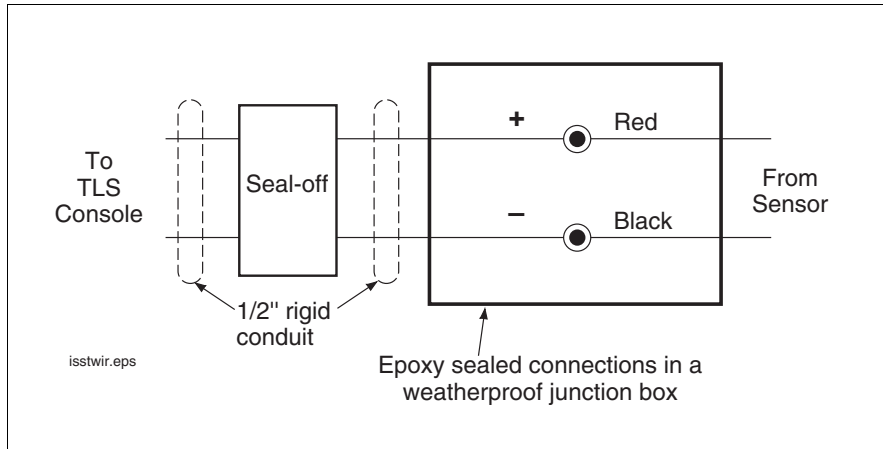

Figure 2. Sensor Field Wiring Diagram

**A**

**B**

**C**

**Instructions:**

NOTE: When temperature is below 50°F (10°C), keep resin in a warm place prior to mixing (e.g., in an inside pocket next to body).

- Open epoxy sealant package, and remove resin pak.
- Holding resin pak as shown in A, bend pak along long length.
- As shown in B, firmly squeeze the RED SIDE of the resin, forcing it through the center seal and into BLACK SIDE.
- Mix thoroughly to a uniform color by squeezing contents back and forth 25-30 times.
- Squeeze mixed, warm resin into one end of bag and cutoff other end.
- Slowly insert wiring connections into sealing pack until they fit snugly against the opposite end as shown in C.
- Twist open end of bag and use tie wrap to close it off and position the tie wrapped end up until the resin jells.

**CAUTION:** Epoxy sealant is irritating to eyes, respiratory system, and skin. Can cause allergic skin reaction. Contains: epoxy resin and Cycloaliphatic epoxy-carboxylate.

**Precautions:** Wear suitable protective clothing, gloves, eye, and face protection. Use only in well ventilated areas. Wash thoroughly before eating, drinking, or smoking.

consoleslepky2w.eps

Figure 3. Epoxy sealing example

