



Introduction

Purpose

This manual provides instructions to install the Boot Switch Kit (M14142K001) in Gasboy® 9800A/2600A/215A/7215A front-load model dispensers.

Table of Contents

| Topic | Page |
|---|------|
| Introduction | 1 |
| Important Safety Information | 3 |
| Installing Boot Switch Kit (M14142K001) | 5 |

Required Tools and Materials

Following tools and materials are required to install the Boot Switch Kit:

- Nut Driver
- Heat Gun
- Thread Lock

Parts List

Following table lists parts included in the Boot Switch Kit:

| Item | Description | Part Number | Quantity |
|------|----------------------------------|-------------|----------|
| 1 | Extension Spring | 064400 | 1 |
| 2 | Nozzle Boot Bearing | 064401 | 2 |
| 3 | Nozzle Bracket Lock Bushing | M14068B001 | 1 |
| 4 | Flat Washer (Spacer) | K65235-33 | 1 |
| 5 | Cotter Pin | K02124 | 1 |
| 6 | Reed Switch and Bracket Assembly | M14143A001 | 1 |
| 7 | Lever Shaft Assembly | M14144A001 | 1 |
| 8 | Magnet and Bracket Assembly | M14145A001 | 1 |

Figure 1 shows the components in the Boot Switch Kit.

Figure 1: Boot Switch Kit Components

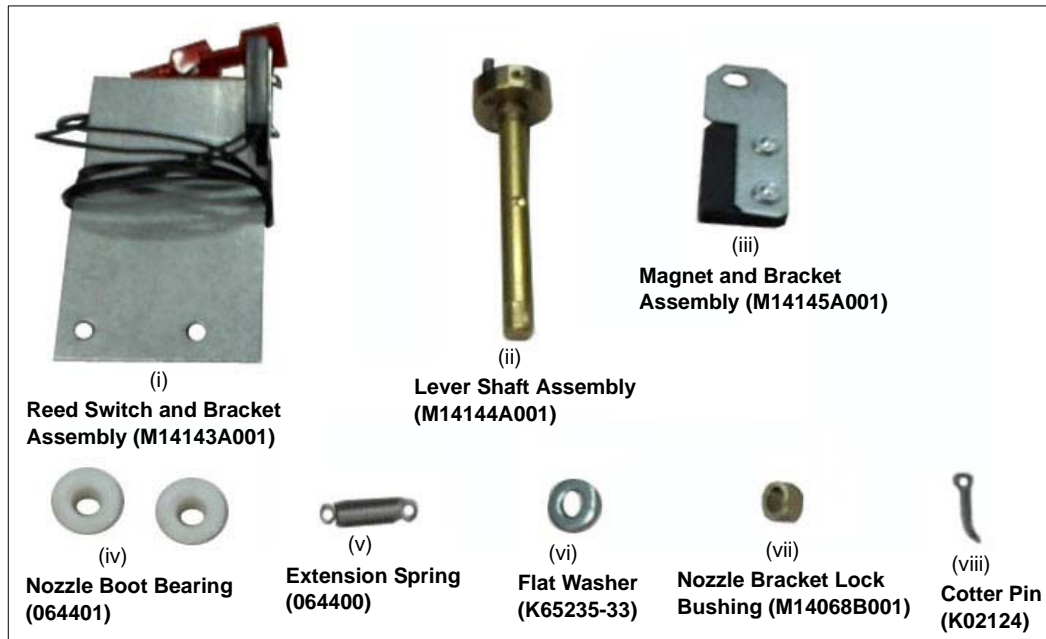

Related Documents

| Document Number | Title | GOLD SM Library |
|-----------------|-----------------------------------|--|
| MDE-4430 | Important Warnings and Safeguards | Gasboy [®] Safety and Warranty Docs |

Abbreviations and Acronyms

| Term | Description |
|------|--|
| ATC | Automatic Temperature Compensation |
| GOLD | Gilbarco [®] Online Documentation |
| I.S | Intrinsic Safety |
| OEM | Original Equipment Manufacturer |

Important Safety Information

Notes: 1) *Save this Important Safety Information section in a readily accessible location.*

2) *Although DEF is non-flammable, Diesel is flammable. Therefore, for DEF cabinets that are attached to Diesel dispensers, follow all the notes in this section that pertain to flammable fuels.*

This section introduces the hazards and safety precautions associated with installing, inspecting, maintaining or servicing this product. Before performing any task on this product, read this safety information and the applicable sections in this manual, where additional hazards and safety precautions for your task will be found. Fire, explosion, electrical shock or pressure release could occur and cause death or serious injury, if these safe service procedures are not followed.



Preliminary Precautions

You are working in a potentially dangerous environment of flammable fuels, vapors, and high voltage or pressures. Only trained or authorized individuals knowledgeable in the related procedures should install, inspect, maintain or service this equipment.

Emergency Total Electrical Shut-Off

The first and most important information you must know is how to stop all fuel flow to the pump/dispenser and island. Locate the switch or circuit breakers that shut off all power to all fueling equipment, dispensing devices, and Submerged Turbine Pumps (STPs).

⚠ WARNING

The EMERGENCY STOP, ALL STOP, and PUMP STOP buttons at the cashier's station WILL NOT shut off electrical power to the pump/dispenser. This means that even if you activate these stops, fuel may continue to flow uncontrolled.

You must use the TOTAL ELECTRICAL SHUT-OFF in the case of an emergency and not the console's ALL STOP and PUMP STOP or similar keys.

Total Electrical Shut-Off Before Access

Any procedure that requires access to electrical components or the electronics of the dispenser requires total electrical shut off of that unit. Understand the function and location of this switch or circuit breaker before inspecting, installing, maintaining, or servicing Gasboy equipment.

Evacuating, Barricading and Shutting Off

Any procedure that requires access to the pump/dispenser or STPs requires the following actions:



- An evacuation of all unauthorized persons and vehicles from the work area
- Use of safety tape, cones or barricades at the affected unit(s)
- A total electrical shut-off of the affected unit(s)

Read the Manual

Read, understand and follow this manual and any other labels or related materials supplied with this equipment. If you do not understand a procedure, call a Gasboy Authorized Service Contractor or call the Gasboy Service Center at 1-800-444-5529. It is imperative to your safety and the safety of others to understand the procedures before beginning work.

Follow the Regulations

Applicable information is available in National Fire Protection Association (NFPA) 30A; *Code for Motor Fuel Dispensing Facilities and Repair Garages*, NFPA 70; *National Electrical Code (NEC)*, Occupational Safety and Health Administration (OSHA) regulations and federal, state, and local codes. All these regulations must be followed. Failure to install, inspect, maintain or service this equipment in accordance with these codes, regulations and standards may lead to legal citations with penalties or affect the safe use and operation of the equipment.

Replacement Parts

Use only genuine Gasboy replacement parts and retrofit kits on your pump/dispenser. Using parts other than genuine Gasboy replacement parts could create a safety hazard and violate local regulations.

Safety Symbols and Warning Words

This section provides important information about warning symbols and boxes.

Alert Symbol



This safety alert symbol is used in this manual and on warning labels to alert you to a precaution which must be followed to prevent potential personal safety hazards. Obey safety directives that follow this symbol to avoid possible injury or death.

Signal Words

These signal words used in this manual and on warning labels tell you the seriousness of particular safety hazards. The precautions below must be followed to prevent death, injury or damage to the equipment:

- ⚠ DANGER:** Alerts you to a hazard or unsafe practice which will result in death or serious injury.
- ⚠ WARNING:** Alerts you to a hazard or unsafe practice that could result in death or serious injury.
- ⚠ CAUTION with Alert symbol:** Designates a hazard or unsafe practice which may result in minor injury.
- ⚠ CAUTION without Alert symbol:** Designates a hazard or unsafe practice which may result in property or equipment damage.

Working With Fuels and Electrical Energy

Prevent Explosions and Fires

Fuels and their vapors will explode or burn, if ignited. Spilled or leaking fuels cause vapors. Even filling customer tanks will cause potentially dangerous vapors in the vicinity of the dispenser or island.

DEF is non-flammable. Therefore, explosion and fire safety warnings do not apply to DEF lines.

Important Safety Information

No Open Fire



Open flames from matches, lighters, welding torches or other sources can ignite fuels and their vapors.

No Sparks - No Smoking



Sparks from starting vehicles, starting or using power tools, burning cigarettes, cigars or pipes can also ignite fuels and their vapors. Static electricity, including an electrostatic charge on your body, can cause a spark sufficient to ignite fuel vapors. Every time you get out of a vehicle, touch the metal of your vehicle, to discharge any electrostatic charge before you approach the dispenser island.

Working Alone

It is highly recommended that someone who is capable of rendering first aid be present during servicing. Familiarize yourself with Cardiopulmonary Resuscitation (CPR) methods, if you work with or around high voltages. This information is available from the American Red Cross. Always advise the station personnel about where you will be working, and caution them not to activate power while you are working on the equipment. Use the OSHA Lockout/Tagout procedures. If you are not familiar with this requirement, refer to this information in the service manual and OSHA documentation.

Working With Electricity Safely

Ensure that you use safe and established practices in working with electrical devices. Poorly wired devices may cause a fire, explosion or electrical shock. Ensure that grounding connections are properly made. Take care that sealing devices and compounds are in place. Ensure that you do not pinch wires when replacing covers. Follow OSHA Lockout/Tagout requirements. Station employees and service contractors need to understand and comply with this program completely to ensure safety while the equipment is down.

Hazardous Materials

Some materials present inside electronic enclosures may present a health hazard if not handled correctly. Ensure that you clean hands after handling equipment. Do not place any equipment in the mouth.

WARNING

The pump/dispenser contains a chemical known to the State of California to cause cancer.

WARNING

The pump/dispenser contains a chemical known to the State of California to cause birth defects or other reproductive harm.

In an Emergency

Inform Emergency Personnel

Compile the following information and inform emergency personnel:

- Location of accident (for example, address, front/back of building, and so on)
- Nature of accident (for example, possible heart attack, run over by car, burns, and so on)
- Age of victim (for example, baby, teenager, middle-age, elderly)
- Whether or not victim has received first aid (for example, stopped bleeding by pressure, and so on)
- Whether or not a victim has vomited (for example, if swallowed or inhaled something, and so on)

WARNING



Gasoline/DEF ingested may cause unconsciousness and burns to internal organs. Do not induce vomiting. Keep airway open. Oxygen may be needed at scene. Seek medical advice immediately.

WARNING

DEF generates ammonia gas at higher temperatures. When opening enclosed panels, allow the unit to air out to avoid breathing vapors. If respiratory difficulties develop, move victim away from source of exposure and into fresh air. If symptoms persist, seek medical attention.

WARNING



Gasoline inhaled may cause unconsciousness and burns to lips, mouth and lungs. Keep airway open. Seek medical advice immediately.

WARNING



Gasoline/DEF spilled in eyes may cause burns to eye tissue. Irrigate eyes with water for approximately 15 minutes. Seek medical advice immediately.

WARNING



Gasoline spilled on skin may cause burns. Wash area thoroughly with clear water. Seek medical advice immediately.

WARNING

DEF is mildly corrosive. Avoid contact with eyes, skin, and clothing. Ensure that eyewash stations and safety showers are close to the work location. Seek medical advice recommended treatment if DEF spills into eyes.

IMPORTANT: Oxygen may be needed at scene if gasoline has been ingested or inhaled. Seek medical advice immediately.

Lockout/Tagout

Lockout/Tagout covers servicing and maintenance of machines and equipment in which the unexpected energization or start-up of the machine(s) or equipment or release of stored energy could cause injury to employees or personnel. Lockout/Tagout applies to all mechanical, hydraulic, chemical or other energy, but does not cover electrical hazards. Subpart S of 29 CFR Part 1910 - Electrical Hazards, 29 CFR Part 1910.333 contains specific Lockout/Tagout provision for electrical hazards.

Installing Boot Switch Kit (M14142K001)

Before installing, read and understand the warnings and safeguard precautions for the remote dispensers and pumps provided in *MDE-4430 Important Warnings and Safeguards*.

Removing Mercury Switch

Note: Mercury switch that may be currently installed in the pump/dispenser is no longer available from the Original Equipment Manufacturer (OEM) supplier (environmental concerns).

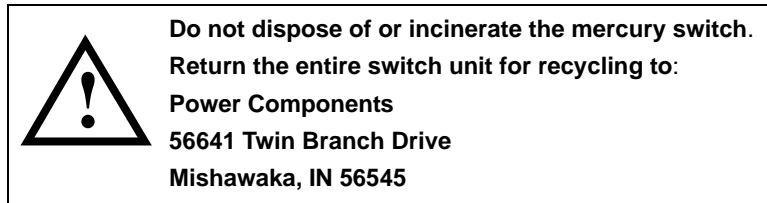
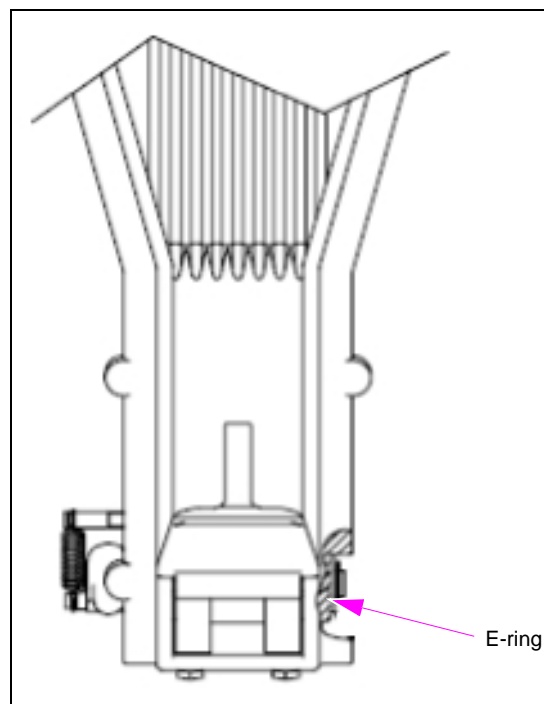

Figure 2: Mercury Switch Configuration (No Longer Available)



The current kit uses a magnet/reed switch combination. The magnet/reed switch is preassembled but it requires some further assembly.

Note: The magnet/reed switch is not as compact as the mercury switch, so it has to be placed on the right side of the boot instead of the left side where the mercury switch is located.

To remove the mercury switch, proceed as follows:

- 1 Remove the door from the pump/dispenser.
- 2 Disconnect the wire plugs (fastons) that connect the mercury switch to the Intrinsic Safety (I.S) barrier.
- 3 Remove the set screw. It may be necessary to loosen the thread lock on the set screw using a heat gun. If this is necessary, follow steps 4 and 5, which describe removing the boot assembly so it can be taken to a safe distance from the pump/dispenser before using the heat gun. Otherwise skip to step 6.

Figure 3: Move Lift Handle to ON (Up) Position to Expose Set Screw

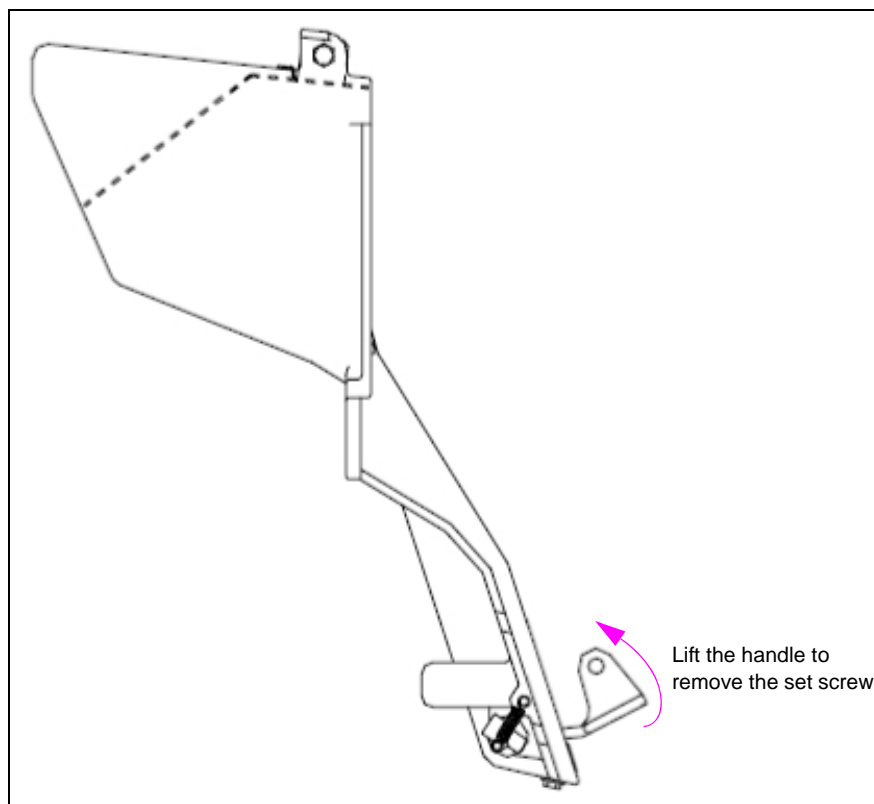

- 4 Remove the two bolts that attach the nozzle boot assembly to the pump frame. Take the boot to a safe distance from the pump.
- 5 Heat the set screw with a heat gun for about 30 seconds, which should allow for easy removal of the set screw.
- 6 Remove the extension spring from the left side of the boot. Remove the e-ring (clip) from the end of the mercury switch and slide the mercury switch out.

Removing the mercury switch from the pump/dispenser is now complete.

Installing Magnet/Reed Switch

To install the magnet/reed switch, proceed as follows:

- 1 Remove screws from the bottom of the boot that holds the locking plate using a nut driver.
Note: Retain the screws for later assembly.

Figure 4: Removing Screws from Boot Bottom

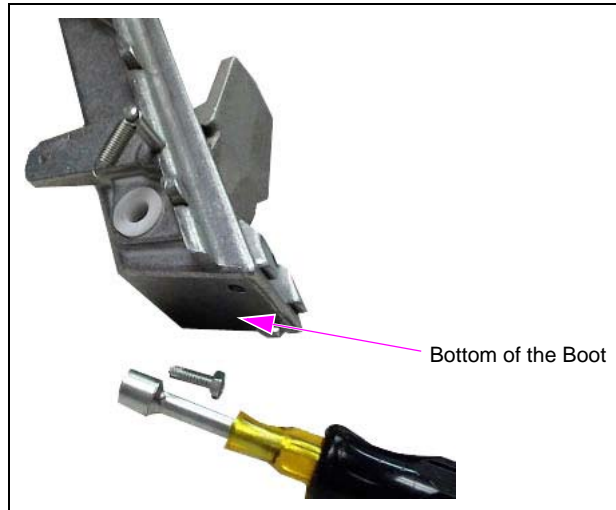

- 2 Place the Reed Switch and Bracket Assembly (M14143A001) to the bottom of the boot, and then replace the screws to secure it and the locking plate.
Note: Use the screws removed in step 1.

Figure 5: Installing Reed Switch Bracket

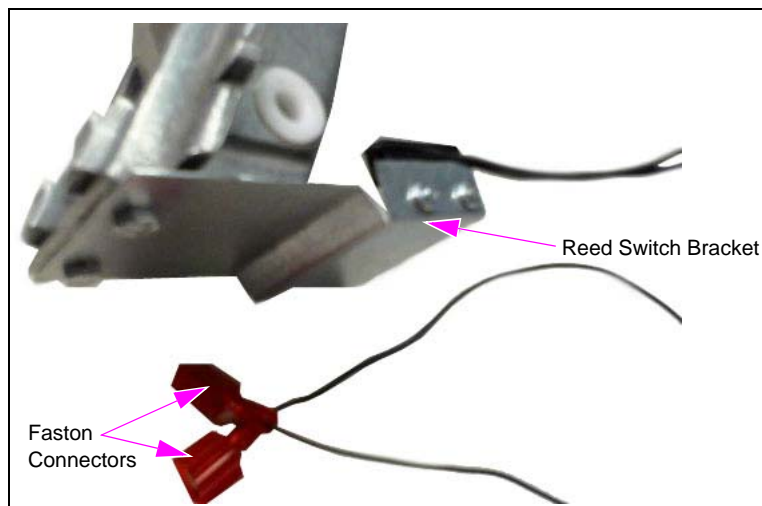

- 3 Install the lever shaft. Ensure that the set screw cavity and roll pin point are in the same direction. This will help with alignment.

Figure 6: Installing Lever Shaft

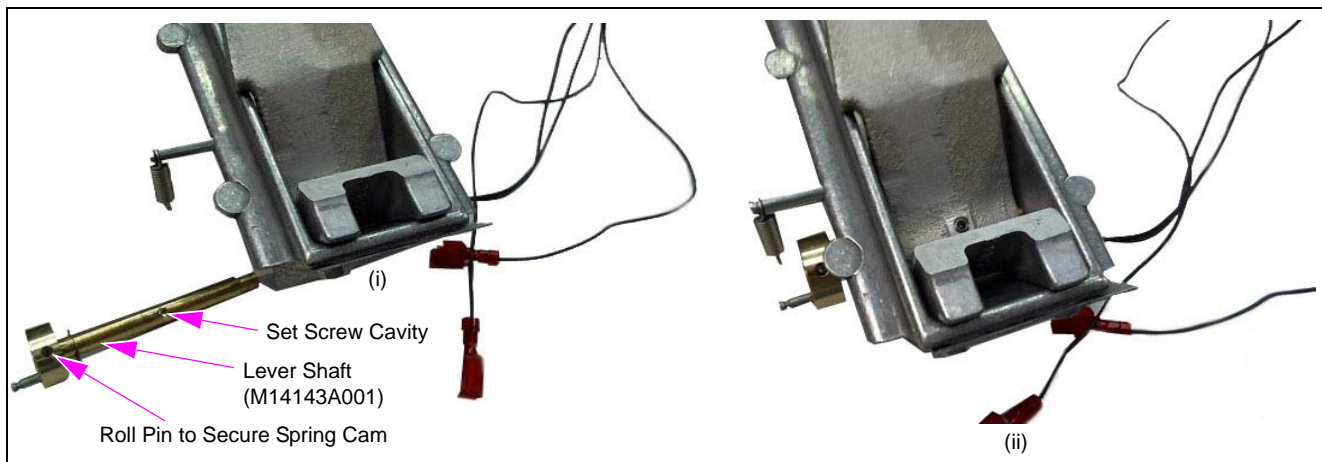

- 4 Install the Spacer Washer (K65235-33), Magnet Bracket Assembly (M14145A001), Nozzle Bracket Lock Bushing (M14068B001), and Cotter Pin (K02124) to the lever shaft.

Figure 7: Installing Spacer Washer

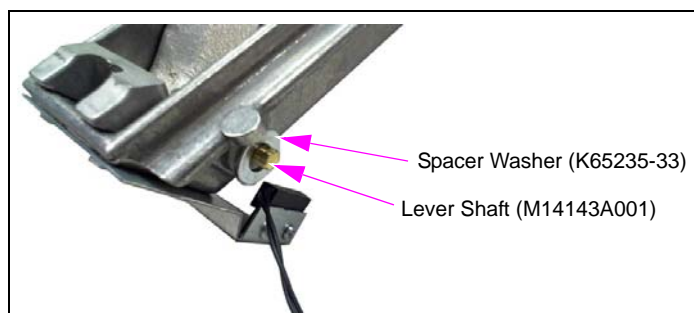
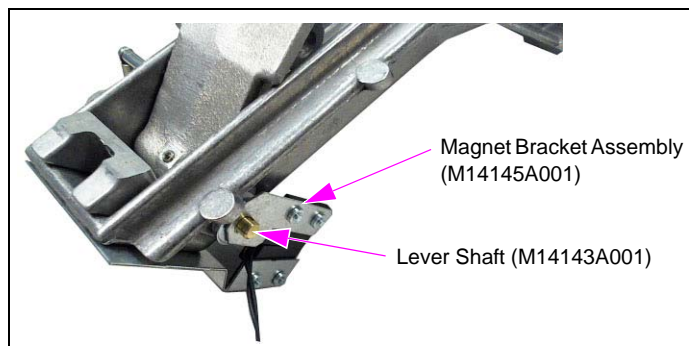
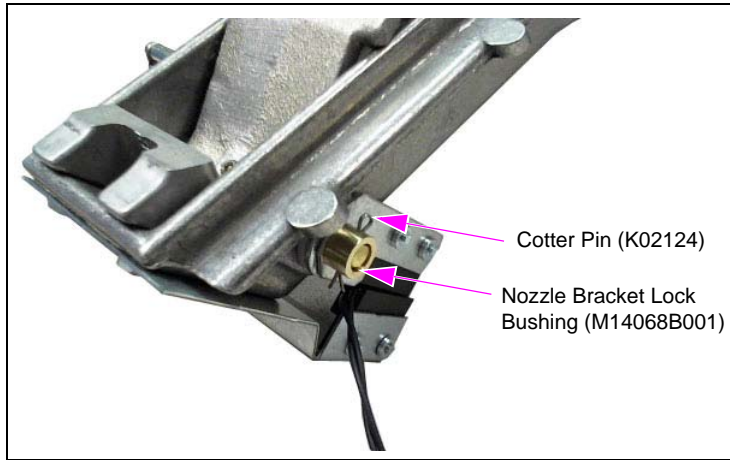

Figure 8: Installing Magnet Bracket Assembly



Note: The shaft has a D shape end that matches a D shaped hole in the magnet bracket assembly. These D shapes are supposed to be tight, so carefully and gently wriggle the bracket onto the shaft. When the magnet bracket assembly is fully onto the shaft, the lock bushing is in and aligned, the cotter pin should easily go into place. Ensure that one of the cotter pin legs is bent to secure it in place (see [Figure 9](#) on [page 9](#)).

Figure 9: Installing Nozzle Bracket Lock Bushing



- 5 Install the extension spring and secure the lift arm set screw.

Figure 10: Installing Extension Spring

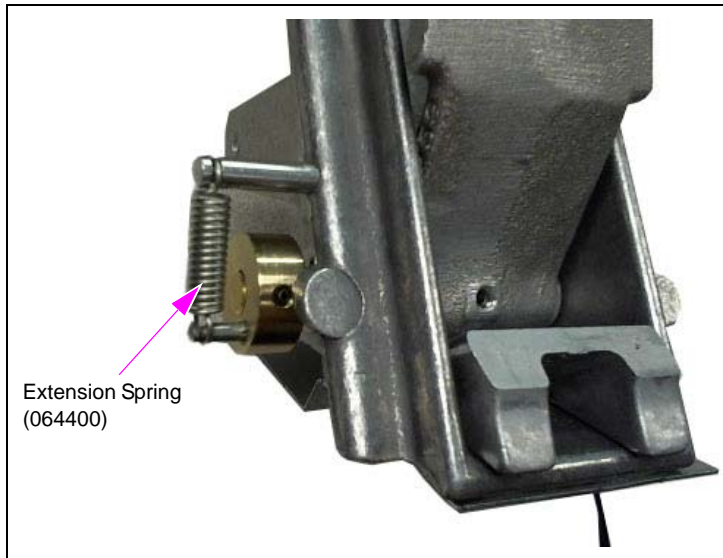

- Hook the spring in place. With the boot handle lifted up, the set screw cavity on the shaft should align with the set screw. Ensure that the set screw cavity and roll pin point are in the same direction (see [Figure 6](#) on [page 8](#)). It is important that the set screw engage the set screw cavity on the shaft. To ensure that it stays engaged, apply a light coat of thread lock to the set screw threads.

[Figure 11](#) shows the completed magnet/reed switch installation.

Figure 11: Magnet/Reed Switch

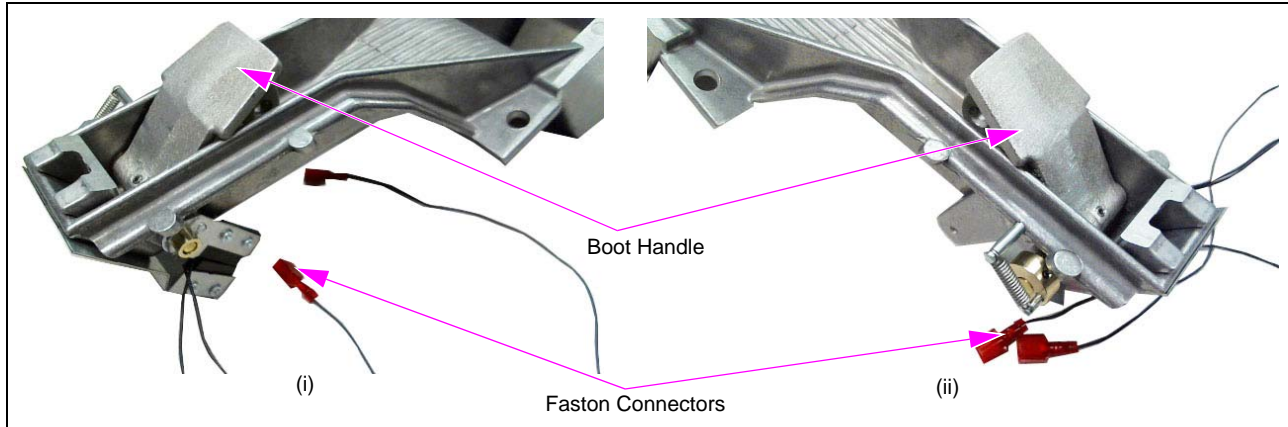

- Reinstall the boot to the pump/dispenser. Plug up the faston connectors.

Installing the Boot Switch Kit is now complete.

Gasboy® are registered trademarks of Gasboy International. Gilbarco® is a the registered trademark of Gilbarco Inc. GOLDSM is a service mark of Gilbarco Inc.

