



Model 1200 Rotary Pumps

Repair Kit 032885

MDE-4432
(formerly 017850)

Company Programs and Documentation

All Gasboy computer programs (including software on diskettes and within memory chips) and documentation are copyrighted by, and shall remain the property of, Gasboy. Such computer programs and documents may also contain trade secret information. The duplication, disclosure, modification, or unauthorized use of computer programs or documentation is strictly prohibited, unless otherwise licensed by Gasboy.

FCC Warning

This equipment has been tested and found to comply with the limits for a Class A digital device pursuant to Part 15 of the FCC Rules. These limits are designed to provide reasonable protection against harmful interference when the equipment is operated in a commercial environment. This equipment generates, uses, and can radiate radio frequency energy, and if not installed and used in accordance with the instruction manual, may cause harmful interference to radio communications. Operation of this equipment in a residential area is likely to cause harmful interference in which case the user will be required to correct the interference at his own expense. Changes or modifications not expressly approved by the manufacturer could void the user's authority to operate this equipment.

Approvals

Gasboy, Greensboro, is an ISO 9001:2000 registered facility.

Underwriters Laboratories:

New York
City:

California Air Resources Board (CARB):

U.L. File#	Products listed with U.L.	NYFD of A #	Product	Executive Order #	Product
MH4314	All dispensers and self-contained pumping units	4823	9100A, 9140A, 9152A, 9153A, 9800A, 9840A, 9850A, 9852A, 9853A, 9140	G-70-52-AM G-70-150-AE	Balance Vapor Recovery VaporVac
MH6418	Power operated Transfer Pump Models 25, 25C, 26, 27, 28, 72, 72S, 72SP, 72X, 73 and 1820	4997	9822A, 9823A		
MH7404	Hand operated Transfer Pump Models 1230 Series, 1243 Series, 1520 and 1720 Series	5046	9100Q, 9140Q, 9152Q, 9153Q, 9800Q, 9840Q, 9852Q, 9853Q		
MH10581	Key control unit, Model GKE-B Series Card reader terminals, Models 1000, 1000P Site controller, Model 2000S CFN Series Data entry terminals, Model TPK-900 Series Fuel Point Reader System				

NCWM – Certificate of Compliance

Gasboy pumps and dispensers are evaluated by the National Conference of Weights and Measures (NCWM) under the National Type Evaluation Program (NTEP).

NCWM has issued the following Certificates of Compliance (COC):

COC#	Product	Model #	COC #	Product	Model #	COC #	Product	Model #
95-179A2	Dispenser	9100 Retail 8700 Series, 9700 Series	91-019A2	Dispenser	9100 Commercial Series			
95-136A5	Dispenser	9800 Series	91-0573A3	Dispenser	1000 Series 2000-CFN Series			

Patents

Gasboy products are manufactured or sold under one or more of the following U.S. patents:

Dispensers

5,257,720

Point of Sale/Back Office Equipment

D335,673

Trademarks

Non-registered trademarks

Atlas™
Consola™
Infinity™

Registered trademarks

ASTRA®
Fuel Point®
Gasboy®
Keytrol®
Slimline®

Additional U.S. and foreign trademarks pending.

Other brand or product names shown may be trademarks or registered trademarks of their respective holders.

Additional U.S. and foreign patents pending.



IMPORTANT WARNINGS AND SAFEGUARDS

Gasoline and petroleum products are flammable. To avoid injury or death to persons or damage to equipment or property, follow these listed warnings and other warnings and precautions outlined in this manual when installing, using, or working around this equipment. Check with Gasboy Technical Services for compatibility of liquids with pump materials.

TURN OFF AND LOCK OUT ALL POWER TO PUMP BEFORE PERFORMING SERVICE, MAINTENANCE OR IN THE EVENT OF A FUEL SPILL.

All products must be installed by a qualified installer and used in conformance with all building, fire, and environmental codes and other safety requirements applicable to its installation and use, including, but not limited to, NFPA 30, NFPA 30A, NFPA 395 & NFPA 70. A qualified installer is familiar with fuel systems installations under the above stated building, fire, and environmental codes and other safety requirements for the particular type of installation.

This product is only part of a fuel dispensing system and additional equipment and accessories, such as, but not limited to, breakaway connectors, shear valves, pressure regulators, flow limiters, and other safety devices may be necessary to meet the applicable codes.

For maximum safety, we recommend that all employees be trained as to the location and procedure for turning off power to the entire system. Instructions regarding proper operation of the equipment along with the appropriate safety warnings should be posted in plain view at the fuel island.

Before performing service or maintenance (including changing of fuel filters or strainers) or in the event of a fuel spill, turn off and lock out all power to the system. In battery-powered pumps, disconnect power source. In submersible pump applications, turn off and lock out power at the master panel and close any impact valves to the submersible pump and any other dispensers which use that submersible pump. AC power can feed back into a shut-off dispenser when dispensers share a common submersible pump or starter relay. Also block islands so no vehicles can pull up to the dispenser when performing maintenance on the dispenser.

DO NOT use Teflon tape for any pipe threads in the product.

DO NOT use consumer pumps for pumping fuel or additives into aircraft.

DO NOT use commercial pumps for direct fueling of aircraft without filters and separators necessary to ensure product purity.

DO NOT use where sanitary design is required (for food products for human consumption) or with water-based liquids.

DO NOT smoke near the pump or when using the pump.

DO NOT use near open flame or electrical equipment which may ignite fumes.

DO NOT permit the dispensing of gasoline or other petroleum products into a vehicle with its motor running.

DO NOT permit the dispensing of gasoline or other petroleum products into unapproved containers or into approved containers in or on vehicles including trucks. All containers must be filled on the ground to prevent static discharge. Always use Approved and Listed hoses and nozzles with electric pumps and dispensers.

DO NOT block open the nozzle in any manner. Nozzles shall conform to UL and NFPA code requirements for attended or unattended service.

DO ensure that the pump is equipped with proper filters based on the product being dispensed and its intended use.

DO wear safety goggles and protective clothes when dispensing any liquid which may be potentially harmful or hazardous.

DO keep all parts of body and loose clothing clear of belts, pulleys, and other exposed moving parts at all times.

DO require washing and changing of clothes if fuel is spilled on a person or his/her clothing. Keep away from open flames, sparks, or people smoking.

DO provide a receptacle for catching product from pump/meter when servicing.

DO clean up product spills on the driveway. Turn off and lock out all power prior to cleanup.

DO ensure pump is properly grounded.

DO ensure hose is compatible with fluid being dispensed.

DO inspect hose, nozzle, and pump on a regular basis for wear, damage, or other conditions which may create a safety or environmental hazard.

DO make sure all pipe threads are properly cut and the inside reamed to remove burrs. Use UL classified gasoline-resisting compound on all joints of gasoline handling piping. Sealing compound must also be resistant to Gasohol (Ethanol and Methanol). Use gasoline-resistant pipe compound on male threads only; ***pipe compound used on female threads can be squeezed into the supply line where it can enter the product stream and become lodged in the pump or meter.***

DO ensure that junction box covers are in place and properly tightened. Mating surfaces between the box and cover must be free of dirt, nicks, and scratches. Properly plug all unused entries into the junction box.

REPAIR KIT 032885 FOR MODELS 1200 ROTARY PUMPS

This sheet lists the contents of your repair kit and shows the part locations.

Contents of the 032885 Repair Kit

Item	Part No.	Description
1	026995	Check Valve Gasket
2	C04033	Screw, 10-32 X 5/16 Pan Hd
3	054160	Shaft Seal
4	048995	O-Ring, 11/16 x 7/8 Buna-N
5	066670	Check Valve Assembly
A	*052990	Screw
B	*067315	Washer
C	*024341	Valve Disc
D	*012760	Check Valve Body
6	027355	Gasket Strainer Cover
7	058105	Spring-Vane
8	026830	Gasket (See Note)
9	067015	Vane, 1230
10	042865	Guide Pin
11	049011	O-Ring (Not Shown)

* Indicates sub-part.

NOTE: Item 8, 026830 Gasket was replaced with Item 11 O-Ring. All pumps with serial numbers higher than 1237594 should use the O-Ring.

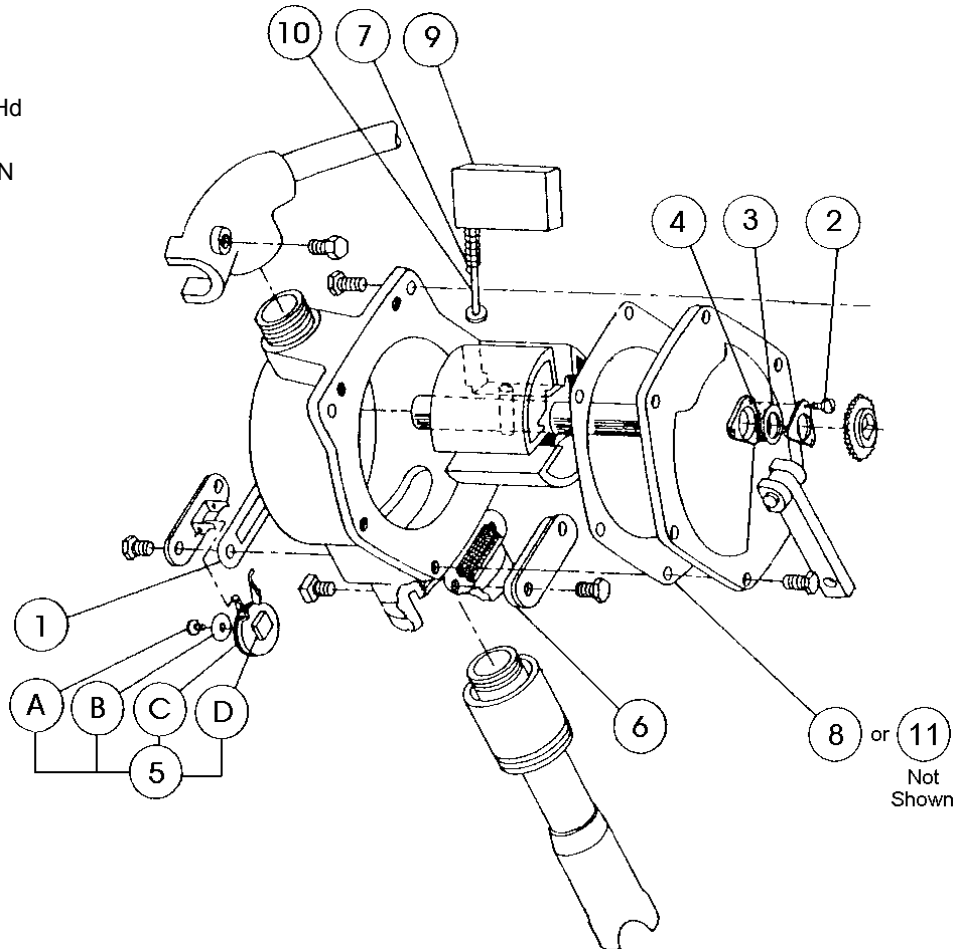



GASBOY WARRANTY POLICY STATEMENT

(Limited Warranty) New Product WARRANTY

GASBOY GUARANTEES NEW SERVICE STATION EQUIPMENT MANUFACTURED BY GASBOY IN ACCORDANCE WITH THE PROVISIONS STATED BELOW:

Gasboy will repair or replace parts and equipment found to be defective in materials or workmanship during the warranty period, subject to the following:

- Labor and travel costs incurred by the Authorized Service Contractor (ASC) while servicing Gasboy equipment are included, unless excepted, and will be paid at previously contracted rates to the qualified ASC.
- Warranty services must be performed by the nearest Authorized Service Contractor qualified to perform service on the defective equipment.
- Gasboy will supply new or rebuilt parts to replace parts, which are found to be defective within the warranty period. Parts returned to Gasboy must be shipped with transportation charges paid and will be replaced with parts with transportation charges prepaid by Gasboy.
- New Equipment installations must be registered with the Gasboy Call Center within 24 hours of installation to receive full warranty benefits; otherwise, the warranty period commences at the date of invoice.
- Warranty service response time is 24 hours from time service is requested, Monday through Friday (8:00 am until 5:00 pm), excluding weekends. Emergency warranty response time is on-site within 4 hours. Hazardous warranty response time is on-site within one hour. Priority situations, emergency and hazardous, include imminent release of hazardous of dangerous materials, situations with imminent danger to life or property, and a complete site-down situation or 50 percent or more of the fuel dispensing capacity for any one product is inoperative. Overtime will be paid for priority situations only occurring outside routine warranty service hours.
- Warranty repair requiring rented equipment, overtime premium, lodging or charter travel must be approved in advance of service expenditure by the Gasboy Warranty Administration Department.

Commercial Pumps and Dispensers, Full -Cabinet Consumer Pumps

Commercial Pumps and Dispensers, Full-Cabinet Consumer Pumps are warranted against defects in material and workmanship for one year from date of installation or 24 months from date of original invoice, whichever occurs first. Warranty coverage includes parts and labor.

Exclusions: This warranty excludes hose breakaways, nozzles, hoses and fittings, nozzle-end swivels, retriever cables, graphics materials specified by the customer, fuel filters, belts adjustments, meter calibration, fluorescent lamps, vapor recovery testing and balance system piping, customer-specified items manufactured by others, and customer requested reprogramming of equipment. Some of these excluded items may be warranted by their manufacturer, and warranty claims in connection with these items should be presented directly to the manufacturer.

Small Transfer Pumps, Meters, Pressure Regulators

Small Transfer Pumps, Meters and Pressure Regulators are warranted against defects in material and workmanship for 24 months from date of installation or 30 months from date of original invoice, whichever occurs first. Non-registered equipment warranty will default to invoice date. The warranty covers parts only. Excepting the Model 2020 Hand Pump, which has a 90-day part warranty from date of original invoice.

New Spare Parts

All new spare parts or warranted replacement parts are warranted against defects in material and workmanship for one year from date of original invoice. The warranty covers parts only.

Keytrol

The Keytrol is warranted against defects in material and workmanship for one year from date of installation or 24 months from date of original invoice, whichever occurs first. Warranty coverage includes parts and labor

Fuel Management Systems

CFN/Profit Point, Series 1000/FleetKey, TopKAT, and factory installed Fuel Point Reader are warranted against defects in material and workmanship for one year from date of installation or 24 months from date of original invoice, whichever occurs first. Warranty coverage includes parts and labor.

Standalone and Retrofit Fuel Point Readers, and Fuel Point-vehicle and dispenser components are warranted against defects in material and workmanship for one year from date of installation or 24 months from date of original invoice, whichever occurs first. The warranty covers parts only.

The warranty for field installed/retrofitted Fuel Point Readers is non-transferable. The removal and installation of such components into another pump/dispenser will void the warranty.

Fuel Management Systems

Peripherals (Modems, CRT's, Flat Screen, Scanner, PIN Pad, Customer Display,) are warranted against defects in material and workmanship for one year from date of installation or 24 months from date of original invoice, whichever occurs first. The warranty covers parts and labor.

Printers (Logger, Receipt, etc.) are warranted against defects in material and workmanship for 90 days from date of installation or 180 days from date of original invoice. The warranty coverage is parts and labor.

Peripherals (Encoders and Embossers) are warranted against defects in material and workmanship for six months from date of original invoice. The warranty covers parts only.

General Exclusions

1. Problems caused by faulty installation are not covered by this warranty. This warranty applies only if equipment has been installed and used in accordance with Gasboy Installation, Operating and Service Instructions. Problems caused by improper maintenance of equipment are not covered by this warranty.
2. Use of service personnel other than qualified Gasboy service providers without prior approval of the Warranty Administration Department will void payment of the warranty claim in question.
3. Damage suffered by Gasboy's equipment resulting from shipping, accident, power surges, neglect, misuse, act of Nature, or abuse is not covered by this warranty.
4. Use of non-Gasboy replacement parts, defects caused by the unauthorized addition of non-Gasboy items to Gasboy equipment or by the unauthorized alteration of Gasboy equipment voids this warranty.
5. THIS WARRANTY DOES NOT COVER ANY INDIRECT DAMAGES OR LOSS OF PRODUCT OR REVENUE. Repair or replacement of the defective part or component under the terms of this warranty is the EXCLUSIVE REMEDY. Gasboy is not liable for incidental, consequential or indirect damages or loss, including without limitation personal injury, death, property damage, environmental damages, product damages, loss of product, or loss of revenue or profits. Gasboy is not liable for any claims or lawsuits against the customer.
6. This warranty does not cover any pump or dispenser components in contact with fuels containing more than 5% methanol or 10% ethanol or 15% MTBE by Volume. This warranty does not cover any component(s) exposed to M85/E85 fuel or other alcohol rich fuel.

THE WARRANTY CONTAINED HEREIN IS EXCLUSIVE AND THERE ARE NO OTHER EXPRESSED, IMPLIED OR STATUTORY WARRANTIES. WARRANTIES OF MERCHANTABILITY OR FITNESS FOR A PARTICULAR PURPOSE ARE EXPRESSLY EXCLUDED.

GASBOY • Warranty Department F-43 • 7300 W. Friendly Ave., P.O. Box 22087 • Greensboro, NC 27420 • Phone 1-800-444-5529 • Fax: 336-547-5393