

Pump and Dispenser

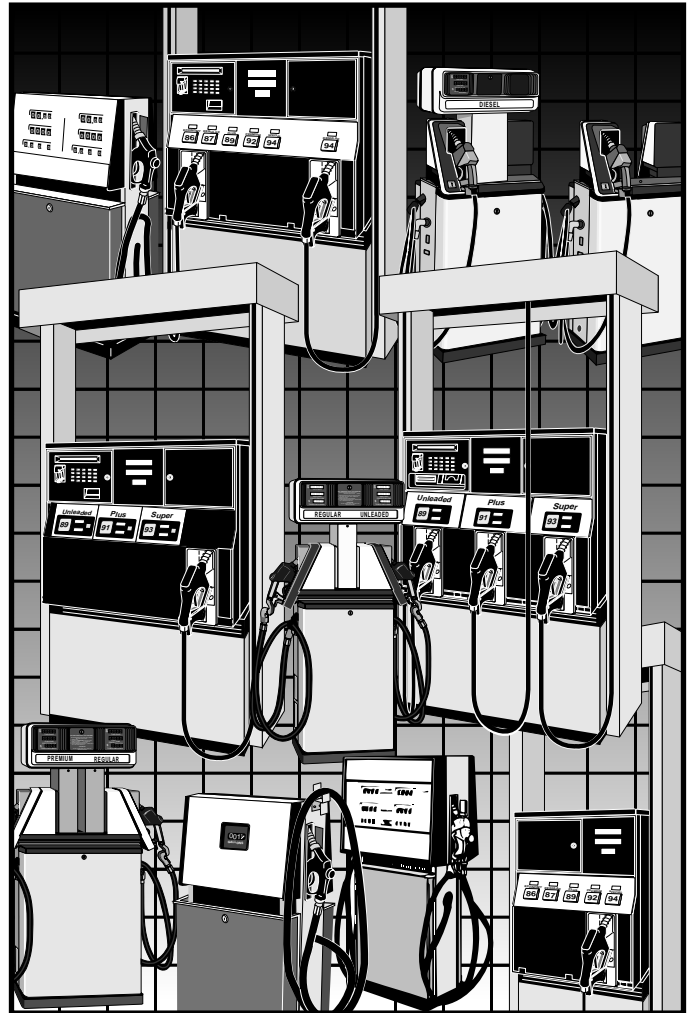

Installation Manual

Please see MDE-2833 for Site Prep Information.

Computer Programs

All Gilbarco computer programs (including software on diskettes and within memory chips) are copyrighted by, and shall remain the property of, Gilbarco Inc. Such computer programs may also contain trade secret information. The duplication, disclosure, modification, or unauthorized use of computer programs is strictly prohibited, unless otherwise licensed by Gilbarco.

FCC Warning

This equipment has been tested and found to comply with the limits for a Class A digital device pursuant to Part 15 of the FCC Rules. These limits are designed to provide reasonable protection against harmful interference when the equipment is operated in a commercial environment. This equipment generates, uses, and can radiate radio frequency energy, and if not installed and used in accordance with the instruction manual, may cause harmful interference to radio communications. Operation of this equipment in a residential area is likely to cause harmful interference in which case the user will be required to correct the interference at his own expense. Changes or modifications not expressly approved by the manufacturer could void the user's authority to operate this equipment.

Approvals

Underwriters Laboratories:

Gilbarco pumps and dispensers that bear the U.L. listing mark are listed under the U.L. file number MH1941.

National Quality Assurance:

Gilbarco is an ISO9001/BS5750 Part 1/EN29001 registered company, certificate number 5119.

Weights and Measures:

Gilbarco pumps and dispensers are evaluated by the National Institute of Standards and Technology (NIST) under the National Type Evaluation Program (NTEP). NIST has issued Certificates of Conformance (COC) for the following:

Model	COC#	Model	COC#
The Advantage Series	90-115-A4	Salesmaker Pro Blender: AB	78-099
MPD-3 Series: AE, AL, AP, AU	87-077A2	Salesmaker Series: AM	88-129
MPD-2 Series: AK	87-077A2	Trimline Series	91-088
MPD-1 Series: AF, AG, AN, AR	89-019A1	Legacy Series	94-027
H111B Series: AC	88-226A3		

California Air Resources Board (CARB):

The Executive Order for vapor recovery balance system G-70-52
The Executive Order for VaporVac G-70-150-AB
The Gilbarco approval for The Advantage motor fuel dispensers is on attachment "A".

New York City:

The Advantage® Series N.Y.C.F.D. COC #4805 (Refer to MDE-3197 NYC Requirements for approval)
The Legacy™ Series N.Y.C.F.D. COC #4879 (Refer to MDE-3197 NYC Requirements for approval)

Permissions:

Gilbarco has been given permission by OPW and ASCO to use their illustrations.

Patents

Gilbarco products are manufactured or sold under one or more of the following U.S. patents.

D.316,471	4,566,504	4,687,033	4,728,788	4,799,940	4,876,653	4,890,210	4,913,813
4,938,251	4,939,730	4,986,445	5,013,434	5,029,100	5,040,577	5,083,846	5,098,179
5,099,403	5,110,010	5,134,548	5,156,199	5,269,353	5,325,706	5,345,979	5,355,915

Canada Patented 1990 No. 1,276,917

Additional U.S. and foreign patents pending.

Trademarks

The following are trademarks of Gilbarco Inc.:

The Advantage® Series	MPD®	Proportional Flow Control Valve™	Super-Hi™	VaporVac®
G-SITE™	MPD® Pro Blender™	Salesmaker™	Trimline®	Highline™
MPD® Precision Blender™	Salesmaker Pro Blender™	Ultra-Hi™	The Legacy™ Series	

Copyrights

© 1995 Gilbarco Inc. All Rights Reserved

Memberships

Gilbarco is a member of the Petroleum Equipment Institute.

This document is subject to change without notice.
For information regarding Gilbarco Literature
call 910-547-5661.

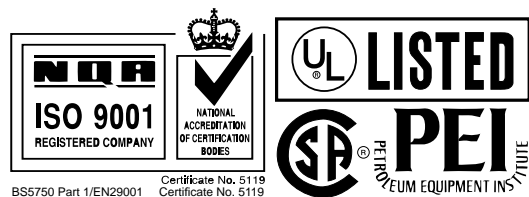

Salesmaker™ Series (High-Hose)

MDE-2530-41 Salesmaker™-2H and 4A Pumps/Dispensers
MDE-2530-43 Salesmaker Pro Blender™ Dispensers

MPD® Series (High-Hose)

MDE-2530-51 MPD®-1/3 and MPD Fixed Blender Dispensers
MDE-2530-53 MPD Pro Blender™ Dispensers
MDE-2530-55 MPD Precision Blender™ Dispensers

Remanufactured Models

MDE-2530-61 MPD-2/C Dispensers (with non-modular electronics)
MDE-2530-62 Highline Pumps/Dispensers (with non-modular electronics)
MDE-2530-63 MPD-1 Dispensers (with non-modular electronics)
MDE-2530-64 MPD-A3 Dispensers (with non-modular electronics)
MDE-2530-65 Salesmaker-4 Pumps/Dispensers (with non-modular electronics)

Glossary Terms

STP

Submerged turbine pump

Pump

Uses self-contained pumping unit and motor to move fuel from storage tank

Dispenser

Uses STP in storage tank to move fuel from storage tank

High Hose

Pumps/dispensers with hoses that connect overhead

Low Hose

Pumps/dispensers with hoses that connect at hydraulics level

Master/Satellite

Master dispensers are teamed with satellites for rapid fueling of trucks with saddle tanks. The master unit meters and computes product flow for both units. The satellite is a dispenser without the electronics module.

Listed

Products that bear the authorized Listing Mark of U.L. as the manufacturer's declaration that the product complies with U.L.'s requirements in accordance with the terms of U.L.'s Listing and Follow-Up Service agreement.

Classifying Hazardous Locations

Any activity that can cause an explosion (e.g. smoking, drilling, etc.) must be done well outside the vapor area.

The following diagrams are based on NFPA 30A, section 6 and NFPA 70, section 514.

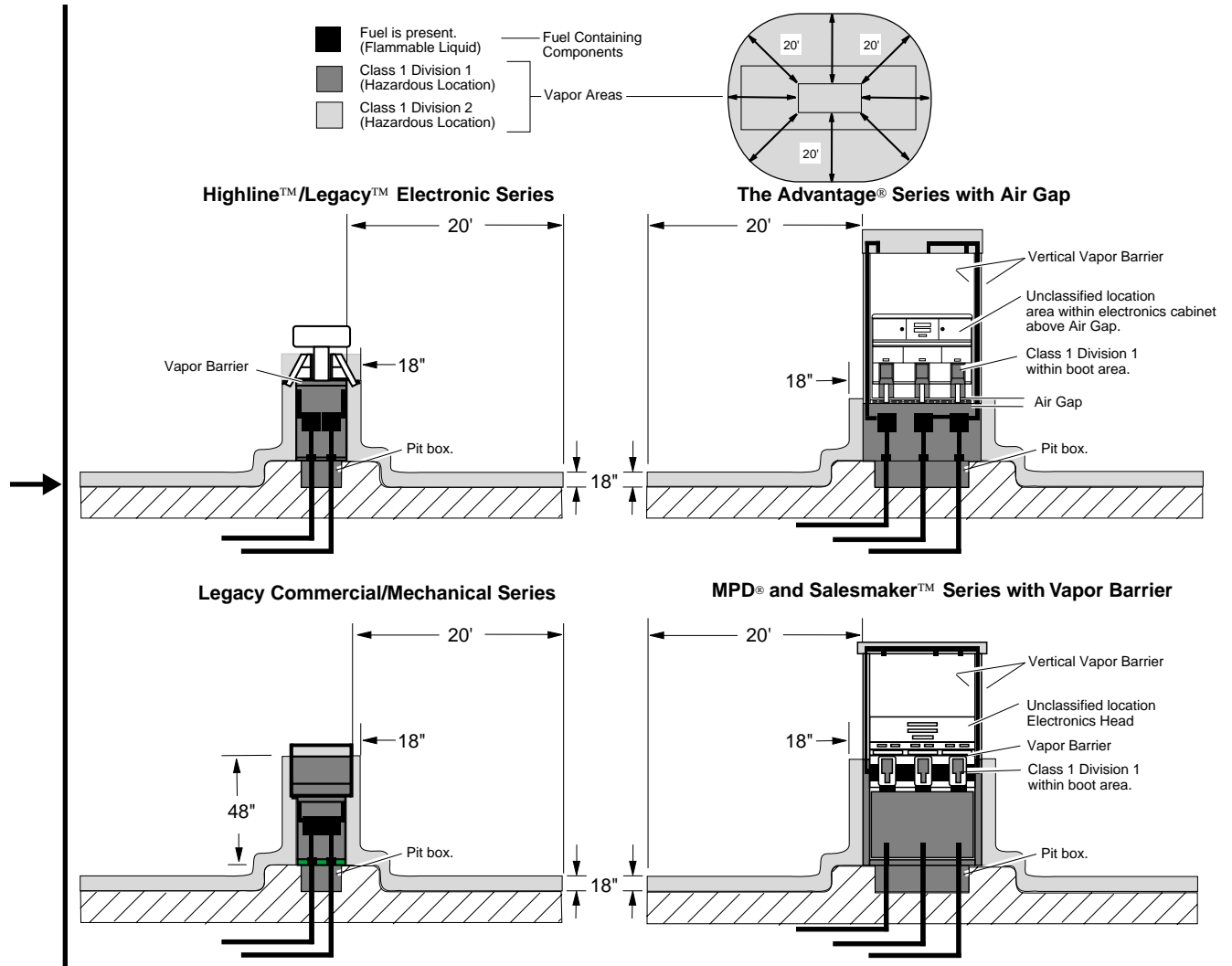

Note: The optional field installed canopy (if needed) must be listed for use over hazardous locations.

Safety



Alert Symbol

This is a standard ANSI* approved alert symbol. When you see this symbol, be alert to the potential for a personal injury.

* Reference American National Standard Bulletins ANSI Z535.

Signal Words

These are standard ANSI approved signal words. They alert you to personal safety hazards and precautions.



Safety Symbols

The following safety symbols are used throughout this manual to alert you to personal safety hazards and precautions.



Explosive



Flammable



Electricity



Use safety barricades.



No people in area.



No vehicles in area.

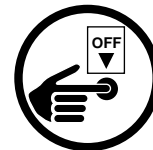

Use emergency power cutoff.



No open flames.



No smoking.



No power tools.



Wear eye protection.

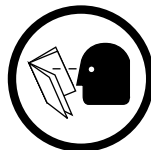

Read all related manuals.



Clean up spills.



Turn power off.



Collect fuel in approved containers.

Installation

Required Equipment and Materials

Below is a list of items required to properly install the equipment.

- Lifting device (crane, backhoe, forklift, etc.) to move and lift pump/dispenser
- Nylon slings (with a safety lift factor of 5) and screw-pin anchor shackles to lift high hose pump/dispenser
- Breakaways, hoses, nozzles, and swivels
- Barricades

Read NFPA 30A and NFPA 70

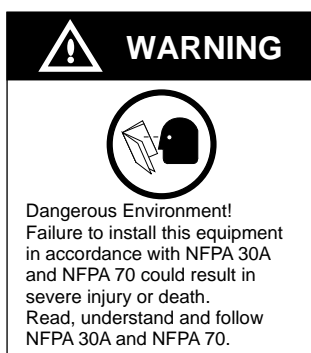

Before installing the equipment, read, understand and follow:

- The National Electric Code (NFPA 70)
- The Automotive and Marine Service Code (NFPA 30A)
- Any national, state, and local codes that may apply

The failure to install the equipment in accordance with NFPA 30A and NFPA 70 may adversely effect the safe use and operation of the system.

Accurate, sound installations reduce service calls: Use experienced, licensed contractors that practice accurate, safe installation techniques. Careful installation provides a sound troubleshooting framework for field repairs and can eliminate potential problems.

Equipment manufacturer must provide instructions for other equipment, such as submerged turbine pumps (STPs), leak detectors, and underground tanks. Gilbarco does not provide installation instructions for other manufacturer’s equipment.

Installation Instructions



1. Read all instructions before beginning.
2. Follow all safety precautions:
 - Barricade the area.
 - Do not allow vehicles or unauthorized people in the work area.
 - Do not smoke or allow open flames in the work area.
 - Do not use power tools in the work area.
 - Wear eye protection during the installation.
3. Use circuit breakers to turn off all power to pumps/dispensers and STPs. Multiple disconnects may be required.

4. Check the following for proper installation per criteria in the Pump and Dispenser Site Preparation Manual (MDE-2833):
 - Emergency Power Cutoff Switch
 - Circuit Breakers
 - STP Control Relay Boxes (dispensers only)
 - Isolation Relays (dispensers only)
 - Conduit and Wiring
 - Grounding
 - Shear Valves (dispensers only)
 - Piping and Fittings
 - Fuel Storage Tanks
 - Pressure Regulating Valves (above ground tanks only)
 - STPs (dispensers only)
 - Tank Leak Detectors (dispensers only)
 - Pit Boxes
5. Inspect pump/dispenser cartons and contents for shipping damage. Check tip-and-tell indicator. Gilbarco does not cover shipping damage under its warranty policy. Notify the shipper of any damage.
6. Remove lower panels (doors) of pump/dispenser.
- 7a. For The Advantage® Series remove outer sheathing to access the anchor bolt holes.
 - For one piece sheathing remove the four screws (2) at the top and (2) at the bottom of the side columns.
 - For two piece (painted sheathing) remove only the lower sheathing. You can do this by removing the two lower screws on the side columns. Grab sheathing at bottom. Carefully swing out sheathing from under top sheathing and remove.

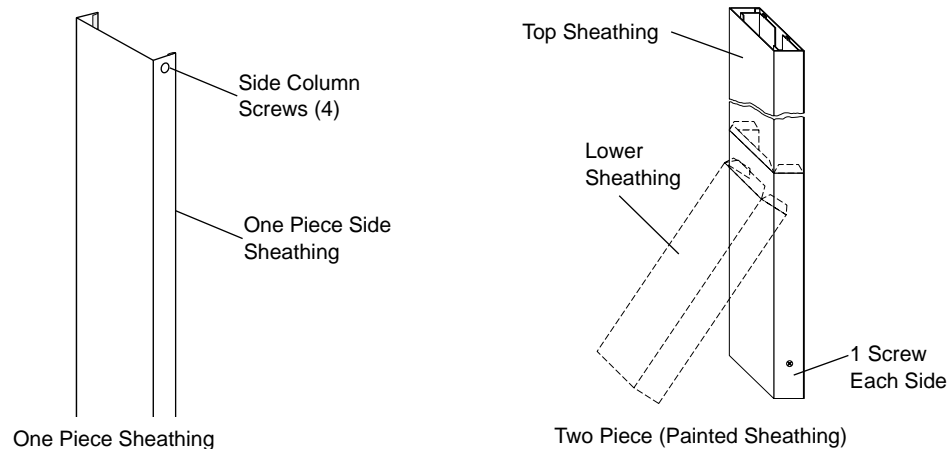

Note: For The Advantage® Series, bend out the six tabs located inside the column. These tabs are part of the sheathing. Use needle nose pliers or bent wire to pull tabs toward inside.

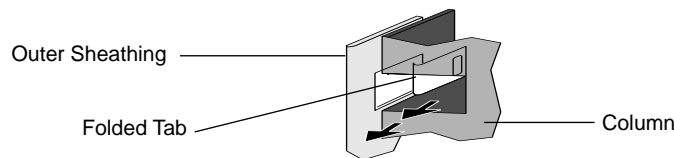

- Remove fiche paper and the lower half of the union on the pump/dispenser inlet pipe.

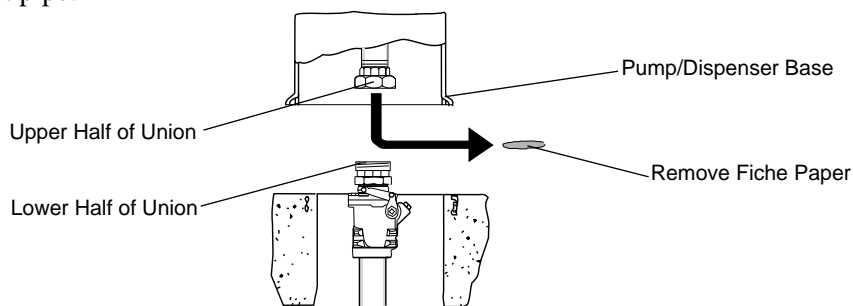

WARNING	
<p>Lifting heavy equipment can be hazardous. Equipment could fall and cause severe injury or death. Use lifting equipment. Stand clear from pump/dispenser when lifting and lowering.</p>	

- For dispensers, attach lower half of union to the shear valve. For pumps, attach lower half of union to riser pipe.

Note: You must install a listed shear valve for every product line at each dispenser. A shear valve is a NFPA30A required safety device. See the Site Preparation manual MDE-2833 for installation instructions.

- Be sure that the fuel grade for the product lines match the pump/dispenser brand panels and foundation layout. Product lines from the ground should have labels.

- Place pump/dispenser onto island.

Note: Pumps and dispensers vary in weight. See specifications in the addendum section. See MDE-2833 for minimum clearance requirements.

High-Hose Models

The Advantage® Series, MPD® and Salesmaker™ Series have hoisting brackets mounted on top of upper housing.

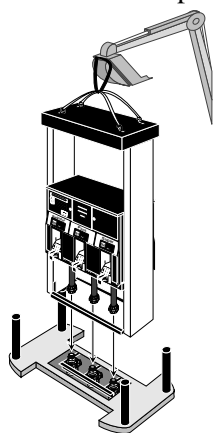

- Use nylon slings (safety lift factor of 5) with hoisting brackets to lift unit onto island. The Advantage Series requires three nylon slings and four screw pin shackles. The MPD and Salesmaker series requires two nylon slings and two screw pin shackles.

Note: Do not run slings around the columns. This will damage the columns or sheathing.

- Lift and position unit onto island.
- Remove slings and shackles.

Low-Hose Models

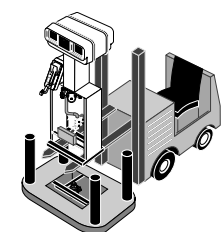

Legacy®, Highline™, Highline Salesmaker™, Trimline®, and Commercial Series units must be placed onto island using a fork lift.

Note: Do not lift by electronic head.

12. Line up pipes.

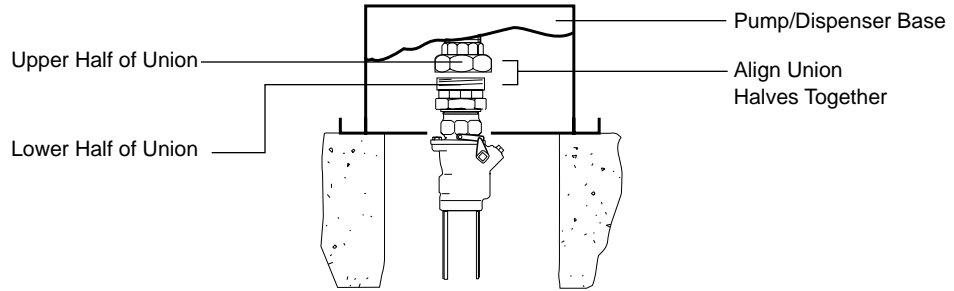

*Note: 1. Do not anchor unit to island now. Anchor shear valve first.
2. Do not use pry (crow) bar to position dispenser/pump over conduit or pipes. This could damage valves, junction box or other parts of the unit.*

13. Loosely connect union halves together.

Note: Illustrations shown are for dispensers in these steps. Pumps do not use shear valves. The connection to tank piping for pumps is the same less shear valve.

14. Double check alignment of pipes, conduit, and frame.

Note: Misaligned piping could result in a leak later.

15. Tighten union halves together.

16. Anchor shear valves to island form (concrete or pit box). If you do not anchor the shear valve, it will not operate correctly during a severe impact. Follow shear valve manufacturer instructions.

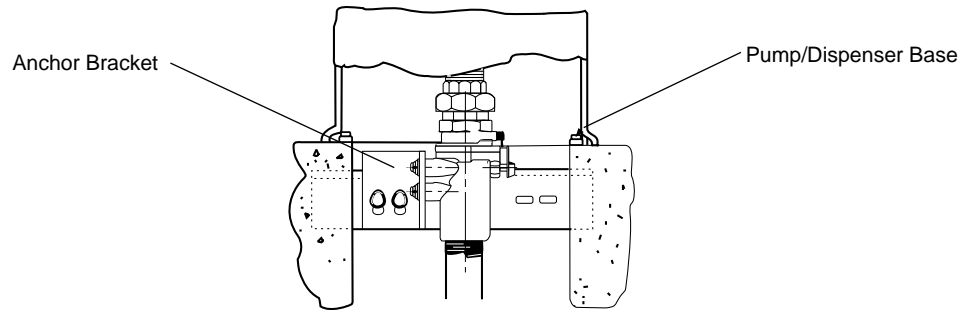

WARNING	
<p>Install shear valves correctly. Fire/Explosion could result in severe injury or death. Anchor the shear valve per manufacturer's instructions</p>	

17. Anchor the pump/dispenser securely to the island per foundation layout locations. (See product specific addendum).

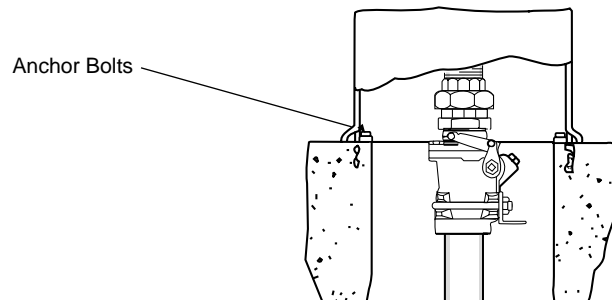

WARNING	
<p>Fire/Explosion could result in severe injury or death. NFPA 30A requires anchoring pumps/dispensers. Install all anchor bolts on the unit for safe operation of shear valves and hose breakaways.</p>	

Run field wiring to the main junction box through 1" conduit for The Advantage® series. Use 3/4" conduit for all other pumps/dispensers. Run external speaker wires (option) to conduit outlet box (see illustration below). Use Seal-Off (“Y”) fittings as a first connection where conduit leaves ground. Keep open ends up.

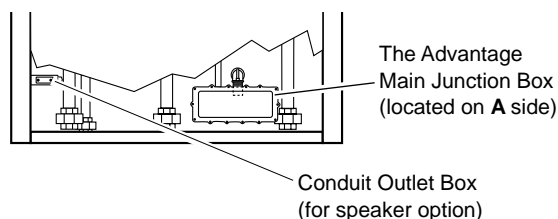

Note: 1. Wire all pumps/dispensers under NFPA 30A, NFPA 70, and applicable national, state and local codes and regulations. Wire all circuits N.E.C. Class 1, except outputs to speaker (intercom) which must be N.E.C. Class 2. Gilbarco two-wire is N.E.C. Class 1 and may share the main power conduit. 2. All field wiring (except speaker) enters the pump/dispenser through the AC Main Junction Box on the “A” Side of the pump/dispenser. Speaker wiring enters through an optional conduit outlet box (see Elevation/Footprint in specific addendum). Gilbarco recommends only licensed electricians wire pumps/dispensers.

18. Tighten conduit unions.



19. Test wire insulation before connecting wires. This checks for damage that can occur while pulling wires through the conduit.
- Disconnect wires at both ends. If you do not disconnect wires at both ends, you can damage the pump/dispenser electronics.
 - Test the conduit wiring ends by using a insulation/megger tester.
 - Connect one tester lead to wire under test.
 - Connect other tester lead to ground.
 - Measure resistance. Follow test set manufacturer instructions. Insulation resistance more than 50 megohms is satisfactory. Check local authority requirements.
 - Repeat above steps for all wires.
 - Repeat test between all wires.
20. Seal each conduit entering and exiting pump/dispenser by pouring sealing compound into open leg of “Y” fitting. The compound thickness shall not be less than the trade size of the conduit and never less than 5/8" (see NFPA 70 Section 510-5 [C.3]).
21. Attach grounding wire to green grounding screw in junction box.
22. Make connections in junction box (see field wiring diagrams). Do not disturb sealing compound around wire in existing conduit. Do not disturb factory wiring in electronic cabinet.

23. For units with lighted canopies:

Note: Use lighted canopies listed for use over hazardous locations. You must use the following installation method to meet NFPA 30A requirements.

- Remove upper housing cover to expose canopy light conduit and wires.
- Rotate conduit elbow, nipple, and wires 90 degrees so they point upward.
- Remove knockout from upper housing cover. Make sure the hole aligns with the upturned conduit.

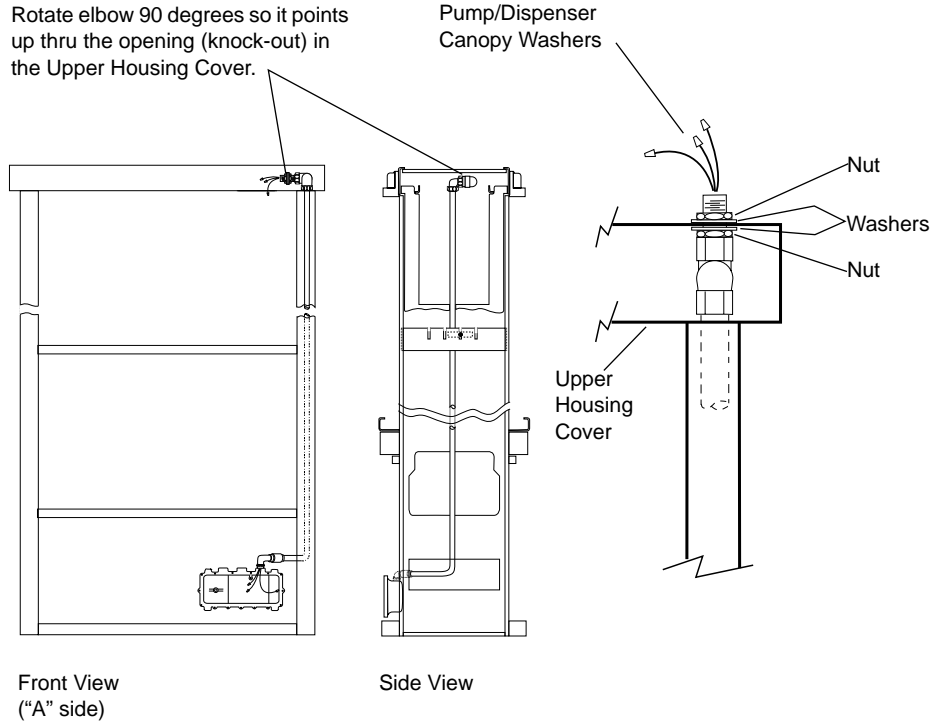



- Place a nut and then a washer on conduit below upper housing cover. Position nut and washer to meet bottom-side of housing cover. Replace piping housing cover so the upturned conduit nipple sticks through knockout hole. Place a washer and then a nut on conduit above cover (see illustration). Washers must be against housing cover.

Note: Do not use canopy conduit for running wires to station overhead canopy lights, fore court lights, or to other equipment.

24. Use wire nuts or lugs to make good connections. Cap all unused wires.
25. Use pipe plugs to seal unused openings in junction boxes.
26. Double check all wiring connections for wire nuts, lugs, caps, etc. Replace junction box cover and tighten all bolts. Do not use gaskets on junction box. Do not pinch wires.
27. Replace lower doors and side sheathing.

 WARNING

<p>High Voltage Electrical shock can result in severe injury or death. Replace all bolts and tighten junction box cover before turning on unit AC power.</p>

WARNING	
	
<p>Hose pulled away from pump/dispenser exposes fuel. Explosion and fire could result in severe injury or death. Installation of breakaways is required by NFPA 30A</p>	

28. Install listed breakaways to hoses. Follow breakaway manufacturer instructions.
- Clean all threads.
 - Place sealant on male threads only. Follow sealant manufacturer instructions.

Note: Use only listed pipe sealant for use with petroleum products. Remove sealant if it gets inside hose or fittings. Clean off excess sealant. Do not use teflon tape or damage to unit may occur.

- Use a smooth faced wrench to tighten all fittings securely. Do not over-tighten.

Note: Do not tighten breakaway by twisting hose. This could damage coupling.

29. For high-hose units, install breakaway to pump/dispenser outlet. For low-hose units, install between hose clamp and nozzle.

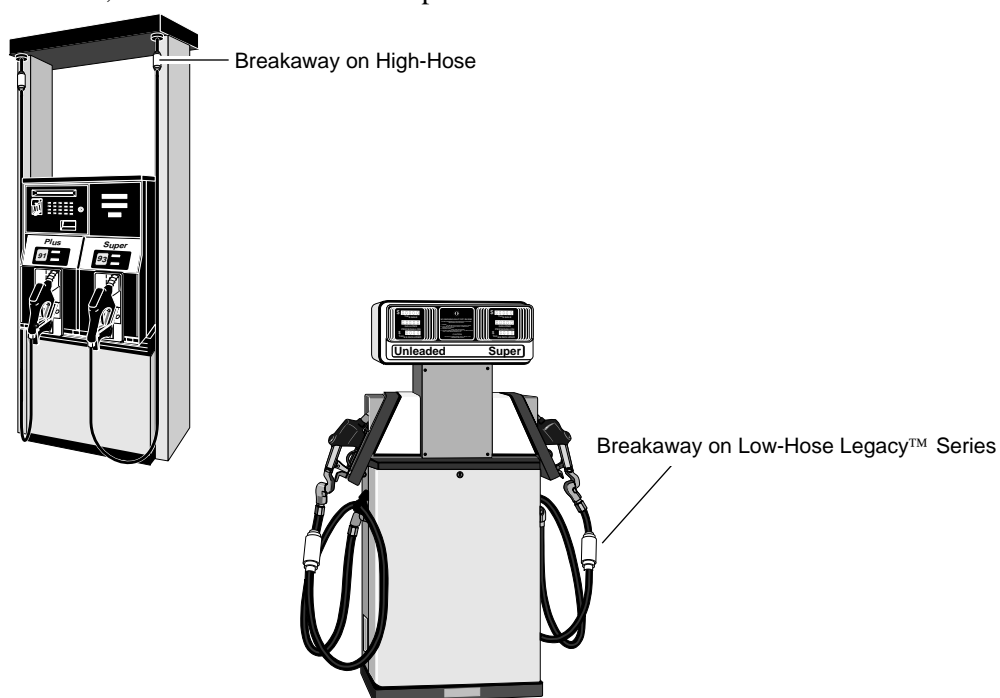

30. Install swivel to hose. Follow swivel manufacturer instructions.

31. Install nozzle to swivel. Follow nozzle manufacturer instructions.

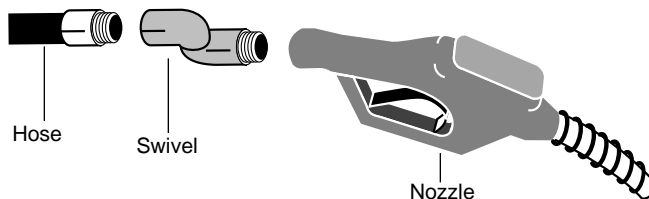

32. Check for correct nozzle cradle/hook type (vapor, non-vapor, etc.).

33. **Do not turn on AC power.** Applying power now voids warranty. When installation is complete, a Gilbarco Authorized Service Contractor must perform a start-up.

