

# ***Operator's Quick Help***

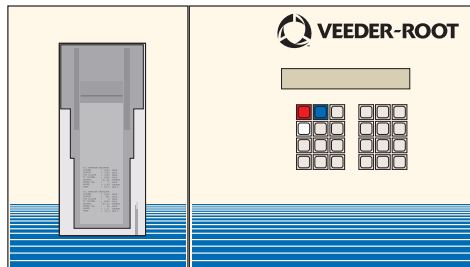

***ProPlus***

***ProMax***

## Notice

Veeder-Root makes no warranty of any kind with regard to this publication, including, but not limited to, the implied warranties of merchantability and fitness for a particular purpose.

Veeder-Root shall not be liable for errors contained herein or for incidental or consequential damages in connection with the furnishing, performance, or use of this publication.

Veeder-Root reserves the right to change system options or features, or the information contained in this publication.

This publication contains proprietary information which is protected by copyright. All rights reserved. No part of this publication may be photocopied, reproduced, or translated to another language without the prior written consent of Veeder-Root.

For complete warranty, technical support, and additional product information, refer to your console's Operator Manual.

# Table of Contents

Console Operating Features .....	1	In-Tank Alarms .....	13
Key Functions .....	2	Liquid Sensor Alarms .....	17
Automatic Reports .....	3	Dual-Float Discriminating Sensor Alarms .....	18
Business Inventory Reconciliation (BIR Option) .....	4	Vapor Sensor Alarms .....	19
Variance Reports .....	5	Groundwater Sensor Alarms .....	20
Maintenance Report.....	6	Vacuum Sensor Alarms .....	21
In-Tank Leak Test Report .....	7	Mag Sump Sensor Alarms .....	22
Inventory Report .....	7	PLLD/WPLLD Line Leak Detection Alarms.....	23
Last Shift Inventory Report .....	8	System Status Messages .....	24
Inventory Increase Report .....	8	To Start An In-Tank Leak Test .....	25
Entering A Ticketed Delivery Volume .....	9	To Stop In-Tank Leak Testing .....	26
Mag Sump Sensor Leak Test Results .....	10	Pressurized Line Leak Detection Tests .....	27
Smart Sensor Status.....	10	Wireless Pressurized Line Leak Detection Tests .....	29
Warnings And Alarms .....	11	To Set The System Date .....	31
In-Tank Warning And Alarm Levels .....	12	To Set The System Time .....	33

# Console Operating Features

*Display (showing operating mode - no alarms)*



*Alarm Light - Red*



*Warning Light - Yellow*



*Power Light - Green*

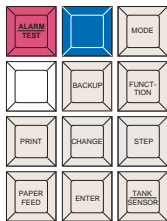

*Operating Keys*



*Alphanumeric Keys*

*Blue (Maintenance Tracker) & White (Maintenance Report) keys available Version 27 and later.*

# Key Functions



Press to silence the alarm. This will not reset the display or disable any alarm functions.



Contractor plugs ID Key into TLS and presses the blue key to log in for a work session.



Press to select the system mode: Operating Mode, Setup Mode, Diagnostic Mode.



Press white key to print out the Maintenance Report if Maintenance History or Tracker is enabled.



Used to move back through Steps, Functions and Modes.



Press to select the various Functions within each Mode.



Press to generate the various reports.



Press to change to a different option than currently displayed.



Press to move to the next procedure within each function.



Press to advance the paper through the printer.



Press to select an option. Also to start leak tests.



Press to change to the next tank or sensor.



The period (.) is on key "1". The decimal point (•) is on the Right Arrow key (➡).



Select a character by successive presses of the key. Press once for "A". Press again for "B", again for "C" and a fourth time to enter a "2".



The zero key has a space (□), a hyphen (-) and the comma (,).



The Arrow keys are used to move the cursor left and right (as with this example) without changing the displayed character.

# Automatic Reports

## INVENTORY INCREASE REPORT

*TI: REGULAR UNLEAD  
INVENTORY INCREASE*

*INCREASE START  
MMM DD, YYYY HH:MM XM*

*VOLUME = 5146 GALS  
HEIGHT = 44 INCHES  
WATER = 0.00 INCHES  
TEMP = 46.8 DEG F*

*INCREASE END  
MMM DD, YYYY HH:MM XM*

*VOLUME = 8104 GALS  
HEIGHT = 84 INCHES  
WATER = 0.00 INCHES  
TEMP = 47.2 DEG F*

*GROSS INCREASE = 2958  
TC NET INCREASE = 2983*

This report is generated after each delivery. It shows the volume of the tank contents before and after delivery and the difference between the two volumes; which is the amount delivered less any sales during the delivery period.

Depending on the system configuration, the report may also show the amount delivered taking into account changes in volume caused by temperature changes (TC NET INCREASE).

There will be a delay of at least four minutes between the end of the delivery and the printing of the report while the console waits for the fuel level in the tank to stabilize.

## ADJUSTED DELIVERY REPORT (BIR Option)

*TI: PRODUCT 1  
ADJUSTED DELIVERY REPORT*

*MMM DD, YYYY HH:MM XM*

*DELIVERY VOLUME = 1200  
TC DELIVERY VOLUME = 1189*

During the delivery the TLS-350R is continuously monitoring any sales from the tank being delivered to.

Within 60 minutes after printing the Inventory Increase Report, the TLS-350R generates an Adjusted Delivery Report.

The TLS-350R adjusts the gross increase fuel volume by adding any fuel dispensed from that tank during the delivery.

If Temperature Compensation has been enabled the temperature compensated volume is also adjusted and will appear on the report.

## Business Inventory Reconciliation (BIR Option)

The TLS-350R, in addition to accurately measuring the contents of each tank, also monitors the amount of fuel dispensed at the pumps. The volume of fuel dispensed is then compared with the fall in fuel level in the appropriate tank. This process is called **reconciliation**.

The results of the reconciliation process are available as **Reconciliation Reports**. These reports are available for each worked shift, for each day, or for any other specified period.

### TO PRINT A RECONCILIATION REPORT

Press **Mode** until the display shows:

RECONCILIATION MODE  
PRESS <FUNCTION> TO CONT

Press **Function** twice and **Step**, and the display will show:

DISPLAY AND PRINT  
REPORT TYPE: SHIFT

Press **Print** for a Shift Report.

Press **Change**, **Enter** and **Print** for a Daily Report.

Press **Change** twice, **Enter** and **Print** for a Periodic Report.

Press **Mode** 3 times to return to the Operating mode.

# Variance Reports

If enabled in Setup Mode, you can generate daily, weekly, and/or periodic Delivery Variance Reports, Book Variance Reports, and Variance Analysis Reports. Also, you can display and print Variance Reports for all products, or for a specific product. (Refer to the Variance Reports paragraph in the Reconciliation section of the Operator's Manual for complete report printing options, such as printing weekly or periodic reports.)

## TO PRINT DELIVERY VARIANCE REPORTS

Press **Mode** until the display shows:

RECONCILIATION MODE  
PRESS <FUNCTION> TO CONT

Press **Function** until the display shows:

DISPLAY AND PRINT DLVY  
PRESS <STEP> TO CONTINUE

Press **Print** to printout the daily Delivery Variance reports for all products.

## TO PRINT BOOK VARIANCE REPORTS

Press **Mode** until the display shows:

RECONCILIATION MODE  
PRESS <FUNCTION> TO CONT

Press **Function** until the display shows:

BOOK VARIANCE  
PRESS <STEP> TO CONTINUE

Press **Print** to printout the daily Book Variance reports for all products.



## Variance Reports (Continued)

### TO PRINT VARIANCE ANALYSIS REPORTS

Press **Mode** until the display shows:

RECONCILIATION MODE  
PRESS <FUNCTION> TO CONT

Press **Function** until the display shows:

VARIANCE ANALYSIS  
PRESS <STEP> TO CONTINUE

Press **Print** to printout the daily Variance Analysis reports for all products.

## Maintenance Report

Press the White (Maintenance Report) key on the front panel:

MAINTENANCE REPORT  
PRESS <PRINT>

Press **Print** to print the default number of records (20), starting from the default (current) date; or you can press **Step** to enter a date from which to start printing records, then press **Step** to enter the number of records to print from the selected date (up to 70 records).

## In-Tank Leak Test Report

MMM DD, YYYY HH:MM XM  
ALL FUNCTIONS NORMAL

Press **Function** until the display shows:

IN-TANK TEST RESULTS  
PRESS <STEP> TO CONTINUE

Press **Print** to generate a report for all tanks.

To generate a report for an individual tank, press **Step** and **Tank** to select the desired tank then **Print** to generate the report.

## Inventory Report

MMM DD, YYYY HH:MM XM  
ALL FUNCTIONS NORMAL

Press **Print** for a complete inventory report for all tanks.

To display the inventory information from each tank, press **Function** until the display shows:

IN-TANK INVENTORY  
PRESS <STEP> TO CONTINUE

Press **Step** and the system will display the fuel volume for the first tank.

Press **Step** to view other in-tank information.

Press **Tank** to select a different tank.

Press **Print** to print the report.

## Last Shift Inventory Report

MMM DD, YYYY HH:MM XM  
ALL FUNCTIONS NORMAL

Press **Function** until the display shows:

LAST SHIFT INVENTORY  
PRESS <STEP> TO CONTINUE

Press **Step** to select the shift and to display inventory data.

Press **Tank** to select a different tank.

Press **Print** to print the report.

## Inventory Increase Report

Page 8

MMM DD, YYYY HH:MM XM  
ALL FUNCTIONS NORMAL

Press **Function** once and **Step** until you see the Delivery message (the last delivery amount):

T1: REGULAR UNLEADED  
DELIVERY = 2958 GALS

Press **Tank** to select a different tank.

Press **Print** to print the delivery report for the tank shown.

## Entering A Ticketed Delivery Volume (BIR Option)

The Delivery Maintenance function, if enabled in Setup Mode, lets you edit, view, and print information about ticketed deliveries (refer to the Delivery Maintenance section of the Operator's Manual for complete instructions and printing options).

MMM DD, YYYY HH:MM XM  
ALL FUNCTIONS NORMAL

Press **Function** until the display shows:

DELIVERY MAINTENANCE  
PRESS <STEP> TO CONTINUE

Press **Step** until the display shows:

SELECT: EDIT/VIEW  
T1: (product)

Press **Tank** until the desired product is visible in the display. If necessary, press **Step** until the date/time of the delivery appears. Press **Print** to print out a copy of that ticketed delivery (Notice that the ticket volume equals 0 on the printout). Press **Change**, then enter the delivered volume from the ticket using the number keys. Press **Enter** to confirm your choice. Press **Backup, Step** and **Print** to print out a copy of the revised report.

## Mag Sump Sensor Leak Test Results

In the operating mode, press **Function** until the display shows:

```
MAG SUMP LK TEST RESULTS
PRESS <STEP> TO CONTINUE
```

Press **Step** to display the message:

```
s1: MM-DD-YY   HH:MM XM
LAST PASSED TEST
```

Press **Print** to printout the last passed Mag Sump Sensor leak test results.

Press **Step** to display the message:

```
s1: SUMP 1
PRESS PRINT FOR HISTORY
```

Press **Print** to printout the leak test history for this sensor which shows the last test results and the last passed test for each year, up to the last 10 years (if applicable).

## Smart Sensor Status

Smart sensor status reports the status of the smart sensors connected to the Smart Sensor/Press or Smart Sensor Module and indicates if an alarm condition exists. To select smart sensor status, press **Function** until you display the message:

```
SMART SENSOR STATUS
PRESS <STEP> TO CONTINUE
```

To print a complete smart sensor status report, press **Print**. To view the smart sensor status for a particular sensor, press **Step** to display the message:

```
s#: (Location)
(Status Indicator)
```

If the sensor is functioning properly and no alarm conditions exist, the system displays the message SENSOR NORMAL.

## Warnings And Alarms

The TLS console is constantly monitoring its probes and sensors for warning and alarm conditions, such as fuel leaks, excessively high or low fuel levels, and equipment problems.

When in the Operating mode and there is no warning or alarm condition active, the system displays the “ALL FUNCTIONS NORMAL” message.

If a warning or alarm condition occurs the system displays the alarm type and its location, either tank, input or sensor number.

The system prints an alarm report showing the warning or alarm type, its location and the date and time the warning or alarm condition occurred.

If more than one condition exists the console will flash the messages alternately.

### WARNINGS

These indicate that an in-tank alarm is imminent or that a system fault has occurred.

### ALARMS

Alarms indicate a potentially dangerous situation may have occurred.

**WARNING! DO NOT IGNORE ALARMS! Know the alarm response procedures for your site.**

#### To Switch Off All Warnings and Alarms

Press the red ALARM/TEST key to silence the alarm.



The front panel warning and alarm lights cannot be turned off until the cause of the condition has been rectified.

Similarly the warning and alarm displays remain until the cause of the condition has been rectified.

#### PLLD/WPLLD Alarm Information

For PLLD/WPLLD line leak detection alarms, refer to following manuals:

- PLLD/WPLLD Alarm Quick Help manual (P/N 577013-727)
- TLS-350/TLS-350R Operator's Manual (P/N 576013-610)

# In-Tank Warning And Alarm Levels

**Single-Wall Tanks**

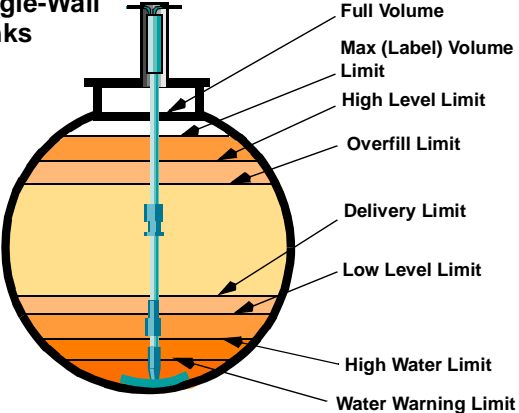

**Double-Wall Tanks**

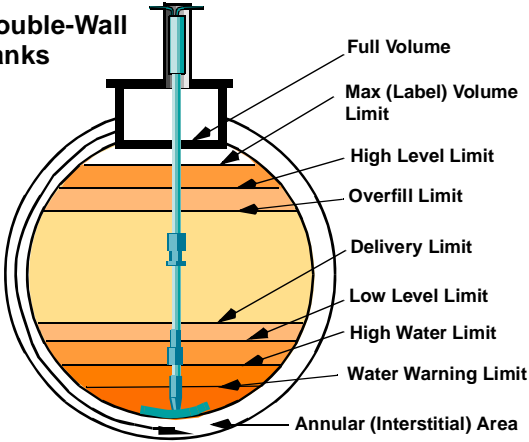

# In-Tank Alarms

MMM DD, YYYY HH:MM XM  
T1: HIGH WATER WARNING

*(Flashing Yellow light)*



**CAUSE:**

Water collecting in the tank has exceeded the Water Warning level.

**ACTION:**

Close all pumps attached to this tank. Contact your VR Service Contractor for advice.

MMM DD, YYYY HH:MM XM  
T1: DELIVERY NEEDED

*(Flashing Yellow light)*



**CAUSE:**

Fuel level in the tank is below the Delivery Needed level.

**ACTION:**

Arrange a delivery.

MMM DD, YYYY HH:MM XM  
T1: INVALID FUEL LEVEL

*(Flashing Yellow light)*



**CAUSE:**

Fuel and water level floats on the probe are too close together due to a lack of fuel in the tank.

**ACTION:**

Arrange a delivery.

MMM DD, YYYY HH:MM XM  
T1: TANK TEST ACTIVE

*(Flashing Yellow light)*



**CAUSE:**

If enabled, the system will display this message when a tank test is in progress.

**ACTION:**

Do not deliver to or dispense from the tank being tested.



# In-Tank Alarms (Continued)

**MMM DD, YYYY HH:MM XM**  
**T1: OVERFILL ALARM**

*(Flashing Red light)*



**CAUSE:**  
Fuel level in the tank has exceeded the Overfill Level during a delivery.

**ACTION:**  
**Stop the delivery immediately!**

**MMM DD, YYYY HH:MM XM**  
**T1: LOW PRODUCT ALARM**

*(Flashing Red light)*



**CAUSE:**  
Fuel level in the tank has dropped below the Low Product Alarm level.

**ACTION:**  
Arrange a delivery.

**MMM DD, YYYY HH:MM XM**  
**T1: LEAK ALARM**

*(Flashing Red light)*



**CAUSE:**  
Fuel loss has exceeded the pre-programmed limit during a leak test in the tank. This indicates a possible leak.

**ACTION:**  
Contact your VR Service Contractor for advice.

**MMM DD, YYYY HH:MM XM**  
**T1: HIGH WATER ALARM**

*(Flashing Red light)*



**CAUSE:**  
Water at the bottom of the tank has exceeded the High Water Alarm level.

**ACTION:**  
**Close all pumps attached to this tank.** Contact your VR Service Contractor for advice.

## In-Tank Alarms (Continued)

MMM DD, YYYY HH:MM XM  
T1: SUDDEN LOSS ALARM

*(Flashing Red light)*



**CAUSE:**

Fuel loss in the tank has exceeded a pre-set limit during a Leak Test. This indicates a possible leak, fuel being dispensed or other unauthorized loss.

**ACTION:**

Check that fuel has not been dispensed from the tank during the test period. Contact your VR Service Contractor for advice.

MMM DD, YYYY HH:MM XM  
T1: HIGH PRODUCT ALARM

*(Flashing Yellow light)*



**CAUSE:**

Fuel level in the tank has exceeded the High Product Alarm limit.

**ACTION:**

**Stop the delivery immediately!**

MMM DD, YYYY HH:MM XM  
T1: MAX PRODUCT ALARM

*(Flashing Red light)*



**CAUSE:**

Fuel level in the tank has exceeded the Safe Working Capacity.

**ACTION:**

**Stop the delivery immediately!**

MMM DD, YYYY HH:MM XM  
T1: PROBE OUT ALARM

*(Flashing Red light)*



**CAUSE:**

There is a fault with the sensing probe in the tank.

**ACTION:**

Contact your VR Service Contractor for advice.

## In-Tank Alarms (Continued)

MMM DD, YYYY HH:MM XM  
T1: PER TST NEEDED ALM

*(Flashing Red light)*



**CAUSE:**

A periodic in-tank leak test has not been successfully completed within the preset time period.

**ACTION:**

Schedule a 0.2 gph (0.76 lph) test.

MMM DD, YYYY HH:MM XM  
T1: PERIODIC TEST FAIL

*(Flashing Red light)*



**CAUSE:**

In-tank leak periodic (0.2 gph [0.76 lph]) test failed.

**ACTION:**

Rerun in-tank leak test. If second test fails, contact your VR Service Contractor for advice.

MMM DD, YYYY HH:MM XM  
T1: ANN TST NEEDED ALM

*(Flashing Red light)*



**CAUSE:**

An annual in-tank leak test has not been successfully completed within the preset time period.

**ACTION:**

Schedule a 0.1 gph (0.38 lph) test.

MMM DD, YYYY HH:MM XM  
T1: ANNUAL TEST FAIL

*(Flashing Red light)*



**CAUSE:**

In-tank leak annual (0.1 gph [0.38 lph]) test failed.

**ACTION:**

Rerun in-tank leak test. If second test fails, contact your VR Service Contractor for advice.

# Liquid Sensor Alarms

MMM DD, YYYY HH:MM XM  
L1: FUEL ALARM

*(Flashing Red light)*



**CAUSE:**

The sensor has detected liquid in the sump being monitored.

**ACTION:**

Investigate the cause of the alarm and take appropriate action.

MMM DD, YYYY HH:MM XM  
L1: SENSOR OUT ALARM

*(Flashing Red light)*



**CAUSE:**

The sump sensor has been disconnected or is faulty.

**ACTION:**

Contact your VR Service Contractor for advice.

MMM DD, YYYY HH:MM XM  
L1: INTERSTITIAL ALARM

*(Flashing Red light)*



**CAUSE:**

The Interstitial Monitor for the tank has detected a change in the interstitial fluid level; a fuel leak may have occurred.

**ACTION:**

Call a Service Contractor to check for fluid loss.

# Dual-Float Discriminating Sensor Alarms

MMM DD, YYYY HH:MM XM  
L1: FUEL ALARM

*(Flashing Red light)*



**CAUSE:**

The sensor at the location shown has detected fuel vapor or liquid.

**ACTION:**

Investigate the cause of the alarm and take appropriate action.

MMM DD, YYYY HH:MM XM  
L1: LIQUID ALARM

*(Flashing Yellow light)*



**CAUSE:**

The sensor at the location shown has detected at least 1 inch of non-hydrocarbon liquid.

**ACTION:**

Contact your VR Service Contractor for advice.

MMM DD, YYYY HH:MM XM  
L1: HIGH LIQUID ALARM

*(Flashing Yellow light)*



**CAUSE:**

The sensor at the location shown has detected at least 8 inches of non-hydrocarbon liquid.

**ACTION:**

Contact your VR Service Contractor for advice.

MMM DD, YYYY HH:MM XM  
L1: SENSOR OUT ALARM

MMM DD, YYYY HH:MM XM  
L1: SHORT ALARM

*(Flashing Yellow light)*



**CAUSE:**

The sensor at the location shown has been disconnected or is inoperative.

**ACTION:**

Contact your VR Service Contractor for advice.

# Vapor Sensor Alarms

MMM DD, YYYY HH:MM XM  
V1: FUEL ALARM

*(Flashing Red light)*



**CAUSE:**

The vapor sensor has detected fuel vapor in the monitoring well.

**ACTION:**

Investigate the cause of the alarm and take appropriate action.

MMM DD, YYYY HH:MM XM  
V1: WATER ALARM

*(Flashing Yellow light)*



**CAUSE:**

The vapor sensor is immersed in water and will not work.

**ACTION:**

Contact your VR Service Contractor for advice.

MMM DD, YYYY HH:MM XM  
V1: SENSOR OUT ALARM

*(Flashing Yellow light)*



**CAUSE:**

The vapor sensor has been disconnected or is inoperative.

**ACTION:**

Contact your VR Service Contractor for advice.

MMM DD, YYYY HH:MM XM  
V1: SHORT ALARM

*(Flashing Yellow light)*



**CAUSE:**

The vapor sensor is faulty.

**ACTION:**

Contact your VR Service Contractor for advice.

# Groundwater Sensor Alarms

MMM DD, YYYY HH:MM XM  
G1: FUEL ALARM

*(Flashing Red light)*



**CAUSE:**

The groundwater sensor has detected fuel.

**ACTION:**

Investigate the cause of the alarm and take appropriate action.

MMM DD, YYYY HH:MM XM  
G1: WATER ALARM

*(Flashing Yellow light)*



**CAUSE:**

The water level in the monitoring well shown is below the groundwater sensor (this may occur during periods of severe drought).

**ACTION:**

If the condition persists contact your VR Service Contractor for advice.

MMM DD, YYYY HH:MM XM  
G1: SENSOR OUT ALARM

*(Flashing Yellow light)*



**CAUSE:**

The groundwater sensor at the location shown is inoperative.

**ACTION:**

Contact your VR Service Contractor for advice

MMM DD, YYYY HH:MM XM  
G1: SHORT ALARM

*(Flashing Yellow light)*



**CAUSE:**

The groundwater sensor at the location shown is inoperative.

**ACTION:**

Contact your VR Service Contractor for advice.

# Vacuum Sensor Alarms

MMM DD, YYYY HH:MM XM  
s1: VACUUM WARNING

*(Flashing Yellow light)*



**CAUSE:**

There may be a leak in the monitored interstitial space. There is a possibility that a No Vacuum alarm will be posted in the future.

**ACTION:**

Find and repair vacuum leak then perform a Vac Sensor Manual Test (Diag Mode).

MMM DD, YYYY HH:MM XM  
s1: NO VACUUM ALARM

*(Flashing Red light)*



**CAUSE:**

There is no vacuum in the interstitial space.

**ACTION:**

Find and repair vacuum leak then perform a Vac Sensor Manual Test (Diag Mode).

MMM DD, YYYY HH:MM XM  
s1: COMMUNICATION ALARM

*(Flashing Red light)*



**CAUSE:**

Hardware failure - sensor or interconnecting wiring to console.

**ACTION:**

Contact your VR Service Contractor for advice.



# Mag Sensor Alarms

MMM DD, YYYY HH:MM XM  
s1: FUEL ALARM

(Flashing Red light)



**CAUSE:**  
Monitored parameter exceeded preset threshold.

**ACTION:**  
Contact your VR Service Contractor for advice.

MMM DD, YYYY HH:MM XM  
s1: WATER ALARM

(Flashing Red light)



**CAUSE:**  
Monitored parameter exceeded preset threshold.

**ACTION:**  
Contact your VR Service Contractor for advice.

MMM DD, YYYY HH:MM XM  
s1: COMMUNICATION ALARM

(Flashing Red light)



**CAUSE:**  
Hardware failure - sensor or interconnecting wiring to console.

**ACTION:**  
Contact your VR Service Contractor for advice.

# Pump Relay Monitor Alarm

MMM DD, YYYY HH:MM XM  
r1: PUMP RELAY ALARM

(Flashing Red light)



**CAUSE:**  
Pump continues to run after it was instructed to stop, or pump continuously running longer than preset time.

**ACTION:**  
Contact your VR Service Contractor for advice.

# PLLD/WPLLD Line Leak Detection Alarms

MMM DD, YYYY HH:MM XM  
Q1: GROSS LINE FAIL

MMM DD, YYYY HH:MM XM  
W1: GROSS LINE FAIL

*(Flashing Red light)*



**CAUSE:**  
3 gph (11.3 lph) line test failure.  
Dispensing halts, if programmed to do so, while the alarm is active.

**ACTION:**  
Consult W/PLLD Alarm Quick Help Guide and Pressure Line Leak Diag (Diagnostic Mode).

MMM DD, YYYY HH:MM XM  
Q1: ANNUAL LINE FAIL

MMM DD, YYYY HH:MM XM  
W1: ANNUAL LINE FAIL

*(Flashing Red light)*



**CAUSE:**  
0.1 gph (0.38 lph) test failure.  
Dispensing halts, if programmed to do so.

**ACTION:**  
Consult W/PLLD Alarm Quick Help Guide and Pressure Line Leak Diag (Diagnostic Mode).

MMM DD, YYYY HH:MM XM  
Q1: PERIOD LINE FAIL

MMM DD, YYYY HH:MM XM  
W1: PERIOD LINE FAIL

*(Flashing Red light)*



**CAUSE:**  
0.2 gph (0.76 lph) test failure.  
Dispensing halts, if programmed to do so.

**ACTION:**  
Consult W/PLLD Alarm Quick Help Guide and Pressure Line Leak Diag (Diagnostic Mode).

MMM DD, YYYY HH:MM XM  
Q1: SHUTDOWN ALARM

MMM DD, YYYY HH:MM XM  
W1: SHUTDOWN ALARM

*(Flashing Red light)*



**CAUSE:**  
System shut down line because of failed line leak test, or an alarm assigned to disable the line is active.

**ACTION:**  
Identify offending alarm, and see Table 27-11, -12 in manual no. 576013-610 for corrective action.

# System Status Messages

MMM DD, YYYY HH:MM XM  
PAPER OUT

*(Flashing Yellow light)*



**CAUSE:**  
The paper roll is empty.

**ACTION:**  
Replace paper (see **Changing the Printer Paper**).

MMM DD, YYYY HH:MM XM  
BATTERY OFF

*(Flashing Red light)*



**CAUSE:**  
The system backup battery has failed.

**ACTION:**  
**Do not switch off power to the system.** Contact your VR Service Contractor for advice.

MMM DD, YYYY HH:MM XM  
PRINTER ERROR

*(Flashing Yellow light)*



**CAUSE:**  
Either the printer release lever is in the down position, or the printer is inoperative.

**ACTION:**  
Check that the paper release lever is in the up position and, if necessary, contact your VR Service Contractor for advice.

MMM DD, YYYY HH:MM XM  
SETUP DATA WARNING

*(Flashing Yellow light)*



**CAUSE:**  
A system error has occurred.

**ACTION:**  
Contact your VR Service Contractor for advice.

## To Start An In-Tank Leak Test

Press **Function** until the display shows:

START IN-TANK LEAK TEST  
PRESS <STEP> TO CONTINUE

To test individual tanks press **Step**, **Change**, **Enter** and **Step**. To test all tanks press **Step** twice and the display will show:

TEST CONTROL: ALL TANKS  
TIMED DURATION

To end the test manually press **Change**, **Enter** and **Step**; or to set a duration for the test press **Step**. Select the test accuracy, either 0.20 gal/hr or 0.10 gal/hr. To change the setting press **Change** and **Enter**. Press **Step** to continue. Enter the Test Duration in hours, press **Enter** and **Step**. The display will show:

START LEAK TEST TANKS  
PRESS <ENTER>

Press **Enter** to start the test. For individual tanks press **Tank** to go to the next tank.



- Do not start an in-tank leak test if there has been a delivery to the tank to be tested within the previous 8 hours. This will result in an invalid test.
- A delivery to a tank being tested results in an invalid test.
- Dispensing from a tank being tested will cause a Sudden Loss Alarm.

## To Stop In-Tank Leak Testing

Press **Function** until the display shows:

**STOP IN-TANK LEAK TEST**  
PRESS <STEP> TO CONTINUE

### TO STOP SINGLE TANK TESTING

Press **Step**, **Change**, **Enter** and **Step**. The display will show:

**STOP LEAK TEST: TANK X**  
PRESS <ENTER>

For individual tanks, press **Tank** to select the desired tank.

Press **Enter** to halt the test. The system confirms the ending of the test by displaying:

**LEAK TEST NOT ACTIVE**  
PRESS <FUNCTION> TO CONT.

### TO STOP TESTING ALL TANKS

Press **Step** twice. The display will show:

**STOP LEAK TEST: ALL TANKS**  
PRESS <ENTER>

Press **Enter** to halt the test. The system confirms the ending of the test by displaying:

**LEAK TEST NOT ACTIVE**  
PRESS <FUNCTION> TO CONT.

## Pressurized Line Leak Detection Tests (PLLD Option)

### TO START A PLLD TEST

In the Operating mode, press **Function** until the display shows:

START LINE PRESSURE TEST  
PRESS <STEP> TO CONTINUE

Press **Step** and the display shows:

SELECT LINE  
ALL LINES

Press **Step** to accept all lines. To select a single line, press **Change** until you see the line you want, then press **Enter** and **Step**. The display below appears:

SELECT TEST TYPE  
3.0 GPH

This step lets you select 3.0, 0.2, or 0.1 gph line leak tests to run on the selected line(s). If your system does not have 0.2 or 0.1 gph test options, you will not see these selections.

To select 3.0 gph test, press **Step**, or press **Change** to select 0.2 or 0.1 gph tests, then press **Enter**.

To select the 3.0 gph test, press **Step**. The display shows:

3.0 GPH  
PRESS <STEP> TO CONTINUE

To run the selected test, press **Step**. The system displays the message (in this example for all lines):

START LINE TEST: ALL LINE  
PRESS <ENTER>

Press **Enter** to begin the test. The system displays:

Q#: RUNNING PUMP  
PRESS <STEP> TO CONTINUE

To exit this function, press **Step**.

## TO STOP A PLLD TEST

In the Operating mode, press **Function** until you see the message:

**STOP LINE PRESSURE TEST**  
PRESS <STEP> TO CONTINUE

Press **Step**. The system displays the message:

**SELECT LINE**  
ALL LINES

Press **Enter** to stop the test on all lines, or press **Change** and the system displays the message:

**STOP LINE TEST: LINE (#)**  
PRESS <ENTER>

Press **Enter** to stop the test on the line shown, or press **Change** until you see the line you want to select, then press **Enter**. The system stops the test and displays the status message:

**Q#: TEST ABORTED**  
PRESS <STEP> TO CONTINUE

## TO PRINT ALL PLLD TEST RESULTS

In the Operating mode, press **Function** until you see the display below then press **Print**:

**PRESSURE LINE RESULTS**  
PRESS <STEP> TO CONTINUE

## Wireless Pressurized Line Leak Detection Tests (WPLLD Option)

### TO START A WPLLD TEST

In the Operating mode, press **Function** until the display shows:

```
START LINE PRESSURE TEST
PRESS <STEP> TO CONTINUE
```

Press **Step** and the display shows:

```
SELECT LINE
ALL LINES
```

Press **Step** to accept all lines. To select a single line, press **Change** until you see the line you want, then press **Enter** and **Step**. The display below appears:

```
SELECT TEST TYPE
3.0 GPH
```

This step lets you select 3.0, 0.2, or 0.1 gph line leak tests to run on the selected line(s). If your system does not have 0.2 or 0.1 gph test options, you will not see these selections.

To select 3.0 gph test, press **Step**, or press **Change** to select 0.2 or 0.1 gph tests, then press **Enter**.

To select the 3.0 gph test, press **Step**. The display shows:

```
3.0 GPH
PRESS <STEP> TO CONTINUE
```

To run the selected test, press **Step**. The system displays the message (in this example for all lines):

```
START LINE TEST: ALL LINE
PRESS <ENTER>
```

Press **Enter** to begin the test. The system displays:

```
W#: TEST PENDING
PRESS <STEP> TO CONTINUE
```

To exit this function, press **Step**.



### TO STOP A WPLLD TEST

In the Operating mode, press **Function** until you see the message:

```
STOP WPLLD LINE TEST  
PRESS <STEP> TO CONTINUE
```

Press **Step**. The system displays the message:

```
SELECT LINE  
ALL LINES
```

Press **Enter** to stop the test on all lines, or press **Change** and the system displays the message:

```
STOP LINE TEST: LINE (#)  
PRESS <ENTER>
```

Press **Enter** to stop the test on the line shown, or press **Change** until you see the line you want to select, then press **Enter**. The system stops the test and displays the status message:

```
W#: TEST ABORTED  
PRESS <STEP> TO CONTINUE
```

### TO PRINT ALL WPLLD TEST RESULTS

In the Operating mode, press **Function** until you see the display below then press **Print**:

```
WPLLD LINE RESULTS  
PRESS <STEP> TO CONTINUE
```

## To Set The System Date

Press **Mode** until the display shows:

SETUP MODE  
PRESS <FUNCTION> TO CONT.

Press **Function**. If the system has a security passcode you will be asked to enter a six digit code:

SETUP MODE  
ENTER PASSCODE:

Enter the code using the alphanumeric keys and press **Enter**. The display will show:

SYSTEM SETUP  
PRESS <STEP> TO CONTINUE

Press **Step** 4 times to display the date:

SET MONTH DAY YEAR  
DATE: 04/20/2006

If the date is correct press **Step**, if not, press **Change** and enter the correct date. (Note that the month must be entered first.)

Press **Enter**, the new date will be displayed:

DATE: 06/29/2006  
PRESS <STEP> TO CONTINUE

## To Set The System Time

If the date is correct press **Step**.

The display will show:

```
SET TIME
TIME: 8:24 AM
```

If the time is correct press **Mode** twice to return to the Operating mode.

To change the time press **Change** and enter the correct time. Select either AM or PM by using the arrow keys.

Press **Enter** to confirm the time. The display will show:

```
TIME: 1:24 PM
PRESS <STEP> TO CONTINUE
```

If the time is correct press **Mode** to return to the Operating mode.

## Changing The Printer Paper

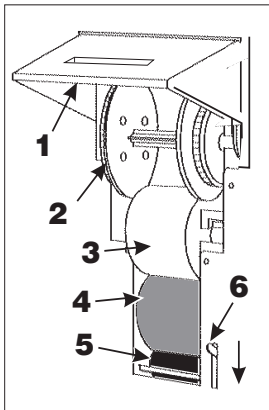

The paper roll should be changed when a red stripe appears on the printouts.

A 4-roll pack of printer paper (Part Number 514100-210) is available from your Service Contractor.

Swing up the printer cover (1) and push the paper feed release lever (6) down. Notice the paper roll (3) and paper feed guide (4).

If the take-up spool (2) has been used, pull out the spool with the printed reports and tear off the paper close to the printer feed roller(5).

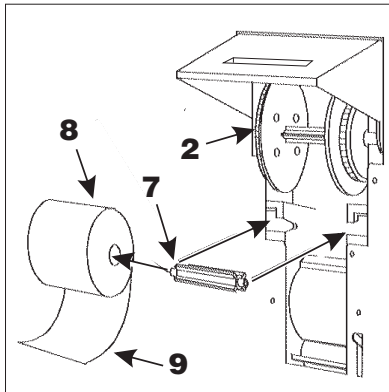

Pull out the take-up spool (2) and separate its two halves by pulling them apart. Remove the printed reports, but do not discard the reports as they may be required later.

Pull out the old paper roll (3) and any remaining paper.

Remove the roll shaft (7) and press it into the new roll (8).

Push the roll (8) into the lower slots in the printer with the paper tail (9) down and at the back.

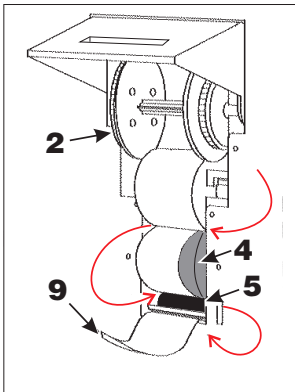

Feed the paper tail (9) over the paper guide (4) and down behind the the paper feed roller (5).

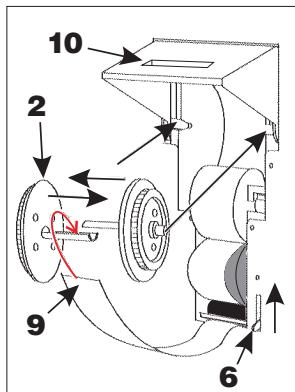

If using the Take-up Spool (2) place the paper tail (9) between the two halves and press them firmly together until you hear a click.

Push the Take-up Spool (2) into the upper slots. Rotate the spool counterclockwise until you remove all slack in the paper. (If the Take-up Spool is not going to be used, thread the paper tail through the slot (10) in the printer cover.)

Push the paper release lever (6) up and close the cover.



For technical support, sales or  
other assistance, please visit:  
[www.veeder.com](http://www.veeder.com)