

Installation Manual

Wireless Pressurized Line Leak Modules For Veeder-Root TLS-350/350R Systems

Manual Number 577013-481, Revision C

Communications Module

AC Interface Module

Controller Module

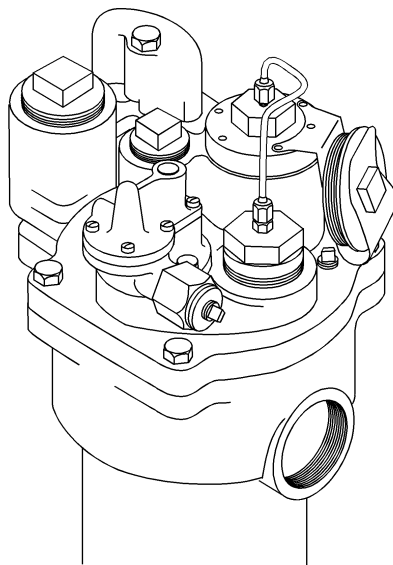
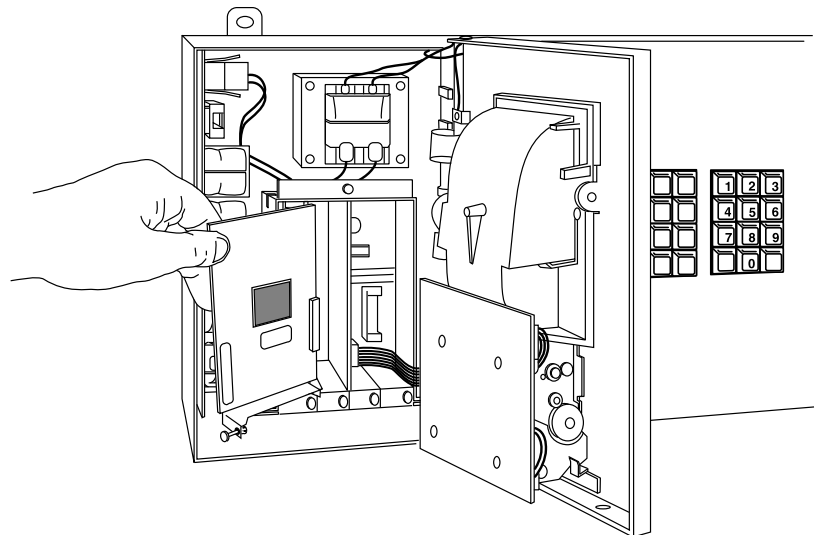

Notice

Veeder-Root makes no warranty of any kind with regard to this publication, including, but not limited to, the implied warranties of merchantability and fitness for a particular purpose.

Veeder-Root shall not be liable for errors contained herein or for incidental or consequential damages in connection with the furnishing, performance, or use of this publication.

This publication contains proprietary information which is protected by copyright. All rights reserved. No part of this publication may be photocopied, reproduced, or translated to another language without the prior written consent of Veeder-Root.

The information contained in this publication is subject to change without notice.

FCC Information

This equipment complies with the requirements in Part 15 of the FCC rules for a Class A computing device. Operation of this equipment in a residential area may cause unacceptable interference to radio and TV reception requiring the operator to take whatever steps are necessary to correct the interference.

Reader Comment Card

Please take a moment to review this manual. Your comments will help us improve our manuals. *Thank you!*

Please circle one number for each.	Strongly Agree	Agree	Neutral	Disagree	Strongly Disagree
This manual contains the information I need.	5	4	3	2	1
This manual is well organized.	5	4	3	2	1
Layout and format of the manual make it easy to use.	5	4	3	2	1
Instructions are easy to understand.	5	4	3	2	1
Instructions are complete.	5	4	3	2	1
Illustrations are clear and helpful.	5	4	3	2	1
There are enough illustrations.	5	4	3	2	1
Manual meets my expectations.	5	4	3	2	1
Things I would like to see added:					
Write additional comments. Please be specific.					

577013-339, Revision A



Manual Name	Manual Title
Your Name	Your Title
Company	
Address	
City/State/Zip	Phone



Mail to:
 Technical Publications Dept.
 Veeder-Root
 P.O. Box 2003
 Simsbury, CT 06070-2003
Or fax to:
 (860) 651-2719
 Attn: Technical Publications Dept.

Veeder-Root Support

Calling for Help

Please use these telephone numbers when you need help:

Customer Service	
Orders, accessories and supplies, customer support assistance, nearest authorized Veeder-Root distributor	 800-873-3313  800-234-5350
<i>Monday - Friday, 8 a.m. - 6 p.m. Eastern Standard Time</i>	

Product Information	
Literature requests Sales applications information Technical applications information	 800-873-3313  800-234-5350
<i>Monday - Friday, 8 a.m. - 4:30 p.m. Eastern Standard Time</i>	

Technical Support (for Authorized Contractors only)	
Technical Service	 860-651-2753
<i>Monday - Friday, 8 a.m. - 7 p.m. Eastern Standard Time</i>	

Contents

- Veeder-Root Support**
 - Calling for Helpi

- Introduction**
 - General1
 - Safety Symbols2
 - Safety Warnings2

- WPLLD Communications Module**
 - Requirements3
 - Communications Module Installation3

- AC Interface and WPLLD Controller Modules**
 - Requirements7
 - AC Interface and Controller Module Installation7
 - Module/Connector Positions8

- WPLLD Software Requirements**
 - System Requirements10
 - System Limitations10

- Warranty Conditions and Limitations of Liability**
 - Limitations Of Liability11
 - Inspection11
 - Limitation of Remedy and Warranty11
 - Limitation of Damages12
 - Limitation of Actions12
 - Collateral Promises12
 - Interpretation12

- Glossary**13

Figures

Figure 1.	CPU Board Battery Switch ON (S2).....	4
Figure 2.	ECPU Board Battery Switch ON (SW1).....	5
Figure 3.	Communications Module Installation	6
Figure 4.	Communications Interface Area	9
Figure 5.	AC Interface and Controller Modules.....	9

Introduction

General

This manual tells you how to install the Communications Module, AC Interface Module, and Controller Module for the Veeder-Root Wireless Pressurized Line Leak Detection (WPLLD) System. This system is used with FE Petro or Red Jacket Pumps in either a TLS-350 UST Monitoring System (Version 12 Software or later) or a TLS-350R Environmental & Inventory Management System (Version 112 or 312 Software, or later).

It is assumed that all preliminary site preparation is completed, and that field wiring is in place. If this is a new installation or if site preparation is necessary, refer to the Veeder-Root TLS-350 and TLS-350R *Site Preparation and Installation Manual* (576013-923), or contact your Veeder-Root representative for assistance.

Safety Symbols

The following safety symbols are used throughout this manual to alert you to important safety hazards and precautions



Electricity

High voltage exists in, and is supplied to, the device. A potential shock hazard exists.



Explosive

Fuels and their vapors are extremely explosive if ignited.



Flammable

Fuels and their vapors are extremely flammable.







Turn Power Off

Live power to a device creates a potential shock hazard. Always turn power off to the device and associated STPs when servicing unit.



Read all instructions and symbol warnings.

Safety Warnings

 WARNING	
  	<p>You are working with a device in which potentially lethal voltages may be present.</p> <p>Death or injury may result if safety precautions are not followed.</p> <ol style="list-style-type: none"> 1. Read all instructions and symbol warnings. 2. Turn power off before installing these modules.

WPLLD Communications Module

Requirements

Installing communications modules in a TLS-350 or TLS-350R console is a simple process. However, there are important points to remember:

1. For each module, a corresponding communications slot must be available.
2. ALL unused communications slots MUST be covered.

Important

Communications interface module expansion slots 1 and 2 (only) may be used for the TLS-350 with printer; slots 1, 2, or 3 may be used for the TLS-350 without printer; and slots 1, 2, or 3 may be used for the TLS-350R either with or without printer.

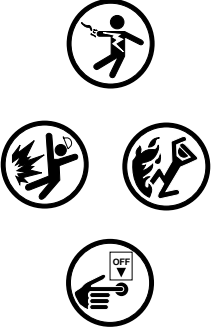
 WARNING	
	<p>You are working with a device in which potentially lethal voltages may be present.</p> <p>If high voltage is shorted across any barrier terminal, explosion and fire could result.</p> <p>Be sure AC POWER to the TLS-350 or TLS-350R is OFF before opening the front panel and installing or wiring any communications module.</p>

Communications Module Installation

For additional information regarding the below steps, refer to the Veeder-Root TLS-350 or TLS-350R *Site Preparation and Installation* manual.



1. Read and follow all instructions carefully.
2. Open the left-hand door of the TLS-350 or TLS350R console by unscrewing the left-top and left-bottom locking bolts.
3. To retain current programming, be sure that the CPU (for TLS-350) or ECPU (for TLS-350R) board battery switch is set to “ON”; see Figure 1 on page 4 and Figure 2 on page 5). To avoid electrical shock or damage to components, if accessing the battery switch, avoid touching any circuit components with your hand or any conductive tool or jewelry.

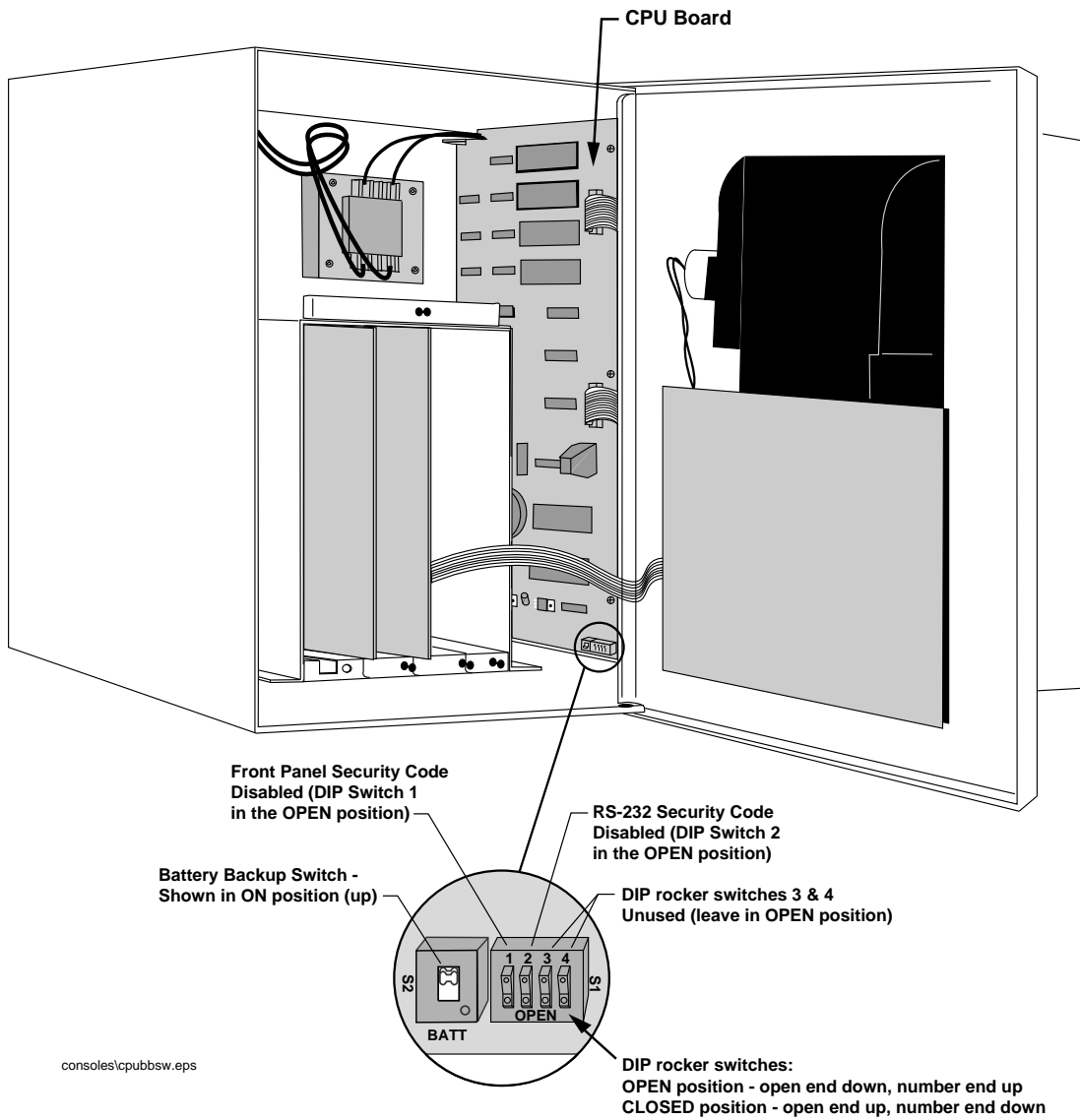

console\cpubb\sw.eps

Figure 1. CPU Board Battery Switch ON (S2)

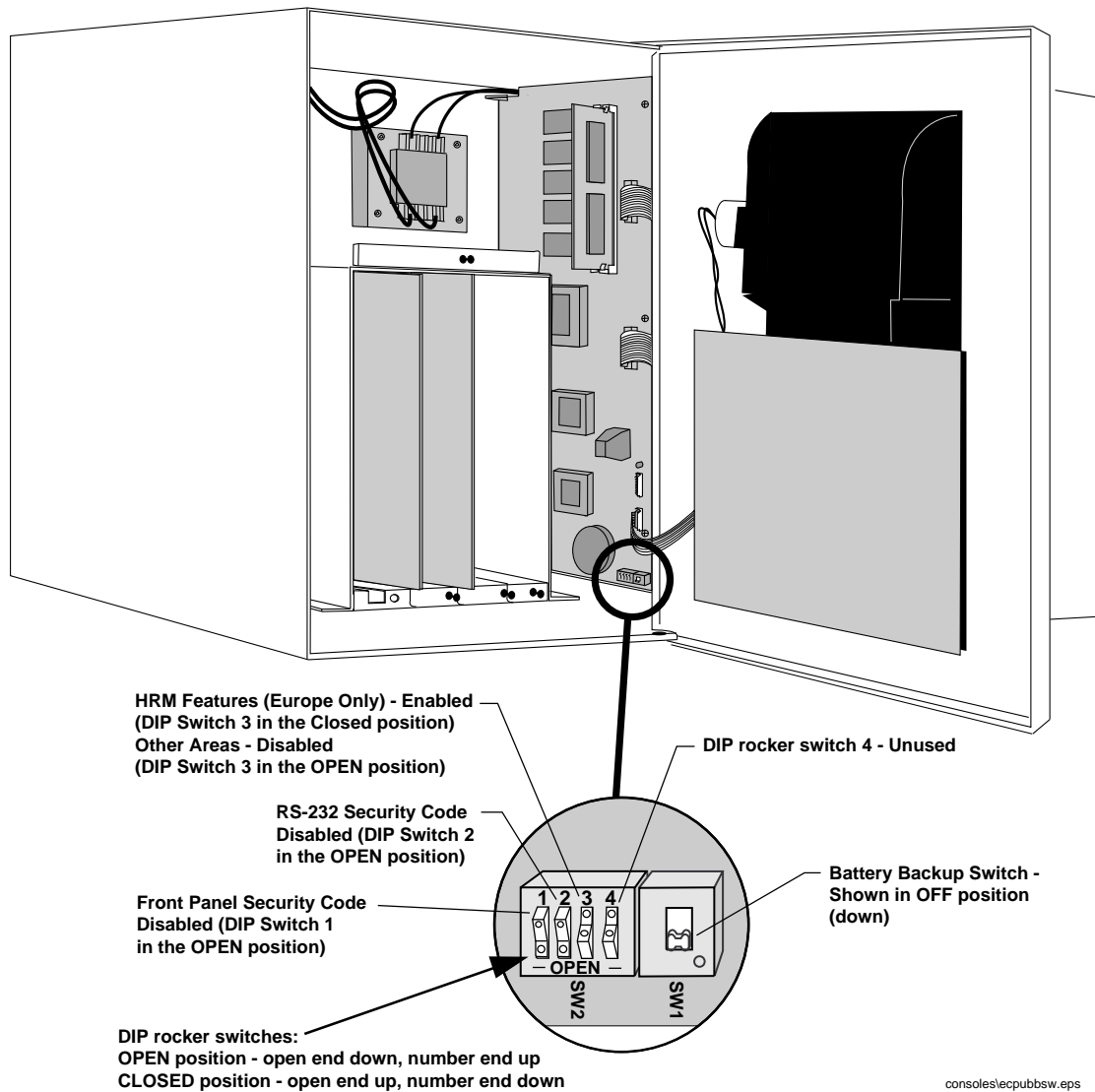

Figure 2. EPCU Board Battery Switch ON (SW1)



4. Turn console POWER OFF before installing the module.
5. Avoid shorting high voltage across any component or module to the intrinsically safe section of the console. This could result in an explosion near the device.
6. Remove the existing retaining bracket panel from the communication compartment.

Important ☞ *A maximum of three modules of any type can be used in the communication compartment. The WPLLD module is to be installed in only the communications interface area of the console.*

7. Hold the module with its snap-in fastener positioned at the lower edge and carefully slide the module into its slot (see Figure 3 on page 6 and Figure 4 on page 9).
8. To secure the module, press down on the snap-in fastener until its connector engages completely with the connector on the board. Do not apply excessive force when installing the module.
9. BE SURE ALL UNUSED SLOTS at the bottom of the communication compartment ARE COVERED with snap-in plates! (Veeder-Root Module Cover Part No. 329332-001.)

Important ☞ *If you are installing these modules in a system that has already been programmed, you CANNOT CHANGE the position of existing modules and/or connectors without reprogramming the entire system.*

If any connectors are removed during installation, BE SURE they are reconnected to their original modules.

The following shows placement of a Communications Module into an expansion slot (can only be installed in slots 1, 2, or 3):

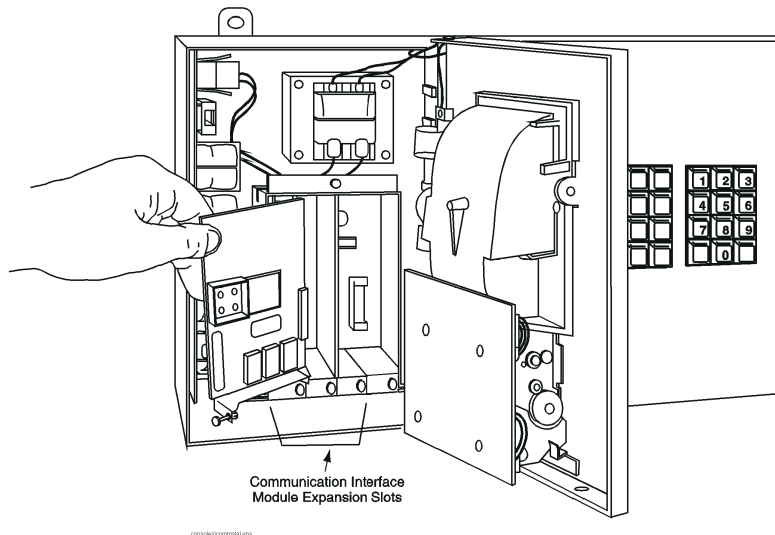



Figure 3. Communications Module Installation

AC Interface and WPLLD Controller Modules

Requirements

Installing interface modules in a TLS-350 or TLS-350R console is a simple process. However, there are important points to remember:

1. For each module, a corresponding expansion slot with a connector must be available.
2. ALL unused expansion slots MUST be covered.
3. A minimum of two empty high voltage slots are needed in the TLS-350 or TLS-350R.

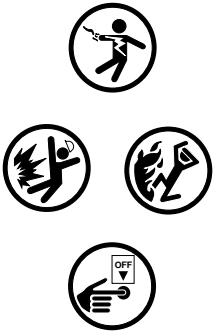
 WARNING	
	<p>You are working with a device in which potentially lethal voltages may be present.</p> <p>If high voltage is shorted across any barrier terminal, explosion and fire could result.</p> <p>Be sure AC POWER to the TLS-350 or TLS-350R monitor is OFF before opening the front panel and installing or wiring any communications module.</p>

AC Interface and Controller Module Installation

For additional information regarding the below steps, refer to the Veeder-Root TLS-350 or TLS-350R *Site Preparation and Installation* manual.



1. Read and follow all instructions carefully.
2. Open the right-hand door of the TLS-350 or TLS-350R console by unscrewing the right-top and right-bottom locking bolts.
3. To retain current programming, be sure that the CPU (for TLS-350) or ECPU (for TLS-350R) board battery switch is set to "ON" (see Figure 1 on page 4 and Figure 2 on page 5). To avoid electrical shock or damage to components, if accessing the battery switch, avoid touching any circuit components with your hand or any conductive tool or jewelry.
4. Turn console POWER OFF before installing the module.





5. Avoid shorting high voltage across any component or module to the intrinsically safe section of the console. This could result in an explosion near the sensor.
6. Remove two existing retaining bracket panels from the compartment.
7. Hold the first module with its snap-in fastener positioned at the lower edge, and carefully slide the module into its slot. Repeat for the second module.
8. To secure each module, press down on the snap-in fastener until its connector engages completely with the connector on the board. Do not apply excessive force when installing the module.
9. BE SURE ALL UNUSED SLOTS in the power area ARE COVERED with snap-in plates! (Veeder-Root Module Cover Part No. 329339-001.)
10. Connect the cable provided (Veeder-Root Part No. 330869-001) to the AC Interface Module (as shown in Figure 5 on page 9) and then to the WPLLD Communications Module (Figure 4 on page 9) by threading the cable over the partition between the communications area and the high voltage area (behind the doors).

Important  *If you are installing these modules in a system that has already been programmed, you CANNOT CHANGE the position of existing modules and/or connectors without reprogramming the entire system.*

If any connectors are removed during installation, BE SURE they are reconnected to their original modules.

Module/Connector Positions

Module Position

- Record on the circuit directory (on the inside front panel) the type of module you are installing in this slot.
- Once a particular type of module has been installed in that slot, the system will always look for that type of module in that slot.

Connector Position

- Identify all connectors according to their slot location using the self-adhesive numbering labels supplied with each module.
- Once a device has been wired to certain terminals on the connector and the system has been programmed, terminal position may not be changed without reprogramming the system.

The following shows AC Interface and WPLLD Controller Modules in a TLS Console:

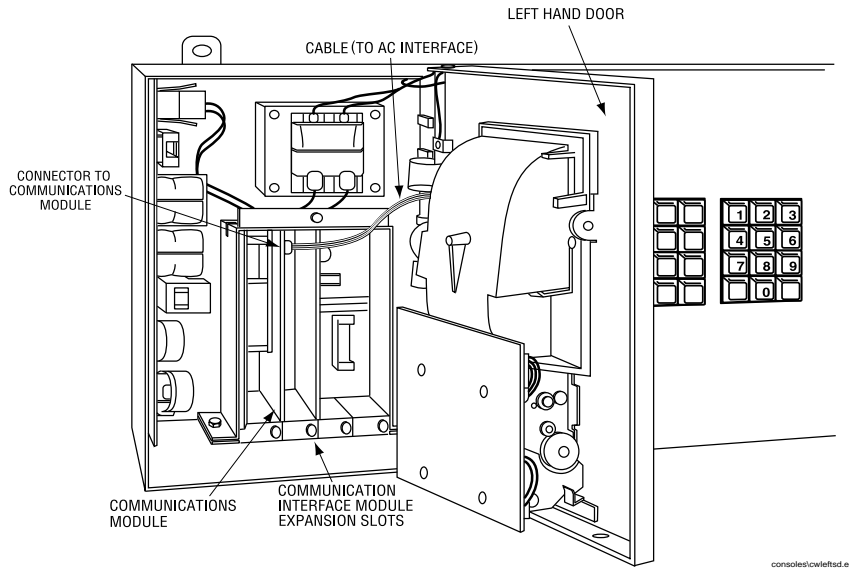

Figure 4. Communications Interface Area

The following shows AC Interface and WPLLD Controller Modules in a TLS Console:

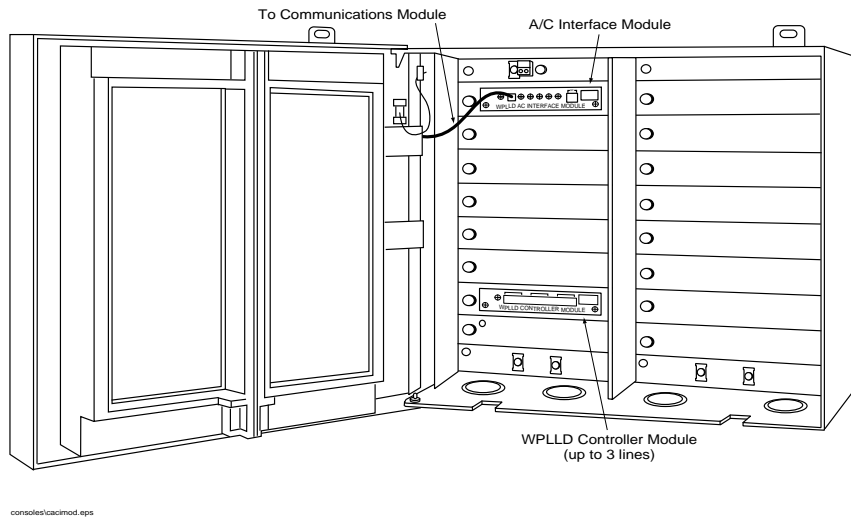

Figure 5. AC Interface and Controller Modules

WPLLD Software Requirements

System Requirements

Table 1. Software Version for TLS-350/TLS-350R Consoles

Software Version	Part Number
12 (or higher)	346012-XXX
112 (or higher)	346112-XXX
312 (or higher)	346312-XXX

Table 2. Software Key Module for Precision 0.1 GPH Tests

Consoles	Part Number
TLS-350	330160-010
TLS-350R	330160-110

Table 3. Software Key Module for Precision 0.2 GPH Tests

Consoles	Part Number
TLS-350	330160-050
TLS-350R	330160-150

Important  *You may need to order Module Expansion Board (Model No. 847490-001) if the console was originally shipped with less than two module installation slots in the High Power or Low Power Compartment.*

System Limitations

- Maximum of 12 lines.
- TLS-350 can only handle three Communications Modules (including the Printer Interface Module and WPLLD Communications Module).

Warranty Conditions and Limitations of Liability

Limitations Of Liability

We warrant that this product will be free from defects in materials and workmanship for a period of 1 year from the date of installation or 15 months from the date of invoice, whichever occurs first. We will repair or replace the product if it is returned to us, transportation prepaid, within the warranty period and is determined by us to be defective.

We shall not be responsible for any expenses incurred by the user.

This warranty applies only when the product is installed in accordance with Veeder-Root's specifications. This warranty will not apply to any product which has been subjected to misuse, negligence or accident; or misapplied; or used in violation of product manuals, instructions or warnings; or modified or repaired by unauthorized persons; or improperly installed.

Inspection

You shall inspect the product promptly after receipt and shall notify us at our Simsbury office in writing of any claims, including claims of breach of warranty, within 30 days after you discover or should have discovered the facts upon which the claim is based. Your failure to give written notice of a claim within the time period shall be deemed to be a waiver of such claim.

Limitation of Remedy and Warranty

The provisions of "Limitations Of Liability" on page 11 are our sole obligation and exclude all other remedies or warranties, express or implied, including warranties of MERCHANTABILITY and FITNESS FOR A PARTICULAR PURPOSE, whether or not purposes or specifications are described herein. We further disclaim any responsibility whatsoever to you or to any other person for injury to person or damage to or loss of property or value caused by any product which has been subjected to misuse, negligence, or accident; or misapplied; or used in violation of product manuals, instructions or warnings; or modified or repaired by unauthorized persons; or improperly installed.

Limitation of Damages

Under no circumstances shall we be liable for any incidental, consequential or specific damages, losses or expenses arising from this contract or its performance or in connection with the use of, or inability to use, our product for any purpose whatsoever.

Limitation of Actions

No action regardless of form arising out of this contract may be commenced more than 1 year after the cause of action has accrued, except an action for nonpayment.

Collateral Promises

There are no representations, warranties, or conditions, express or implied, statutory or otherwise except those herein contained, and no agreement or waivers collateral hereto shall be binding on either party unless in writing and signed by you and accepted by us at our Simsbury office.

Interpretation

Rights and liabilities arising out of any contract with us shall be determined under the Uniform Commercial Code as enacted in Connecticut.

Glossary

ASC	Authorized Service Contractor
AST	Aboveground Storage Tank
auxiliary port	Second serial port used for daisy chaining another console.
baud rate	Transmission speed for serial communications.
Business Inventory Reconciliation (BIR)	The process of reconciling product dispensed with product received (deliveries), and product remaining in the tank.
Current Loop Dispenser Interface Module (CDIM)	Installs in a communication port of EMC with BIR. More than one CDIM can be installed. May be installed with any combination of other DIM types. CDIM has three 4-pin phone jack connectors and three green LEDs inside, under cover. The green LEDs indicate data transmitted to DIM from an external device. CDIM cannot transmit to an external device. Connects via 4-wire cable to Adapter Box. Adapter box converts target communication format to RS-422 format for CDIM. Adapter boxes are configured with two-wire flying leads, 25-pin "D" or nine-pin "D" T-cable connectors for various applications.
coefficient of thermal expansion	The amount of contraction or expansion that will occur with temperature changes in a specific liquid.
communications	Data transmissions between two or more pieces of equipment.
configuration	Relative arrangement of parts of a system.
containment sump	An enclosure used to contain submersible pumps and related piping to prevent the release of product into the environment.
Continuous Statistical Leak Detection (CSLD)	CSLD eliminates the need to shut down the station to run leak tests. Height data is collected during idle times and new tank information is used to produce highly accurate leak detection results.
data	Information collected by the console.
default parameter setting	System set-up parameter that is pre-set by the factory.
diagnostics	Indicators of the current conditions in the system.
differentiating	See discriminating.
discriminating	Also referred to as differentiating. A sensor that provides different alarms in the presence of hydrocarbon (fuel) leaks compared with water or other liquids.
dispenser	Dispenses fuel through a nozzle, typically to a motor vehicle.
dispenser pan	An enclosure used to contain dispenser piping to prevent release of product into the environment.
double wall tank (DW tank)	A tank with a secondary wall to prevent leakage of product into the environment.

Electronic Dispenser Interface Module (EDIM)	Installs in a communication port of EMC with BIR. More than one EDIM can be installed. May be installed with any combination of other DIM types. EDIM has one 25-pin “D” connector outside of the port and a red and green LED inside, under cover: Red - DIM transmits to external device; Green - external device transmits to DIM.
external output	Field wiring locations where devices can be connected to the system, such as overflow alarms and warning lights.
float switch	A sensing device in which a float is used to indicate the presence of liquid.
groundwater	Water within the earth that supplies wells and springs.
hydrostatic sensor	A sensor used to monitor liquid-filled double walled tanks, such as brine-filled tanks.
inventory	How much product you have left.
interstitial	Relates to the interstice, a space or gap between the walls of a double wall tank. Also referred to as annulus.
intrinsically safe	A circuit in which any spark or thermal effect is incapable of causing ignition of combustible material.
magnetostriction	The deformation of any substance due to the existence of magnetism.
Mechanical Dispenser Interface Module (MDIM)	Installs in the power side of EMC with BIR. As many as eight MDIMs can be installed. MDIM has external eight-pin rectangular connector. May be installed with any combination of other DIM types. Connects to a maximum of four pulsers via intrinsically safe barriers which are mounted in any unused 1/2” or 1/4” hub of the dispenser junction box. Each barrier connects to a pulser with two wires that can be run anywhere inside the dispenser, without the need for conduit, because of the intrinsic safety provided by the barrier.
module	An electronic component that plugs into the console to perform a special function.
probe	A device used to obtain specific information in the tank and send the data to the console.
sensor	A device that responds to a physical stimulus (such as water or gasoline).
tri-state sensors	Tri-state sensors are piping sump sensors and steel and fiberglass tank interstitial sensors. The three conditions of this sensor are normal, fuel alarm, or sensor out.
Ullage	Amount of empty space in tank
95% Ullage	Amount of fuel required to fill tank to 95% capacity.
UST	Underground Storage Tank
vapor	A substance in the gaseous state as opposed to a liquid.
volumetric	A method of detecting leaks in pressurized piping.

Sales Offices

Veeder-Root has offices around the world to serve you.

Headquarters

Veeder-Root Company
125 Powder Forest Drive
Simsbury, CT 06070-2003 U.S.A.
860-651-2700 FAX: (860) 651-2719 TECH SUPPORT (860) 651-2753

England

Veeder-Root Environmental Systems Limited
Hydrex House, Garden Road
Richmond, Surrey TW9 4NR ENGLAND
44-181-392-1355

Brazil

Veeder-Root do BRASIL
Rua ado Benatti, 92
Caixa Postal 8343
01051 Sao Paulo BRAZIL
55-11-861-2155

Germany

Veeder-Root GmbH
Uhlandstrasse 49
D-78554 Aldingen GERMANY
49 (0)7424 89285

France

Veeder-Root SARL
ZI des Mardelles
94-106 rue Blaise Pascal
93600 Aulnay-sous-Bois FRANCE
33 (0)1 4879 5599

Canada

Veeder-Root Canada
151 Superior Boulevard, Suite 24
Mississauga, Ontario, L5T 2L1 CANADA
905-670-2755

Singapore

Veeder-Root Singapore
#2 Kallang Pudding Road
#06-16 Mactech Industrial Building
SINGAPORE 1334
(65) 745-0368 FAX: (65) 745-0636

Mexico

Veeder-Root Mexico
Prado de las Camelias
No. 4483-4
Praddos Tepeyac C.P. 45500
Zapopan, Jal., MEXICO
(52) 36-47-3750